



FISHERIES RESEARCH INSTITUTE - FRI

Dr. Manos Koutrakis

Research Director

Fisheries Research Institute (FRI),
Hellenic Agricultural Organization (ELGO DEMETER)

Nea Peramos, KAVALA,

www.inale.gr

Fisheries Research Institute - FRI

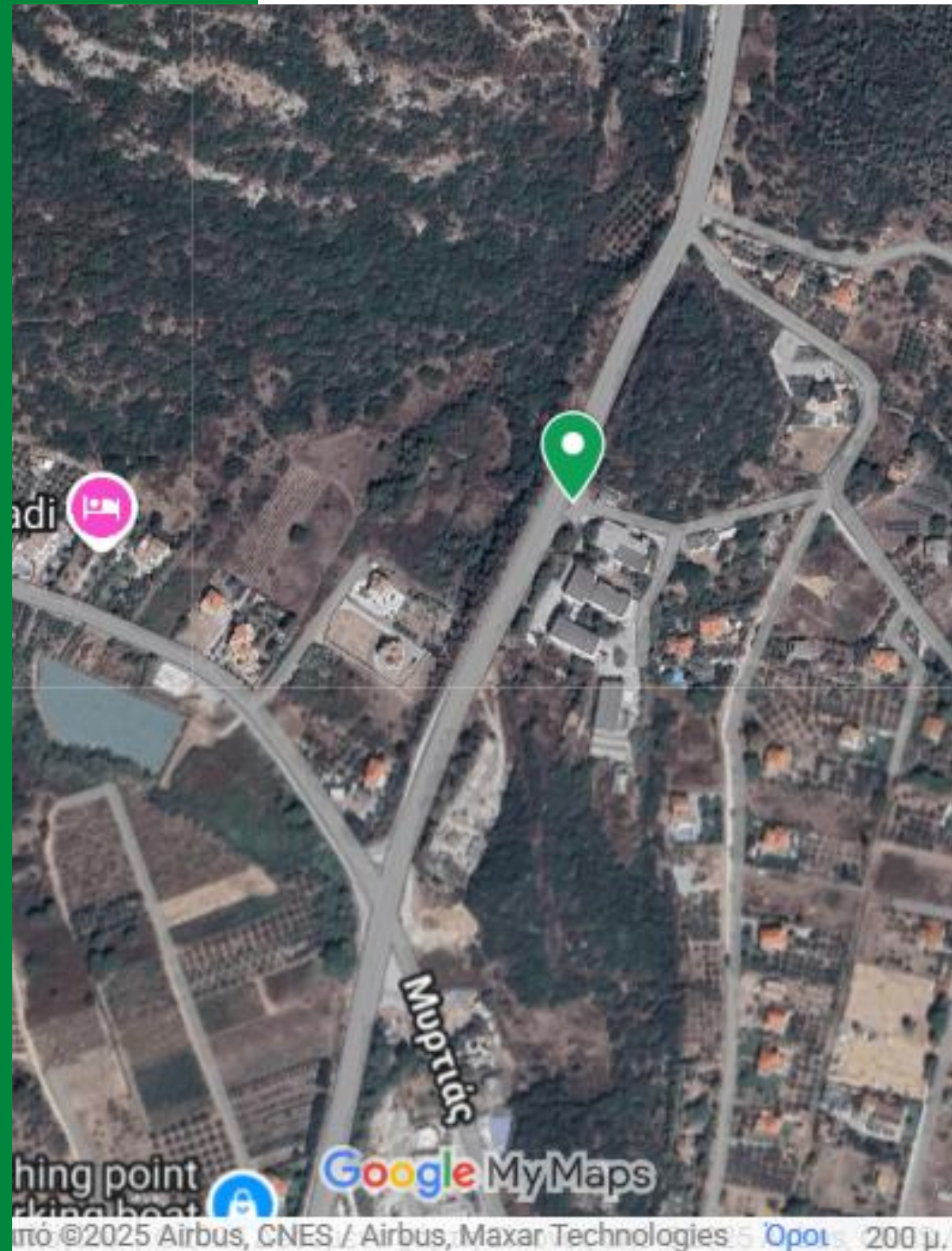

- Belongs to the Hellenic Agricultural Organization DIMITRA (ELGO – DIMITRA), which is supervised by the **Ministry of Rural Development and Food**
- Operates since 1995
- Located in Nea Peramos, Kavala

Contact:

Tel.: 25940 22691-2

Fax: 25940 22222

e-mail: fri@inale.gr

1. Department of Marine Biology

a. Fisheries Research Sector

1. Laboratory of Fisheries Biology
2. Laboratory of Stock Assessment
3. Laboratory of Oceanography

b. Utilization of Fisheries and Aquaculture Products Sector

1. Laboratory of Molecular Biology – Biotechnology
2. Laboratory of Fishery Products Processing

2. Department of Inland Waters & Lagoons

a. Fisheries Management Sector

1. Laboratory of Inland Water Fish Fauna
2. Laboratory of Environmental Monitoring

b. Environmental Management Sector

1. Laboratory of Benthic Ecology & Technology
2. Laboratory of Water Pollution

3. Department of Aquacultures of Inland and Marine Waters & Shellfish

1. Laboratory of Aquacultures (algae, fish & shellfish)
2. Laboratory of nutrition of marine organisms

Department – Sector – Laboratories (II)

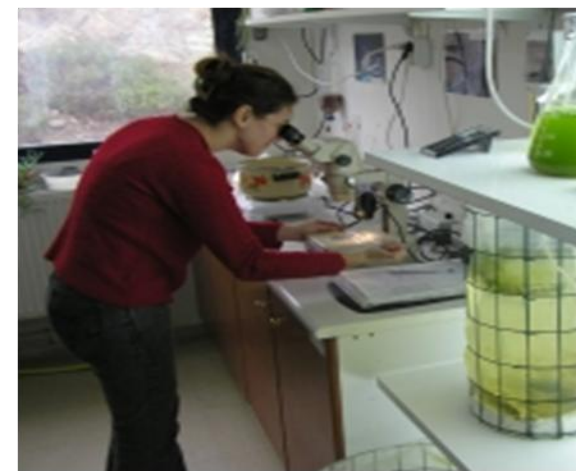
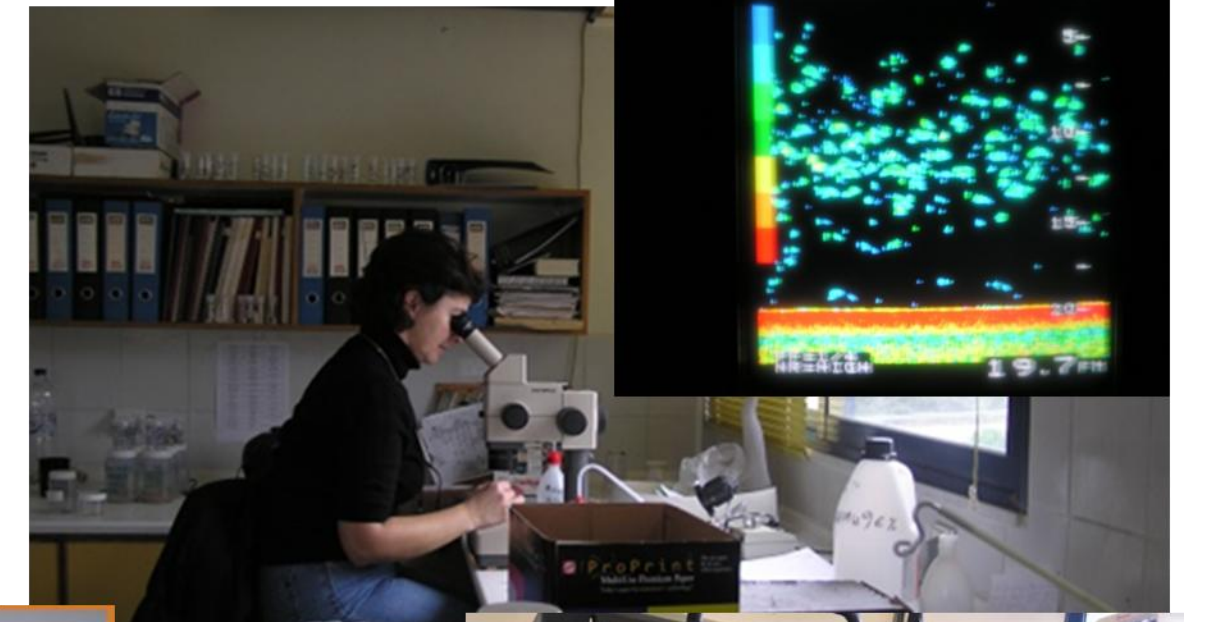
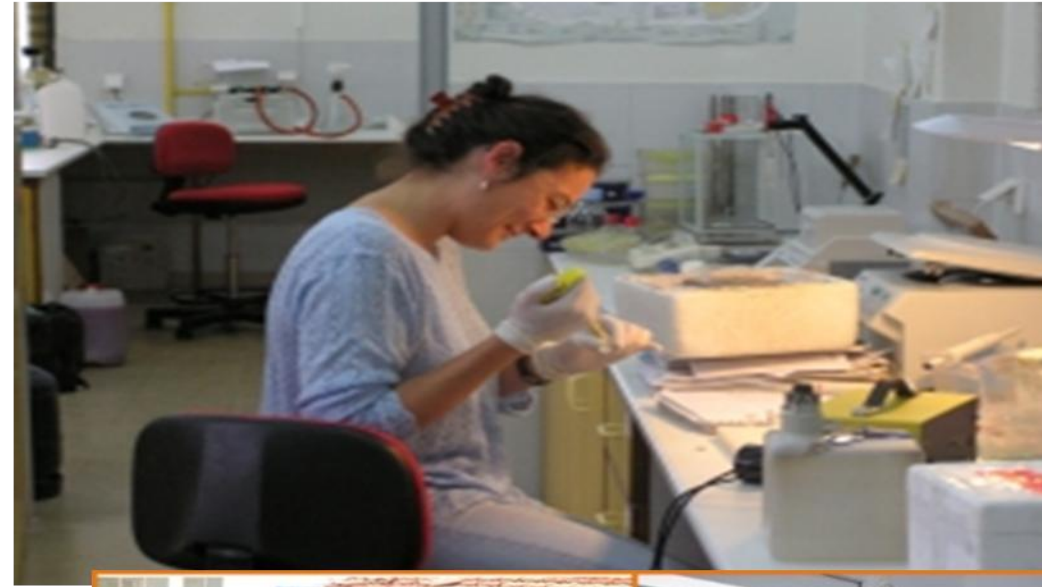

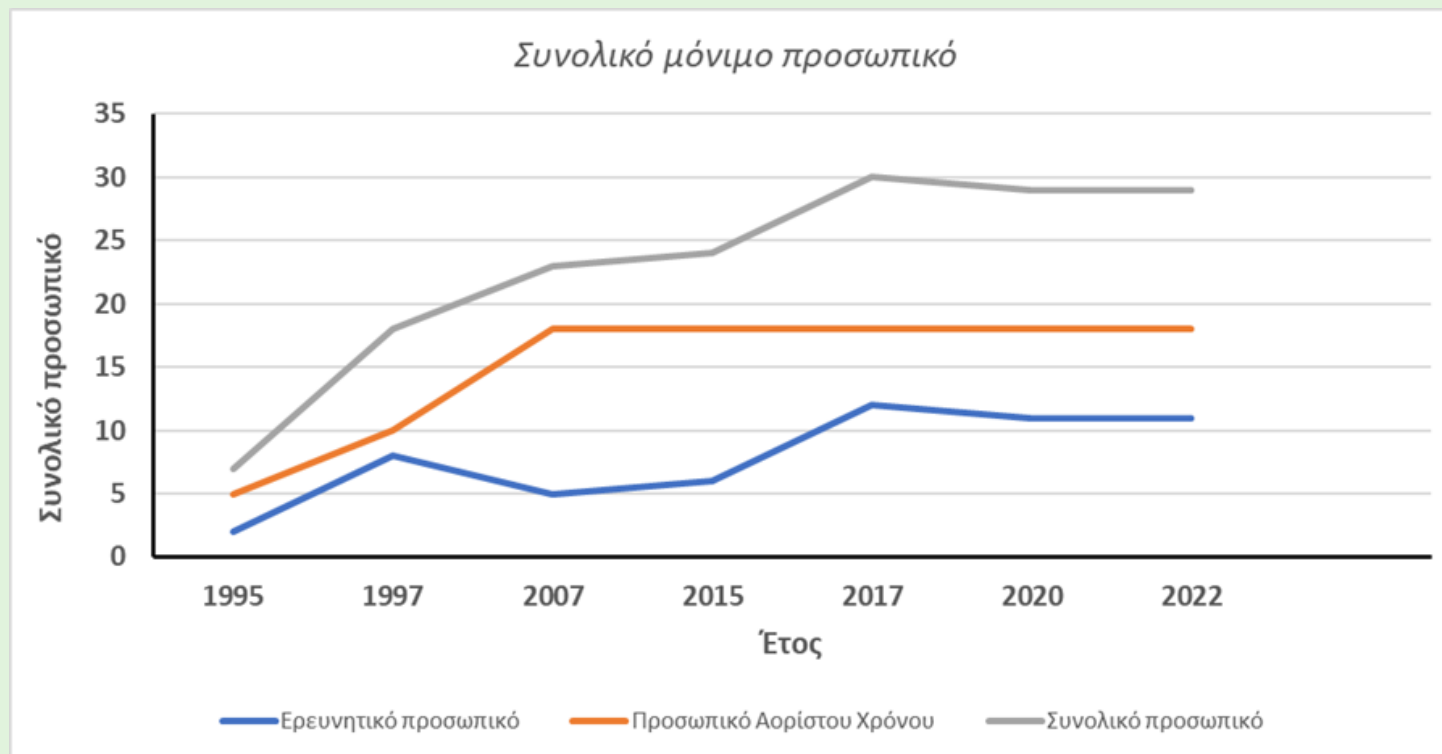

Human resources

- ✓ Research staff: 11 (2025)
- ✓ Permanent Staff: 18 (2025)
 - 10 Laboratory Technicians
 - 4 Administrative
 - 4 Technicians/Maintainers
- Scientific collaborators:
 - >60 (2020)

Research :

>70 Research Programs & Studies

Diving team:

- Founded in 2000
- 12 divers (advanced open water divers, rescue divers etc.)
- Participate in:
 1. research diving
 2. "beach cleaning" actions

Training:

>200 students & scientists were trained and are still being trained

FRI - Fields of Research and Interactions

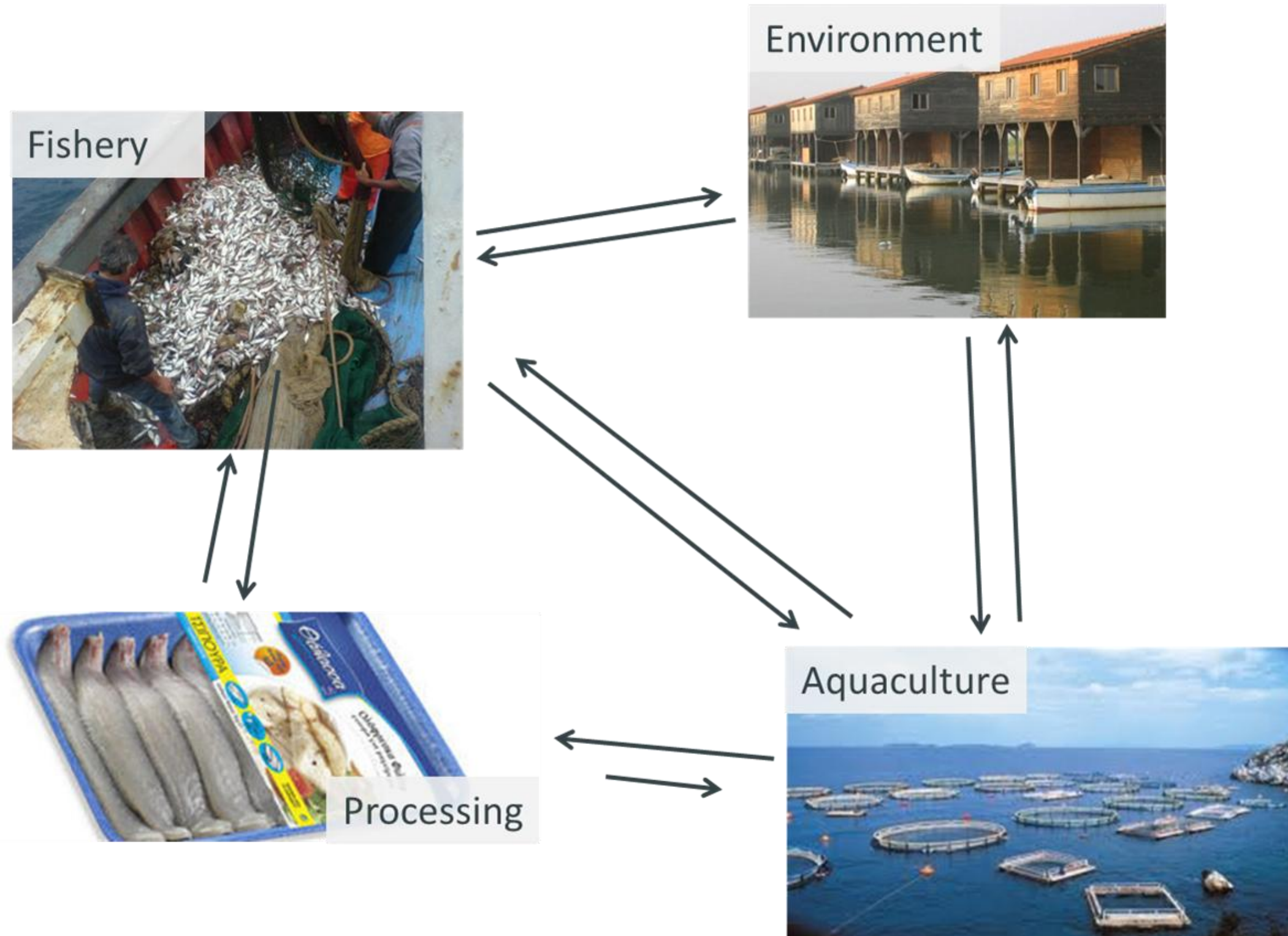

NATIONAL DATA COLLECTION FRAMEWORK, DCF

(2008/199, 2010/93, 2016/1251 EK) (I)

- It is an obligation of every EU Member State to provide scientific evidence to support the choices of the Common Fisheries Policy (CFP)
- Funded:
 1. 2001-2003: from the Community and national budgets
 2. 2003: Ministry of Rural Development & Food (project contractor) & EPALTH
 3. 2014-2020 - EU DG MARE 2014-2023: the resources come from the EAFRD 2014-2020 in which the Program has been included by the Decision No. 1617/09.12.2016
- Implemented by:
 1. Fisheries Research Institute (FRI) Hellenic Agricultural Organization – DEMETER (Coordinator)
 2. Agriculture Economics Research Institute (AGRERI) Hellenic Agricultural Organization – DEMETER
 3. Hellenic Centre for Marine Research (HCMR)

Trawling Fisheries



Purse-seine Fisheries



Coastal Small-scale Fisheries



NATIONAL DATA COLLECTION FRAMEWORK, DCF (2008/199, 2010/93, 2016/1251 EK) (II)

Aim of the project:

- Gathering the data needed to assess the status of fish stocks, the efficiency of the different parts of the fisheries sector, the impact of fisheries and aquaculture on the ecosystem.
- Establishment of multi-annual data sets, compatible between Member States, which will ensure the assessment of the state of fisheries resources and provide the basis for scientific advice to be used for decision-making on the Common Fisheries Policy.

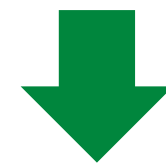

Fulfilling Greece's other obligations to the EU (annual fleet report, management plans, etc.) and to international organisations (GFCM, ICCAT, etc.).

FRI Staff:

In DCF through ΕΛΓΟ ΔΗΜΗΤΡΑ (FRI & INAGROK), collaborate 69 scientist:

- 43 scientific collaborators
- 15 partner from FRI's permanent staff
- 11 researchers

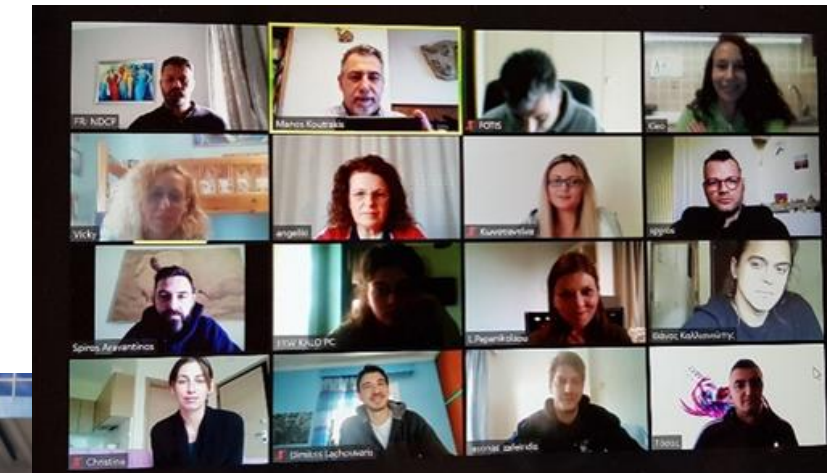

NATIONAL DATA COLLECTION FRAMEWORK, DCF (2008/199, 2010/93, 2016/1251 EK) (III)

DCF actions:

✓ Biological Data:

1. Commercial fisheries: collection of biological parameters, fishing effort and landings of catches [FRI-HCMR]
2. Data collection for recreational fisheries [FRI-HCMR]
3. Impact of fisheries on marine biological resources (PET species) [FRI-HCMR]
4. Diadromous species data collection in freshwater [FRI]
5. Research surveys at sea [FRI-HCMR]

✓ Socio-economic data:

1. Economic and social variables for fisheries data collection [AGRERI]
2. Economic and social variables for aquaculture and fish processing data collection [FRI]

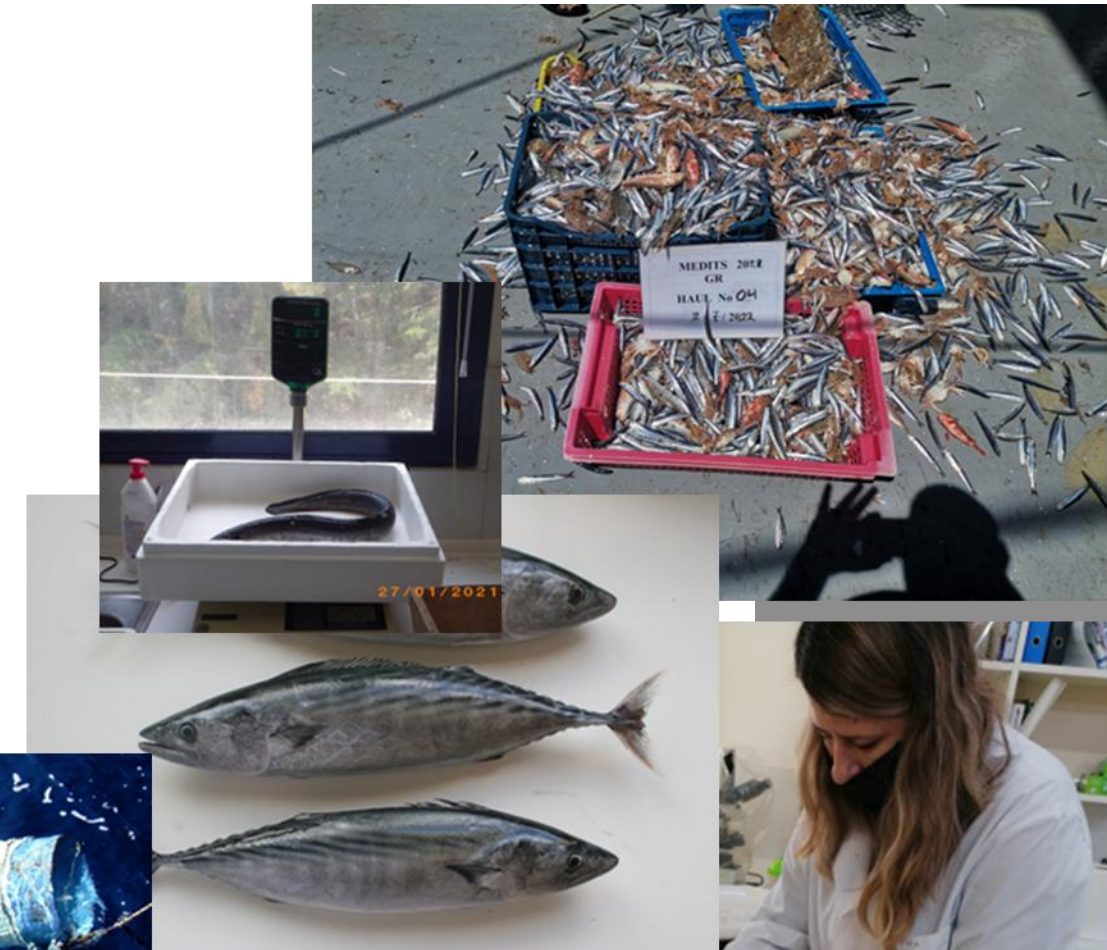
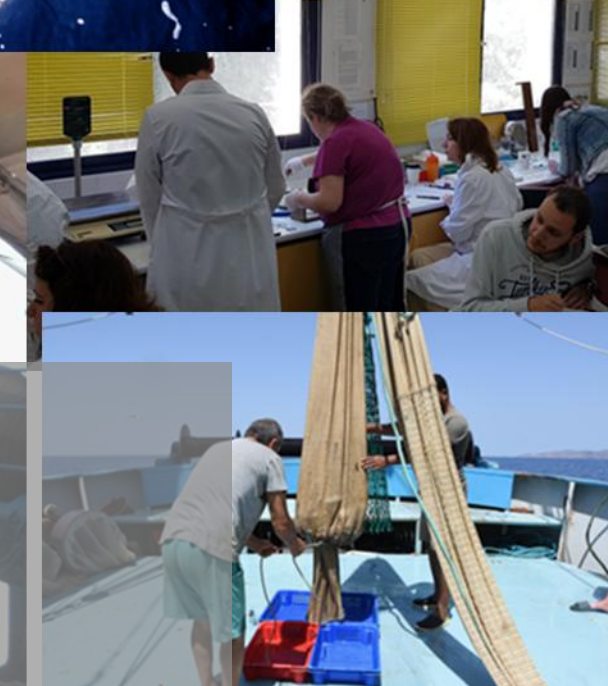
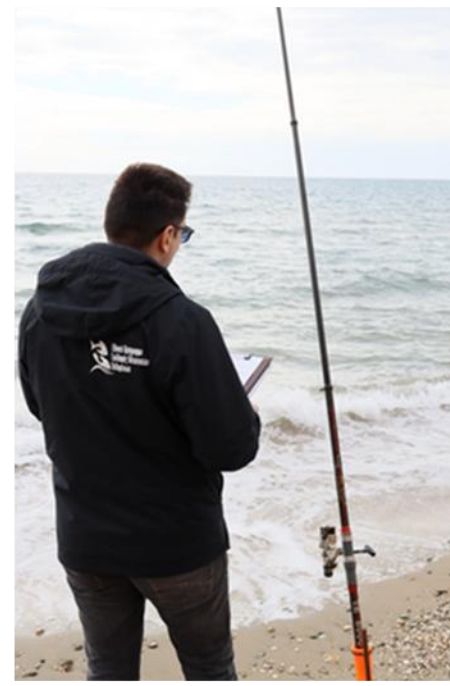

Biological Data (I)

Commercial fisheries: collection of biological parameters, fishing effort and landings of catches

Monitoring:

- ✓ Commercial fishing
- ✓ Recreational fishing

Contribution:

- ✓ In fisheries management
- ✓ In scientific documentation

Collection of data on biological variables:

- ✓ 3 geographic areas - GSA (Aegean, Ionian, Cretan)
- ✓ Monthly catch samples
- ✓ In **total 4,900 individuals**
- ✓ Samples from 34 species
- ✓ **Variables:** length, weight, sex, reproductive stage, age
- ✓ **Purpose:** determination of the length and weight composition
- ✓ **Use:** stock assessment

Collection of:

1. Data on Fishing Production & Fishing Effort
2. Biological data
3. Data on Social and economic data of fleet, aquaculture and manufacturing industry
4. Data on effects of Fishing on the natural environment



Biological Data (II)

Data collection for recreational fisheries

2017-2019 & 2020-21:

The objectives of the pilot study are:

- ✓ Estimation of the number of recreational fishermen in Greece
- ✓ Monitor of the activity of recreational fishermen
- ✓ Collection of detailed data on their catches

1st phase Telephone survey

The survey was carried out by a polling company based on a specific questionnaire, from which the average number of fishermen in each household, demographic data and fishing activity data were determined.

2st phase Logbook survey

Monthly report of their logbook data regarding the fishing location, fishing gear, catch (species, number, weight), catch retention or release.

3st phase On site Sampling survey

Three region in Greece (E. Macedonia, N. Greece, Argosaronic Gulf)

Activities: boat fishing, shore fishing, spearfishing

Catches: species, numbers and weight



Recreational fishermen participation rate by fishing gear and relevant overlapping subgroups

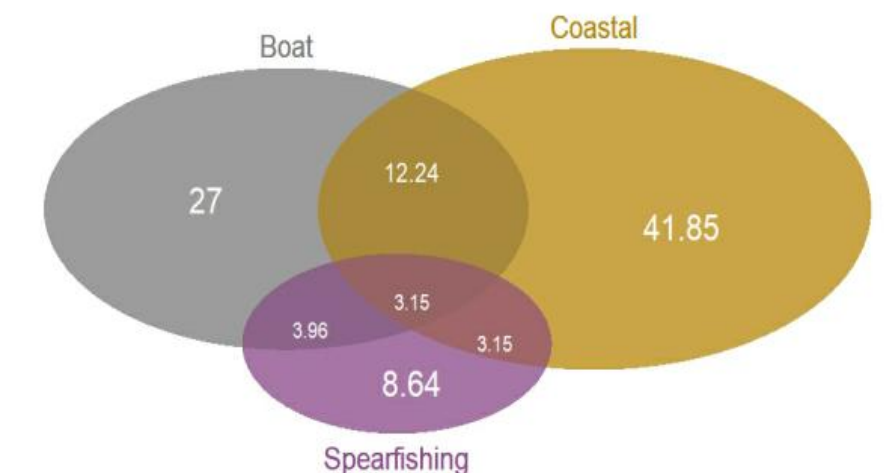

Estimated recreational catch compared to the catch of the commercial fisheries

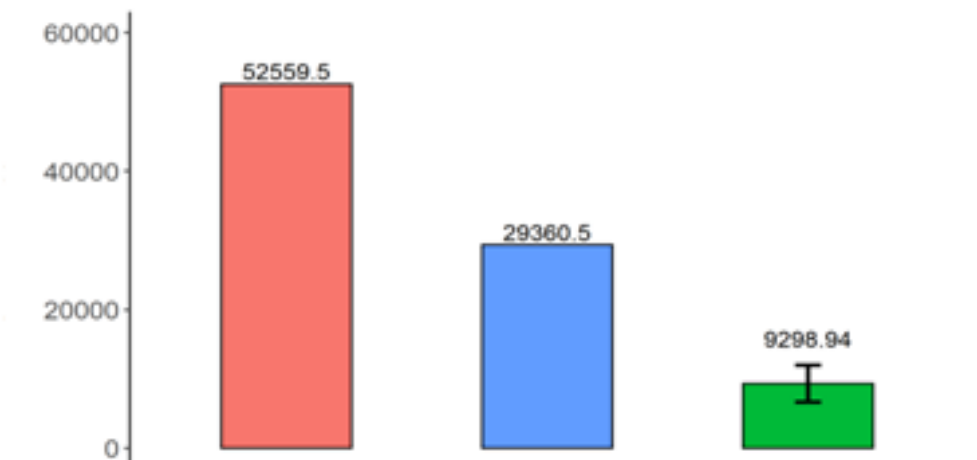

Biological Data (III)

Diadromous species data collection in freshwater

European eel (*Anguilla anguilla*):

- ✓ It is widely spread throughout Europe
- ✓ It is widespread & catadromous species
- ✓ It has an unusual & complex life cycle
- ✓ It breeds in the Sargasso Sea
- ✓ Its trade is subject to CITES regulations
- ✓ It is characterized as:
 1. "Near Threatened", Red Book of Endangered Vertebrates of Greece
 2. "Critically Endangered", IUCN Red List of Threatened Species

✓ Stock status:

1. Vertical decline
2. It is estimated that only 7% of the original population exists today

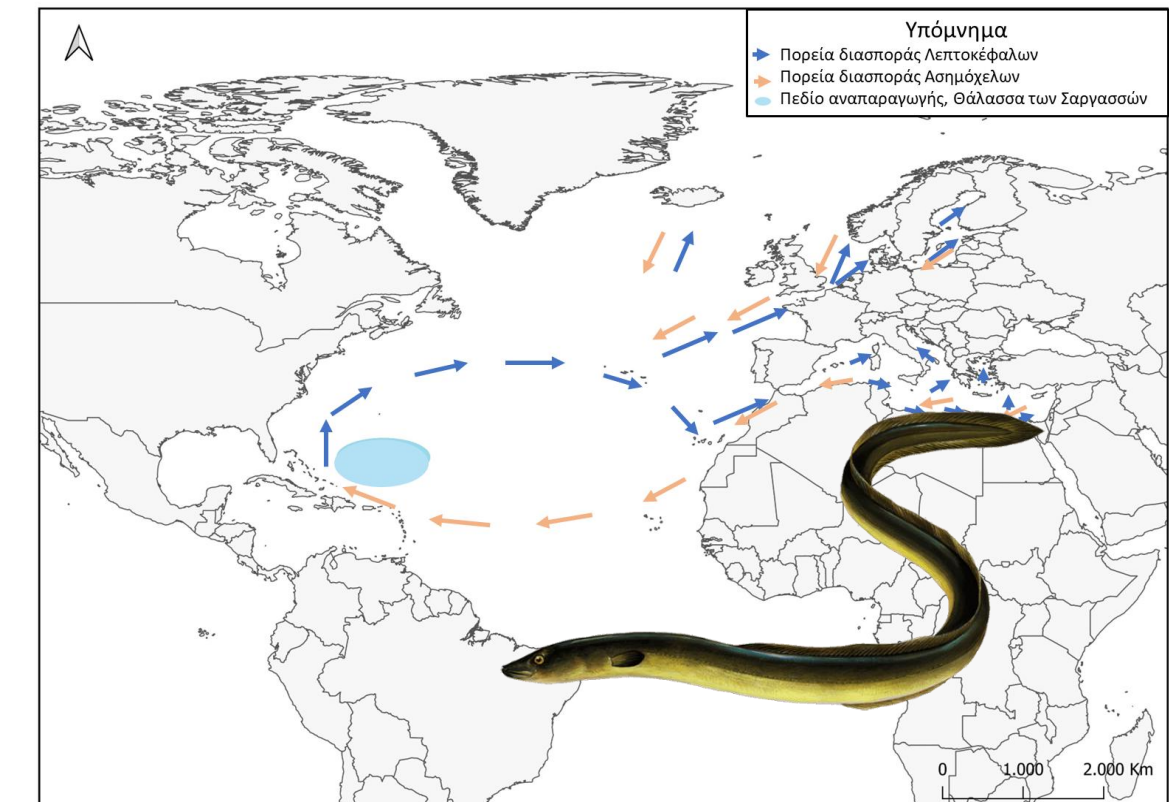

Biological Data (IV)

Research surveys at sea

International bottom trawl survey in the Mediterranean (MEDITS):

Annual survey:

- ✓ Started in 1995 and joined EPSAD in 2002
- ✓ All Mediterranean countries, members of the EU
- ✓ Common sampling protocol
- ✓ International coordination

Greece:

- ✓ 3 geographic sub-regions
- ✓ 5 depth zones 185 stations
- ✓ FRI: North Aegean 70 stations ~40 days (June-July)
- ✓ MEDITS Cyprus since 2012

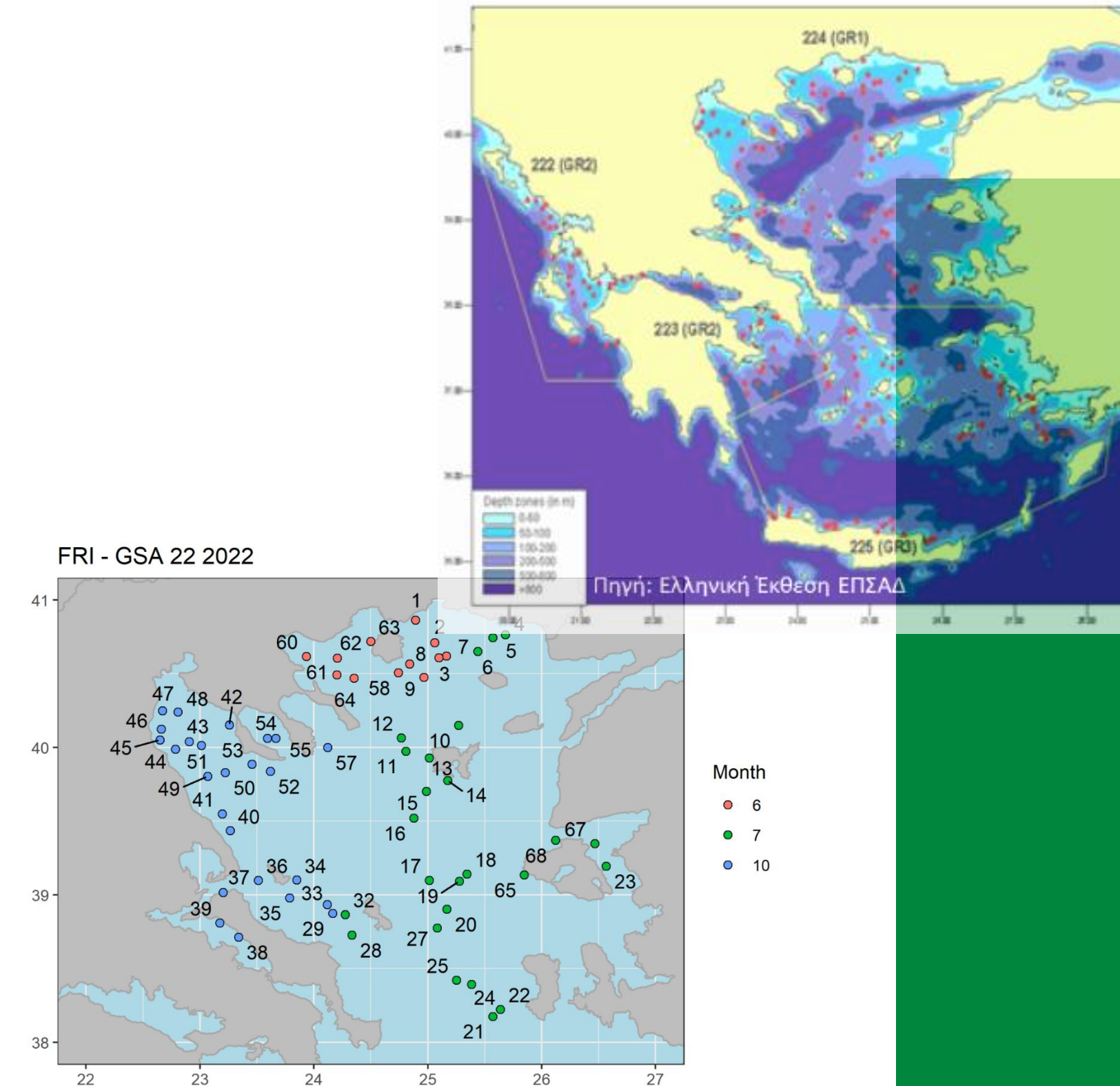

Marine Strategy Framework Directive (2008/56/EC, 2017-23)

"Sustainable management of natural resources as a socio-ecological tool"

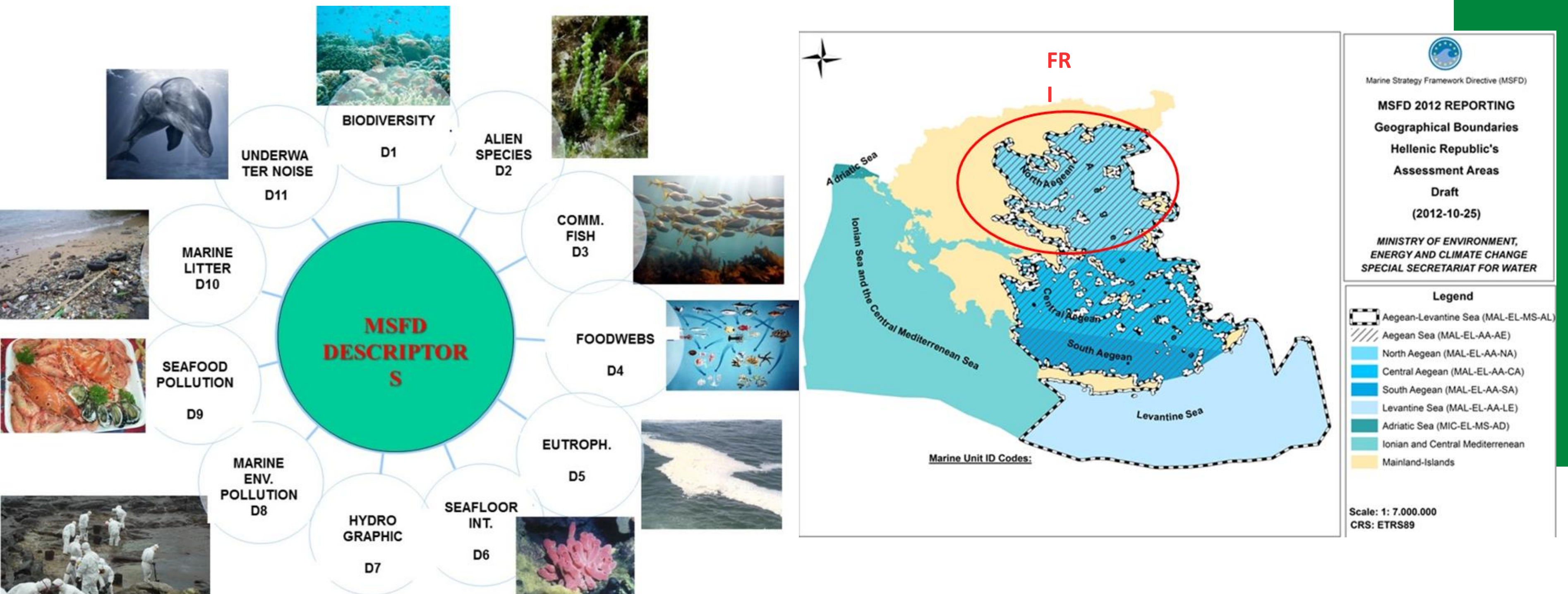

Fisheries Management of Inland Waters and Lagoons (I)

- ✓ DCF:
 - «Data Collection of Anadromous and Catadromous Inland Species»
- ✓ Framework Directive 2000/60/EC:
 - «Fish Sampling of the Rivers at Eastern Macedonia-Thrace, Central Macedonia, Western Macedonia and Thessalia»
 - «Services related to the sampling and analyzes of fish fauna and phytobenthos of transitional and coastal waters: Sampling and analyzes of fish fauna and phytobenthos of transitional waters»
- ✓ LIFE 2020:
 - «Urgent measures in the Eastern Mediterranean for the long-term conservation of endangered European eel»
- ✓ Natural Environment And Innovative Actions 2020:
 - «Actions for the protection of the native species of the ichthyofauna *Eudontomyzon (Caspiomyzon) hellenicus* & *Cobitis punctilineata*»

Fisheries Management of Inland Waters and Lagoons (II)

Samplings in Rivers & Lagoons



Student Training



A scenic landscape featuring a large body of water in the center. In the foreground, there are tall, thin reeds and grasses. A small, dark-colored boat is partially visible, nestled among the reeds on the left side of the lake. The background shows a line of trees and a small, rounded hill under a bright blue sky filled with large, white, fluffy clouds. The overall scene is peaceful and natural.

Thank you!!!

Interreg



Co-funded by
the European Union

NEXT Black Sea Basin



EfxINNOs: A transformative marine monitoring network for benthic habitats



ΔΗΜΟΚΡΙΤΕΙΟ
ΠΑΝΕΠΙΣΤΗΜΙΟ
ΘΡΑΚΗΣ

DEMOCRITUS
UNIVERSITY
OF THRACE

Georgios Sylaios
Professor

Democritus University of Thrace

Nea Peramos, 2/7/2025

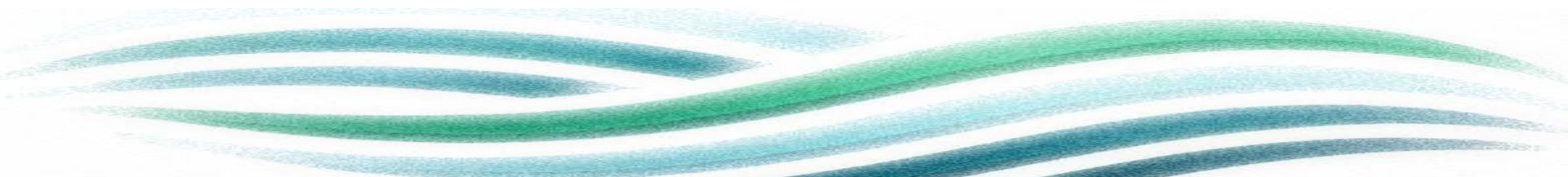

The value of seabed ecosystems

Seagrass forms the most vital but highly vulnerable part of the seascape. Seagrass meadows are the **“lungs” of the coastal ocean**. They support commercial fisheries and biodiversity, clean the surrounding water, and help **remove the excessive carbon dioxide** from the atmosphere.



The value of sea-bed ecosystems

Seagrass is essential for marine biodiversity and vital for underwater life.

They **absorb the incident wave energy** and protect our coastal zones from erosion, storms and floods.

Through **carbon sequestration**, seagrasses sink and store carbon mitigating CC.

Seagrass meadows are very efficient nitrogen strippers, **removing chemical elements** that cause harmful algal blooms.

They are the oxygen pumps of the ocean:
1 sq.m. of seagrass produces 10 L O₂/day.



Seagrass meadows under threat

Seagrass meadows are among the least protected coastal ecosystems. Almost 30% of global seagrass areas have been lost since the late nineteenth century. An estimated 7% of this vital habitat disappears each year.

The main threats to seagrass include urban, industrial, and agricultural run-off; coastal development; dredging; unregulated fishing and boating activities; and climate change.



Black Sea Seagrass communities

There are six species of seagrasses in the Black Sea: *Zostera marina* (eelgrass), *Z. noltii*, *Potamogeton pectinatus*, *Ruppia maritima*, *R. spiralis* and *Zannichellia major*.

The number of plant species in the Black Sea is **one-fourth** that of the Mediterranean.

Increasing anthropogenic pressure (industry, agriculture, aquaculture and tourism) in BS coastal zones resulted in the decline of seagrasses.

Nutrient enrichment and the consequent phytoplankton blooms limit light transparency. Epiphytes affect seagrasses negatively through shading and hypoxia.

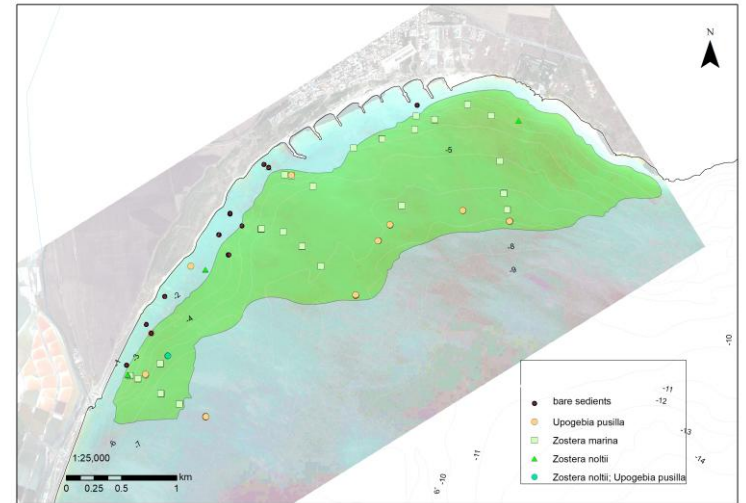

Zostera spp. seagrass meadow in front of Sarafovo, Inner Burgas Bay. Berov D, Klayn S, Deyanova D, Karamfilov V (2022) Current distribution of *Zostera* seagrass meadows along the Bulgarian Black Sea coast (SW Black Sea, Bulgaria) (2010-2020). Biodiversity Data Journal 10: e78942.

Black Sea Seagrass communities



<https://seagrassspotter.org/sighting/7167>

North Aegean Sea Seagrass communities

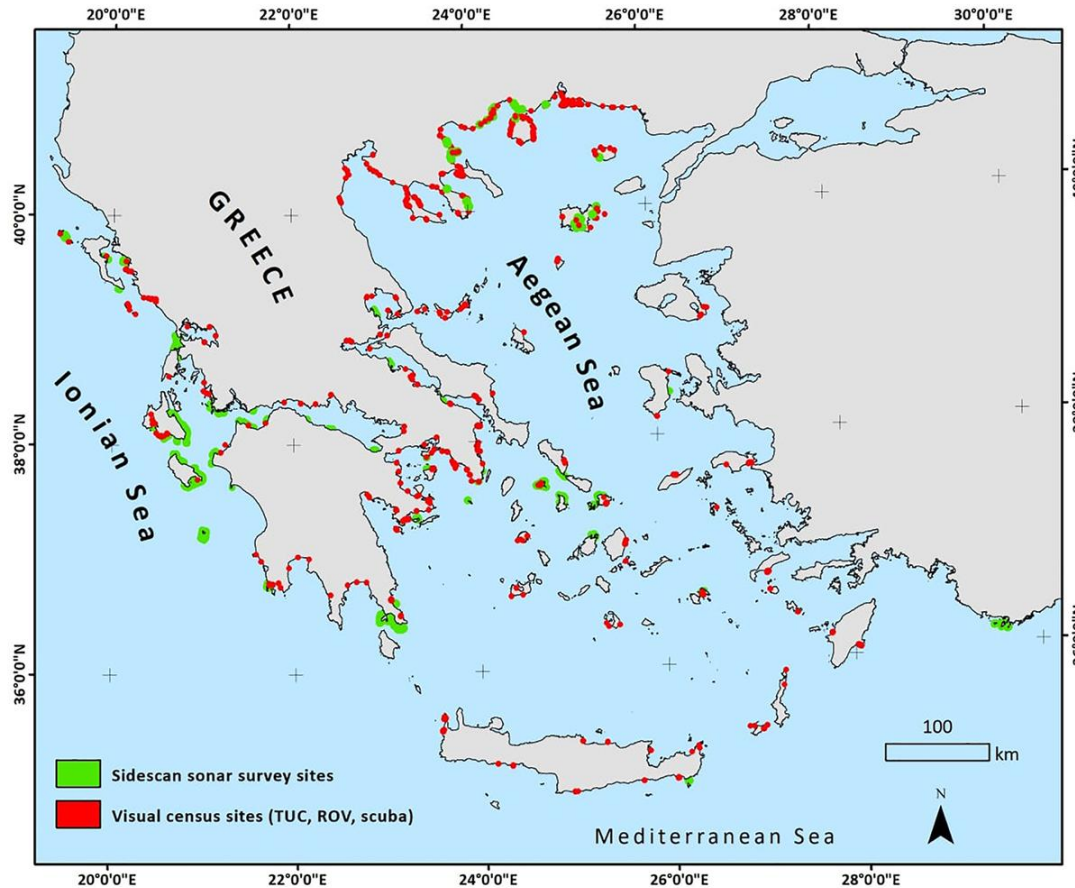

Panayotidis, P., et al., 2022.
"Seagrass meadows in the Greek Seas: presence, abundance and spatial distribution" *Botanica Marina*, vol. 65, no. 4, 2022, pp. 289-299.

North Aegean Sea Seagrass communities

Panayotidis, P., et al., 2022. "Seagrass meadows in the Greek Seas: presence, abundance and spatial distribution" *Botanica Marina*, vol. 65, no. 4, 2022, pp. 289-299.

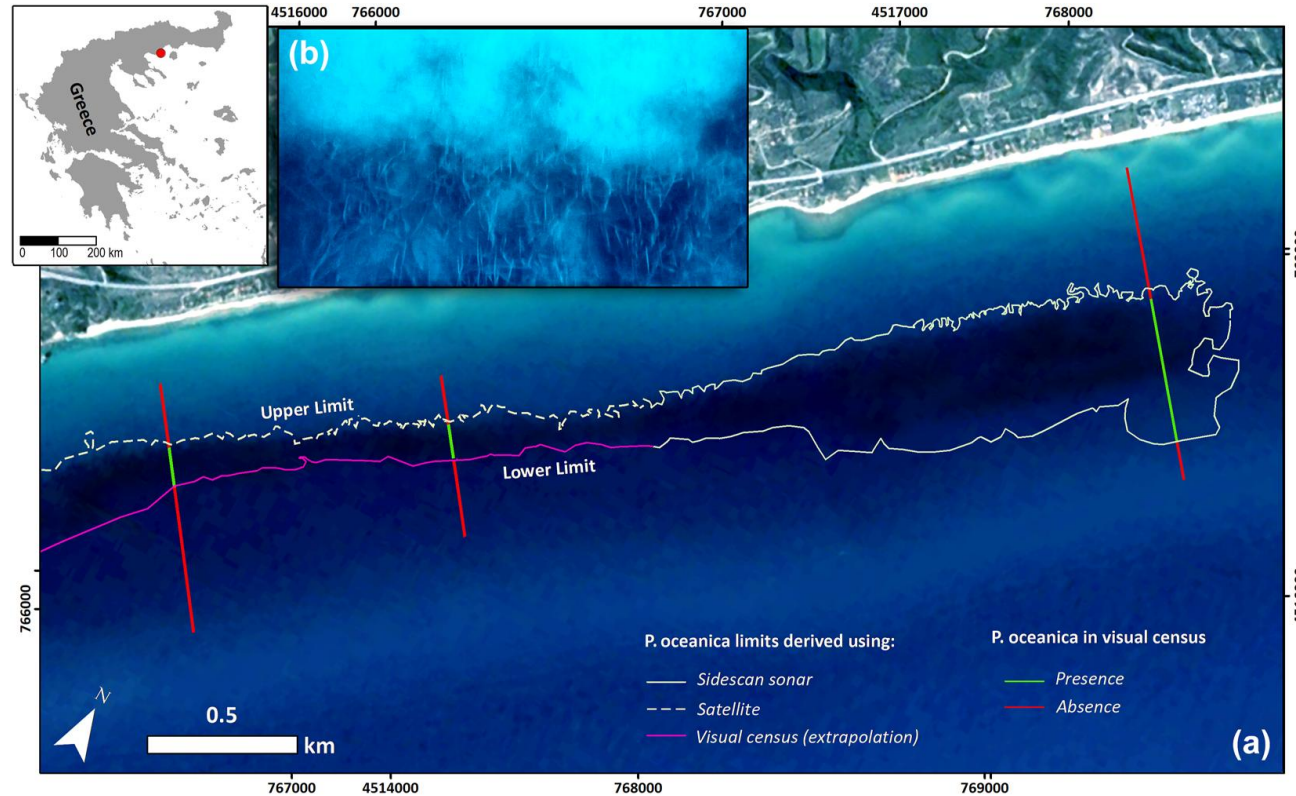



EfxINNOs

«Establishing an Innovative Marine Technology Transfer Network for Enhancing the Transition to a Sustainable Blue Economy in the Black Sea Basin»

EfxINNOs Central Scope

To develop and operate a **novel, cost-effective, technologically advanced, sustainable network of monitoring platforms**, improving existing research infrastructures, serving the joint monitoring requirements of EU Policy Instruments and the Black Sea Integrated Monitoring Assessment Program (BSIMAP), linking the Black Sea and the North Aegean Sea.



Specific Objectives

EfxINNOs will advance knowledge on benthic marine ecosystem functioning, as well as on the impact of human stressors from land-based and maritime activities.

The project will fill the gaps in **data collection, data harmonization and policy implementation** among the BSB and the Med.

The project will develop a consistent approach for the protection and restoration of the Black Sea seabed ecosystems in line to MSFD.

EfxINNOs will produce science-based policy tools to serve the directions set by the Commission on the Protection of the Black Sea Against Pollution.

The microAUV

EfxINNOs will purchase and deploy a fleet of versatile microAUVs for the underwater exploration of seagrass meadows.

Max Operational Depth	300 m
Endurance	<10 hours¹
Length	<0.9 m¹
Hull Diameter	124 mm
Weight	<9 kg
Max Speed	8 knots
Positioning	GPS, INS, SPARSE-LBL

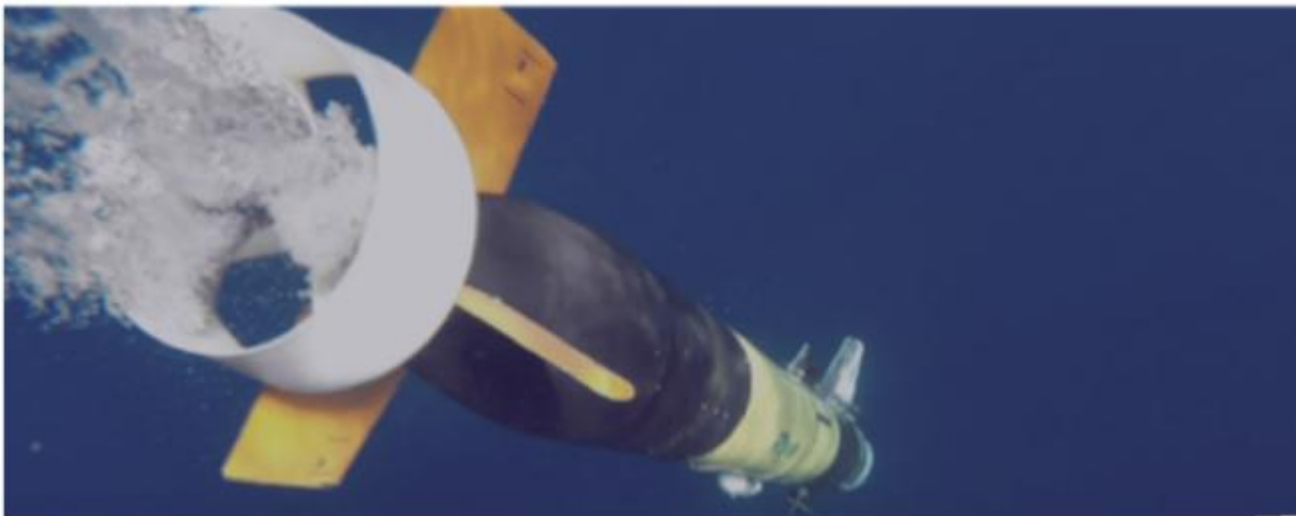

The microAUV

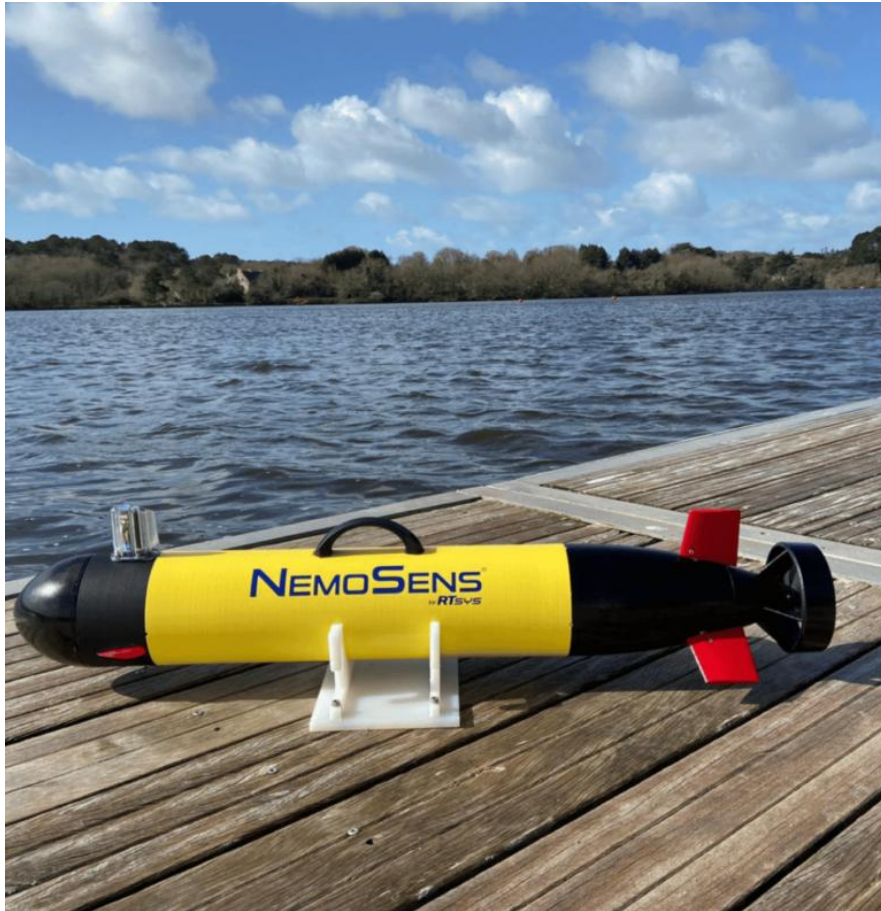

NemoSens is a compact autonomous underwater vehicle (AUV) designed for scientific, industrial, and military applications.

Lightweight and affordable, the open LINUX architecture allows users to develop their own navigation algorithms for greater flexibility and more efficient use.

NemoSens base platform can be expanded with custom measurement sensors (up to 2 kg), allowing you to extend research capabilities as needed.

Easy launch

from shore



from a quay



from a boat

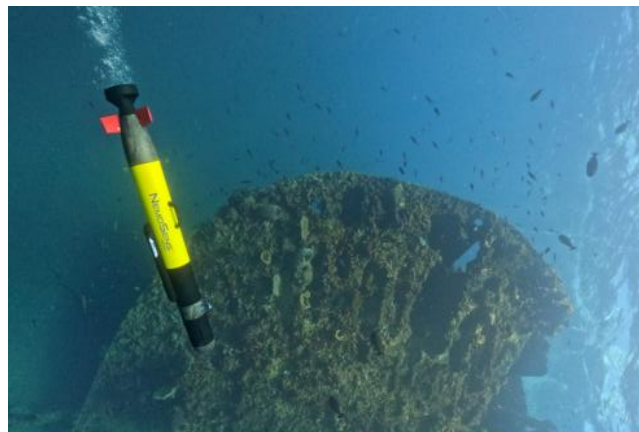



The microAUV





EfxINNOs - A Sea of Actions

- a) Utilize innovative underwater platforms (like the microAUVs) for the mapping of coastal marine environment at selected regions of the BS and the NAS
- b) Produce extensive digital seabed habitats maps, emphasizing on marine protected species, like the *Posidonia oceanica* and *Zostera marina* and *Zostera noltii* meadows
- c) Collect new data, images and videos never earlier recorded to report on coastal marine biodiversity of the BS and NAS
- d) Collect RT data on physicochemical conditions to serve maritime activities
- e) Correlate the prevailing environmental seabed conditions with the present health of seabed habitats

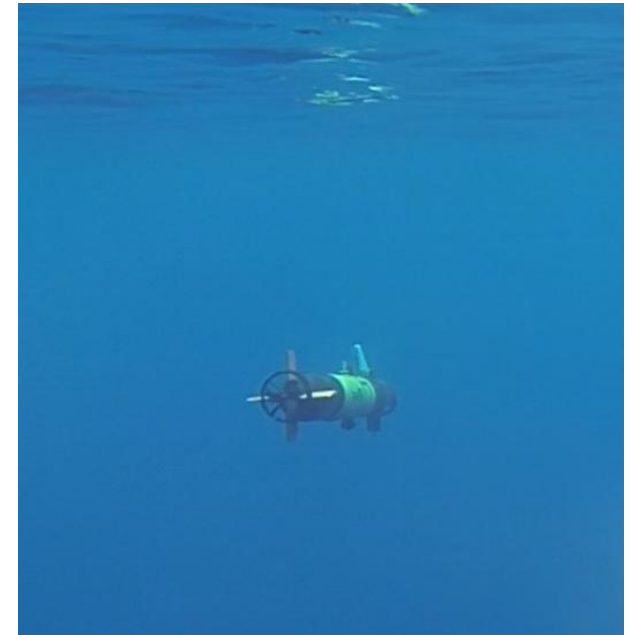

EfxINNOs - A Sea of Actions

- f) Assess the ecological significance and delineate ecologically-sensitive regions and prioritize potential marine protected areas
- g) Evaluate the existing threats that seabed habitats and benthic biodiversity face
- h) Develop policy tools and directions to protect seabed habitats from man-made impacts
- i) Link project outputs to EU Environmental Legislation (e.g., MSFD, MSPD, Biodiversity Strategy) with the objectives of SRIA and BSIMAP
- j) Communicate results and raise awareness to minimize threats (e.g., marine litter at sea bottom, trawling, pollution, human actions like shipping, cables, etc.)
- k) Educate people on the significance of coastal marine biodiversity protection
- l) Report results and policy recommendations to the Common Maritime Agenda Steering Group of the BSEC

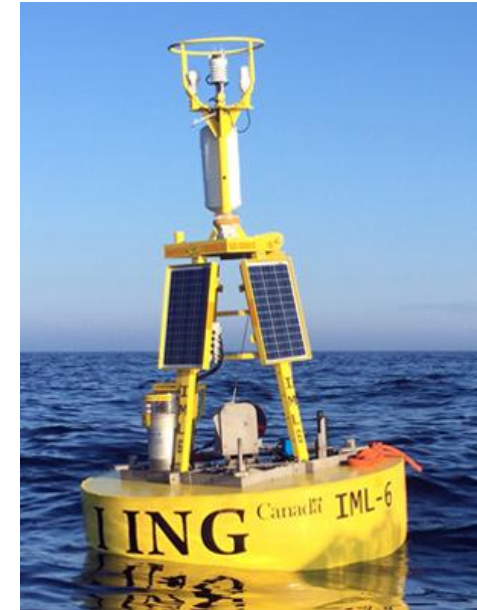

EfxINNOs - A Sea of Actions

- m) Communicate results and raise awareness to minimize threats (e.g., marine litter at sea bottom, trawling, pollution, human actions like shipping, cables, etc.)
- n) Educate people on the significance of coastal marine biodiversity protection
- o) Report results and policy recommendations to the Common Maritime Agenda Steering Group of the BSEC





The Target Audience

EfxINNOs aims to familiarize the broad BSB public with the conditions prevailing on the seabed, the current status of key benthic habitats and ecosystems, the level of marine litter pollution and the harm humans do on these vulnerable ecosystems.

The target audience of EfxINNOs at first level is the broad public.

At second level, the target audience is all supranational, national, regional and municipal authorities responsible for the protection of the BSB environment, the establishment of MPAs, and the minimization of human pressures.

Finally, the third level target audience of EfxINNOs is the marine and maritime users, namely fishers, aquaculture operators, port authorities, shipping companies, oil and gas operators, touristic agents, etc.



Supporting EU Policies



Descriptor 1: Biodiversity is maintained



Descriptor 2: Non-indigenous Species do not adversely alter the ecosystem



Descriptor 3: The population of commercial fish species is healthy



Descriptor 4: Elements of food webs ensure long-term abundance and reproduction



Descriptor 5: Eutrophication is minimised



Descriptor 6: The sea floor integrity ensures functioning of the ecosystem

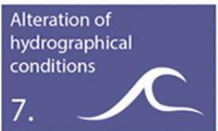

Descriptor 7: Permanent alteration of hydrographical conditions does not adversely affect the ecosystem



Descriptor 8: Concentrations of contaminants are at levels not giving rise to pollution effects.



Descriptor 9: Concentrations of contaminants are at safe levels.



Descriptor 10: Marine litter does not cause harm

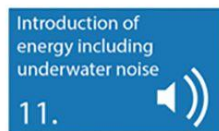

Descriptor 11: Energy including Underwater Noise





Expand Monitoring Capacities

The screenshot displays the EMODnet Map Viewer interface. At the top left, the European Commission logo and the text "EMODnet Map Viewer" are visible. On the right, there is a language selector set to "English". The main interface is divided into a left sidebar and a central map area. The sidebar contains a "Layers" panel with a "Catalogue" section. Under "Composite data products (created by EMODnet)", the "Seagrass cover in Europe (2023)" layer is checked. Other layers include "Biogenic substrate in Europe (2023)", "Coralligenous and other calcareous biocon...", "Mangrove cover and composition (2023)", "Live hard coral cover in Europe (2023)", and "Macroalgal canopy cover in Europe (2023)". Below this is a section for "Composite data products (created by others)" and "EMODnet broad-scale seabed habitat map for Europe" with an "Add external layers" button. At the bottom of the sidebar, there are dropdown menus for "Marine regions" (set to "Search for a region ...") and "Change basemap" (set to "EMODNET World Base Layer"). The central map area shows a bathymetric map of the Black Sea Basin with several green dots indicating monitoring locations. On the right side of the map, there are navigation controls including zoom in (+), zoom out (-), home, full screen, pan, 3D, and share icons. A scale bar at the bottom left indicates 100 km, and the coordinates 31.10713, 43.17816 are displayed.

Interreg



Co-funded by
the European Union

NEXT Black Sea Basin



Interconnect EfxINNOs to EU Infrastructures



EfxINNOs databases
and ecological
indicators

dynamic, and directly
connected



Implemented by
**MERCATOR
OCEAN
INTERNATIONAL**



EMODnet



European Marine
Observation and
Data Network



EDITOInfra

European Digital Twin Ocean



NEXT Black Sea Basin

The Time Plan

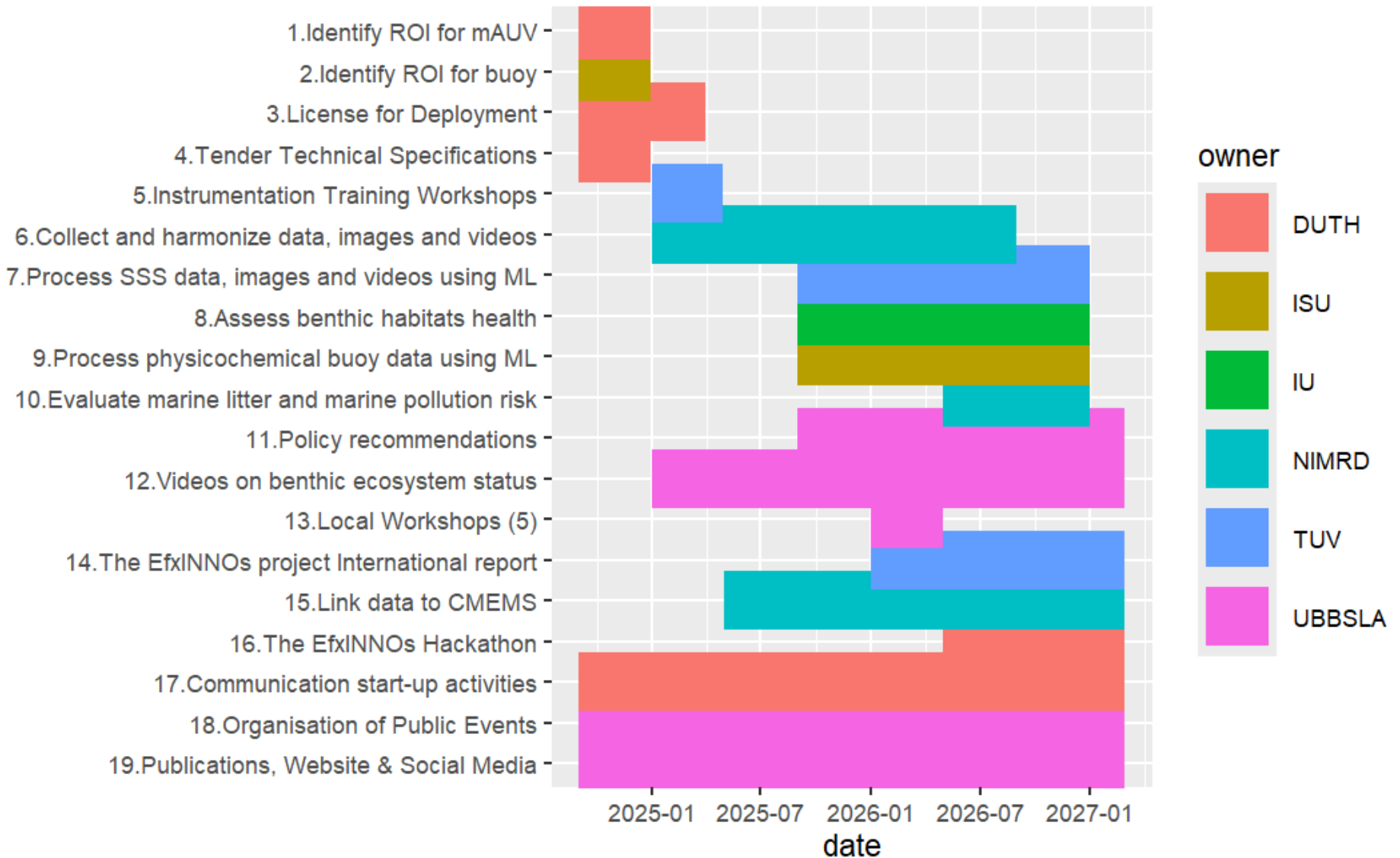



Budget Overview

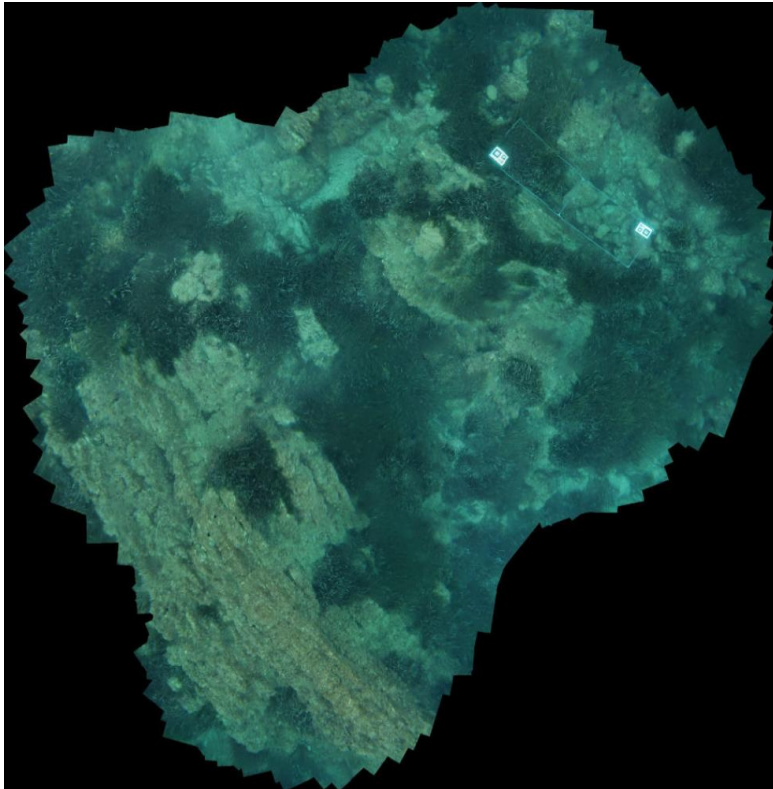

Interreg Funds	1,479,283.56 Euros
Other public contribution	164,364.84 Euros
Total project budget	1,643,648.40 Euros



The Consortium

1. Democritus University of Thrace – DUTH (EL, Leader)
2. Union of Bulgarian Black Sea Local Authorities - UBBSLA (BG, P1)
3. National Institute for Marine Research and Development “Grigore Antipa” – NIMRD (RO, P2)
4. Ilya State University – ISU (GE, P3)
5. Istanbul University – IU (TR, P4)
6. Technical University of Varna – TUV (BG, P5)





ROIs Definition - Bulgaria

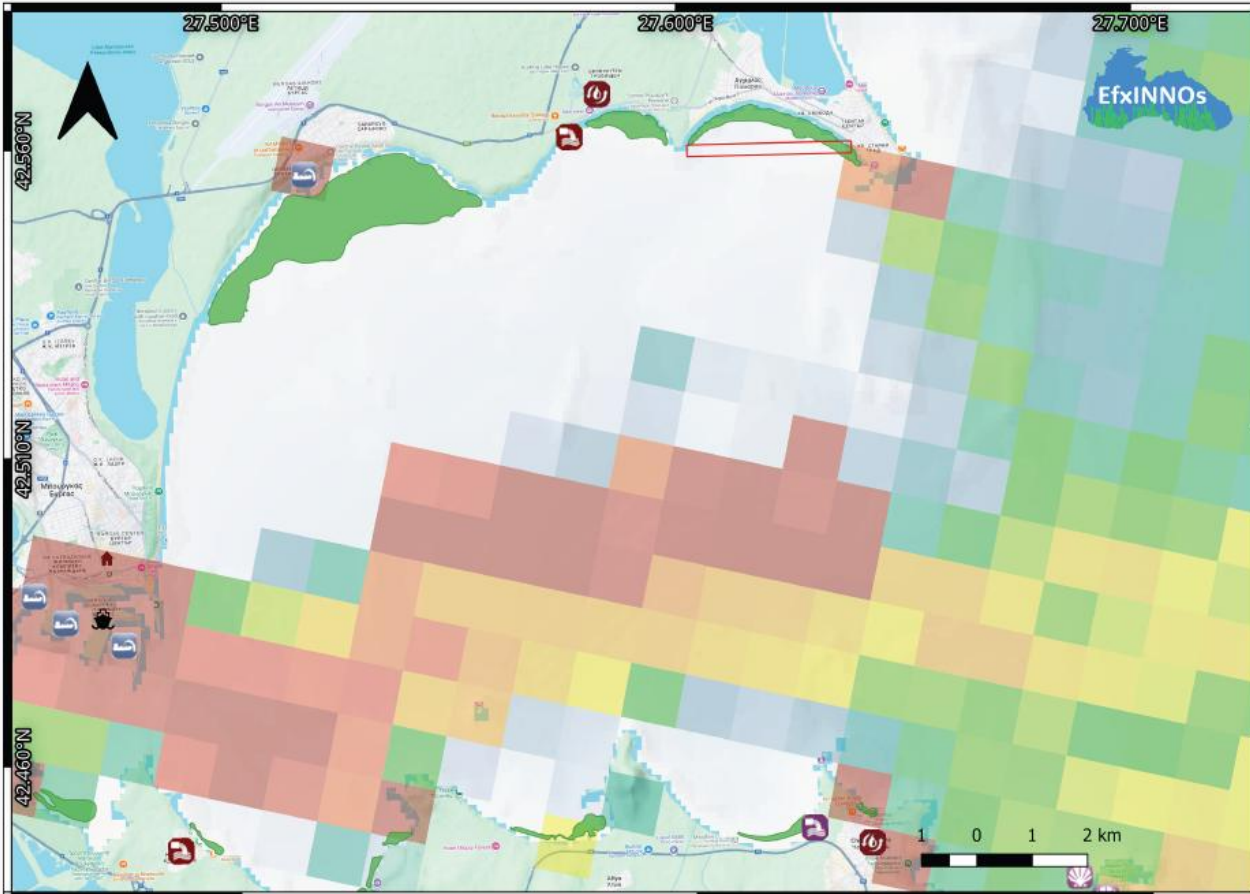

Bulgaria's ROIs	Abandoned	Dredging
Human Activities	Active	Vessel Density Hours per Square Km per Month
Cities	Application submitted	
Main Ports	N/A	Seagrass Meadows
Wind Farms	Not in use	
Discharge Points	Planned	
Active	Pre-commissioning	
Inactive	Proposed	
Temporary inactive	Under construction	
Treatment Plants		
Active	Shellfish Production	
Inactive	Clams	
Temporary inactive	Mixed (other)	
Finfish Production	Mussels	
Flatfish	Mussels-Oysters	
Other	N/A	
Salmonids	Oysters	
Sea bass-sea bream and other coastal fish	Specialised (other)	
Tuna		



ROIs Definition - Romania

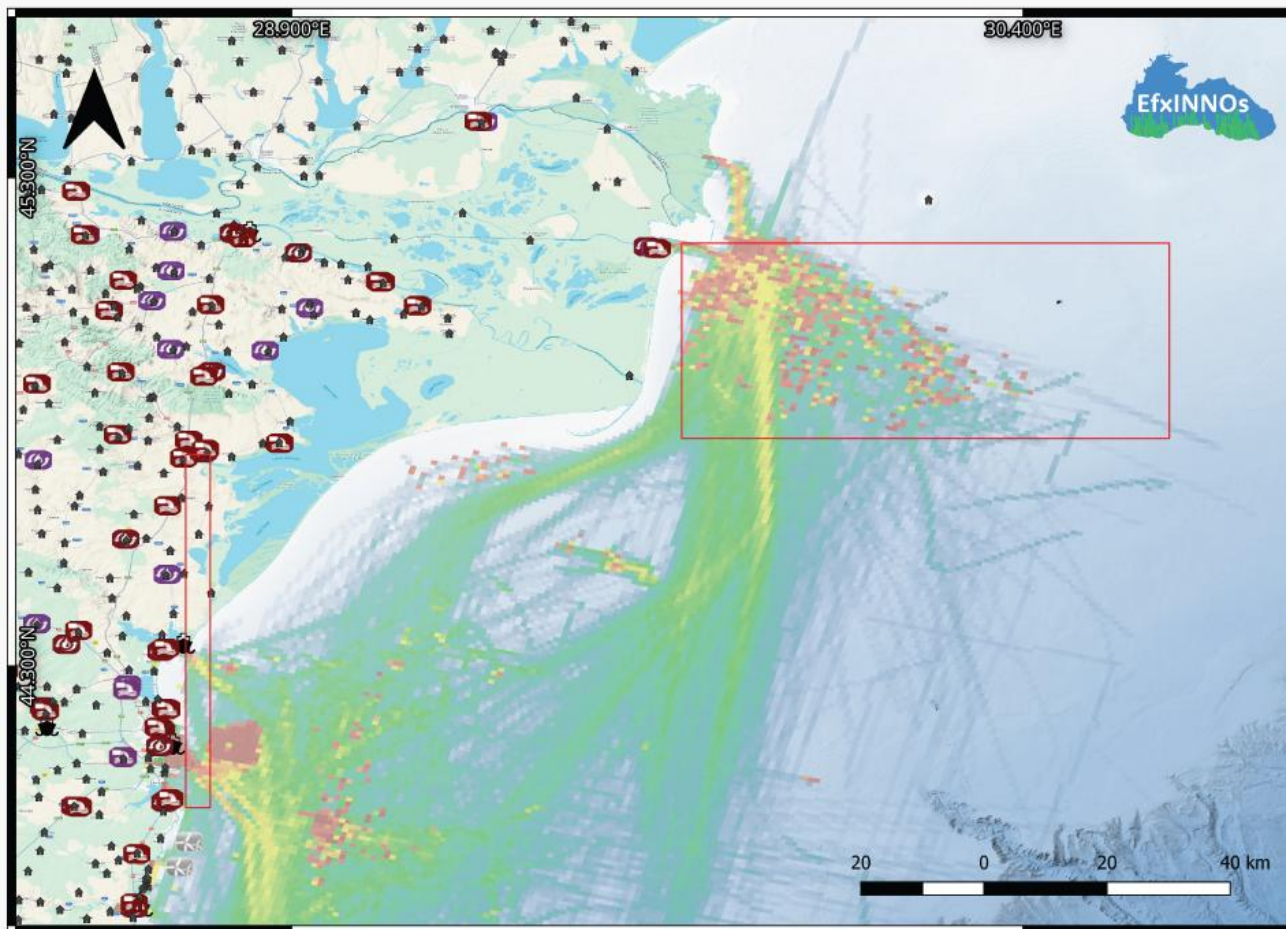

Romania's ROIs	Pipelines/Offshore Installations Abandoned	Dredging
Human Activities	Active	Vessel Density
Cities	Application submitted	100+
Villages	N/A	20
Main Ports	Not in use	10
Discharge Points	Planned	5
Active	Pre-commissioning	2
Inactive	Under construction	0.5
Temporary inactive	Shellfish Production	Hours per Square Km per Month
Treatment Plants	Clams	
Active	Mixed (other)	
Inactive	Mussels	
Temporary inactive	Mussels-Oysters	
Finfish Production	N/A	
Flatfish	Oysters	
Other	Specialised (other)	
Salmonids		
Sea bass-seastrim and other coastal fish		
Tuna		

ROIs Definition - Turkey

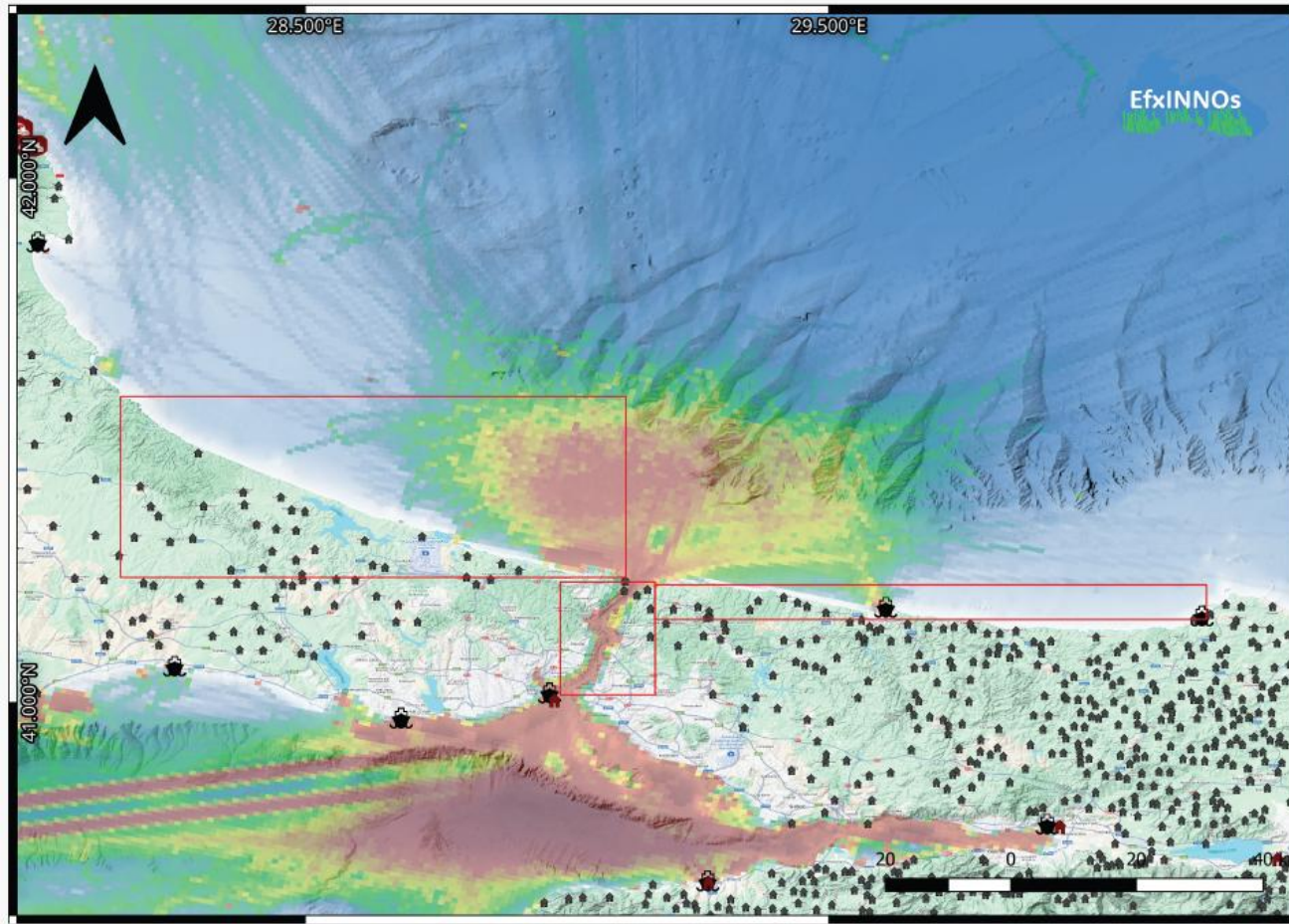

Türkiye's ROIs	Pipelines/Offshore Installations	Dredging
Human Activities	Abandoned	Dredging
Cities	Active	Vessel Density
Villages	Application submitted	
Main Ports	N/A	100+
Wind Farms	Not in use	20
Discharge Points	Planned	5
Active	Pre-commissioning	2
Inactive	Proposed	0.5
Temporary inactive	Under construction	Hours per Square Km per Month
Treatment Plants	Shellfish Production	
Active	Clams	
Inactive	Mixed (other)	
Temporary inactive	Mussels	
Finfish Production	Mussels-Oysters	
Flatfish	N/A	
Other	Oysters	
Salmonids	Specialised (other)	
Seabass-seabream and other coastal fish		
Tuna		



ROIs Definition - Greece

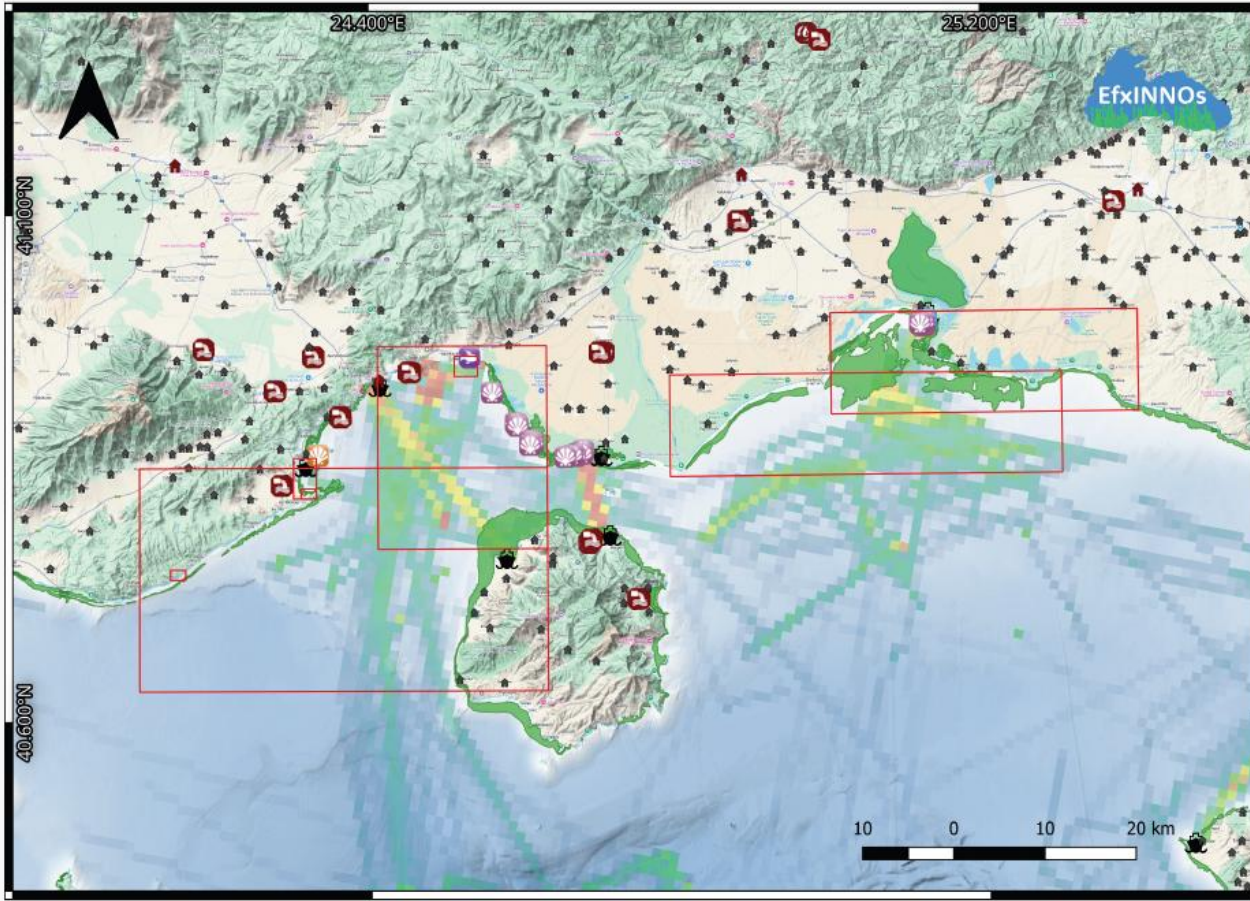

Greece's ROIs	Finfish Production	Dredging
Human Activities	Flatfish	Dredging
Cities	Other	Seagrass Meadows
Villages	Salmonids	Vessel Density
Main Ports	Sea bass-seabream and other coastal fish	100+ 20 10 5 2 0.5 Hours per Square Km per Month
Wind Farms	Tuna	
Approved	Pipelines/Offshore Installations	
Dismantled	Abandoned	
Planned	Active	
Production	Application submitted	
Under Construction	N/A	
Test site	Not in use	
Discharge Points	Planned	
Active	Pre-commissioning	
Inactive	Proposed	
Temporary inactive	Under construction	
Treatment Plants	Shellfish Production	
Active	Clams	
Inactive	Mixed (other)	
Temporary inactive	Mussels	
	Mussels-Oysters	
	N/A	
	Oysters	
	Specialised (other)	

Buoy Tendering and Delivery in Georgia (ISU)



- RT recording of physicochemical parameters from the water surface
- Water quality measurements of sea surface temperature, electrical conductivity, turbidity, and dissolved oxygen
- Buoy deployment at Poti Port
- Platform to collect, process, and visualize data

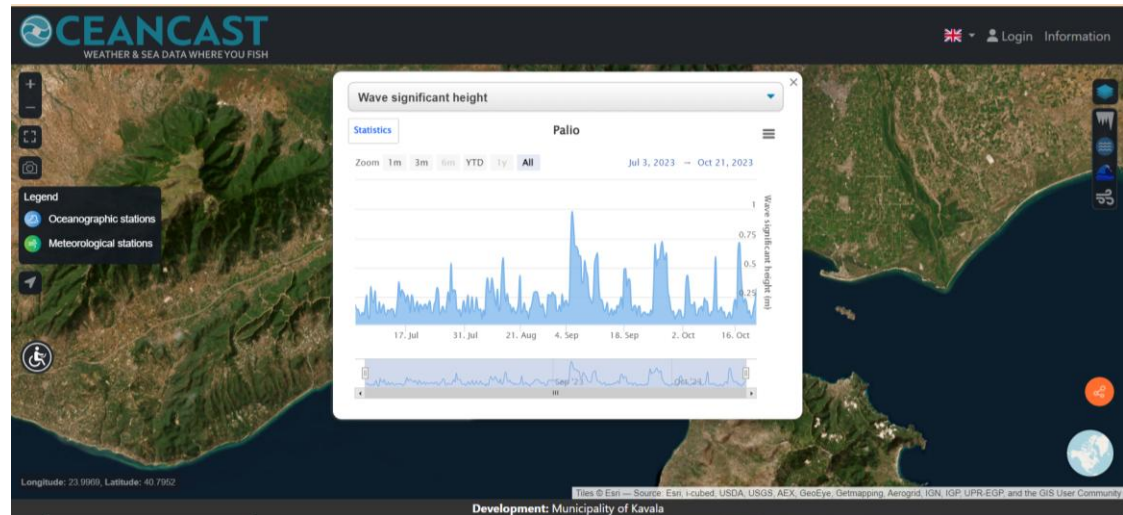
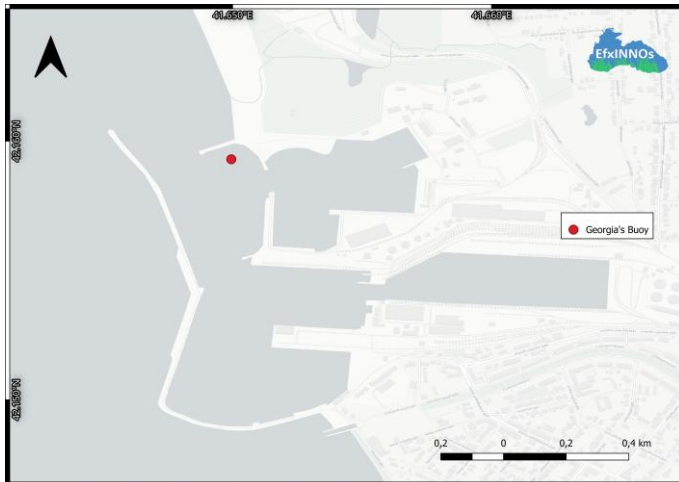

The Varna Workshop – Our First Public Event

- More than 60 attendees
- Stakeholders from government, local authorities, research institutes, and universities
- Scientists, students, civil society, and industry contributed to the event.
- EfxINNOs was unveiled, project objectives were presented, networking with stakeholders was fostered.
- A press conference was featured during the workshop, attracting significant interest from journalists and increasing the project's visibility.





Our first Newsletter



#1 NEWSLETTER

February, 2025



Waves of Innovations!

Welcome to the first newsletter of the EfxINNOs project, supported by the Interreg NEXT Black Sea Basin Programme.



Discover more project updates!



ILIA STATE UNIVERSITY (ISU) ALREADY SELECTED THE PILOT AREA IN GEORGIA

The Poti New Port area was selected as EfxINNOs pilot for the deployment of a physico-chemical buoy at coordinates 42.09.558'N; 41.38.997'E. This site ensures:

- Safe deployment: The location is relatively sheltered yet exposed enough for meaningful data collection.
- Scientific relevance: The data collected will allow comparisons with earlier findings, particularly regarding chlorophyll concentrations and organic pollutants.

The buoy's sensors will measure parameters such as temperature, pH, conductivity, turbidity, salinity, dissolved oxygen, and chlorophyll-a to provide continuous chemical monitoring of the Black Sea waters.

ISU has initiated and made significant progress in securing permissions for buoy deployment. Key stakeholders engaged include:

- Poti Port Administration
- Maritime Transport Agency
- State Hydrographic Service

The licensing process is nearing completion, ensuring compliance with necessary regulations for deployment in Georgian waters.



Moreover, the project activities implemented in Türkiye by our project partner **Istanbul University (IU)** will be part of Programme filming mission. During the period 20th – 23rd of May, 2025 the team of TESIM, the technical assistance project funded by the European Commission to support the implementation of cross-border cooperation programmes under the Neighbourhood Policy (ENI CBC, Interreg NEXT) will be in Türkiye on their next audiovisual mission to showcasing the activities implemented there in the frame of EfxINNOs project.

ISU has completed the buoy's and its sensors' technical specifications. Currently, the procurement of a buoy is in process, and just after delivery, the installation will be started.

The Varna Study Visit – Searching for Kiosk Sites

- Check “on ground” the various options available for the deployment of the info kiosks
- Provide a better understanding of the project's scope and impact to the involved local authorities
- Make a tangible connection of the research and monitoring activities planned for the Bulgarian Black Sea coast with the place-based local development operations.





The EfxINNOs Communication Package



© EfxINNOs Responsible for publication
Union of Bulgarian Black Sea Local Authorities (UBSLA)

<https://envrio.org/efxinno>



Duration
08/2024 - 02/2027

Total budget
1.643.648,40 €

EU funding
1.479.283,56 €

BSB00193 - EfxINNOs

EfxINNOs is a transnational project that aims to establish and operate an Innovative Marine Technology Transfer Network for enhancing the transition to a sustainable Blue Economy in the Black Sea Basin. EfxINNOs will develop a novel, cost-effective, technologically-advanced network of platforms collecting data, images and videos on the marine biodiversity of the Black Sea and the North Aegean Sea.

Co-funded by
the European Union



print.xirafi.gr
ΔΕΙΓΜΑ ΕΞΩΦΥΛΛΟΥ
ΓΙΑ ΣΗΜΕΙΩΜΑΤΑΡΙΟ
& ΔΕΙΓΜΑ ΣΤΥΛΟ:



print.xirafi.gr
ΔΕΙΓΜΑ ΓΙΑ
ΜΠΛΟΥΖΑΚΙΑ:
μπροστά όψη



πίσω όψη



The Poster

The Leaflet

Interreg



Co-funded by
the European Union

NEXT Black Sea Basin



The EfxINNOs Volunteers' Package



print.xirafi.gr

ΔΕΙΓΜΑ ΓΙΑ
ΜΠΛΟΥΖΑΚΙΑ:

μπροστά όψη



πίσω όψη



The T-Shirts



print.xirafi.gr

ΔΕΙΓΜΑ ΓΙΑ
ΤΣΑΝΤΕΣ:



The Bag

Interreg



Co-funded by
the European Union

NEXT Black Sea Basin



The EfxINNOs Web Site



About Us

Efxinnos Project

EfxINNOs is a collaborative project aimed at developing a sustainable and advanced marine monitoring network to assess and protect the benthic ecosystems of the Black Sea and North Aegean Sea. Utilizing a combination of mobile and static platforms, including autonomous underwater vehicles (AUVs) and remotely operated vehicles (ROVs), the project will collect and analyze data on marine biodiversity, human impacts, and ecosystem health using machine learning and AI tools. The initiative aligns with EU environmental policies and promotes transnational cooperation to fill gaps in data collection, harmonization, and policy implementation. EfxINNOs will produce science-based recommendations, foster professional development through workshops and training, and raise public awareness about marine pollution, conservation, and the sustainable Blue Economy. The project involves a diverse partnership of research institutions across the Black Sea Basin, aiming to create a lasting network for ecosystem protection and responsible marine resource management.

<https://envrio.eu/efxinnos/>

Interreg



Co-funded by
the European Union

NEXT Black Sea Basin

Interreg



Co-funded by
the European Union



NEXT Black Sea Basin

BSB00193

EfxINNOs

ROV TRAINING WORKSHOP

April 18, 2025 | Istanbul

Limited
spots



"Apply now"



A training session will be held as part of the EfxINNOs Project to teach how to operate the ROV device, which will be used to study seagrass meadows in the Black Sea.

[efxinno_tr](https://www.instagram.com/efxinno_tr)

[efxinno_tr](https://twitter.com/efxinno_tr)

efxinno@istanbul.edu.tr

<https://efxinno.istanbul.edu.tr>



EfxINNOs

Establishing and Operating an Innovative Marine Technology Transfer Network for
Enhancing the Transition to a Sustainable Blue Economy in the Black Sea Basin

EfxINNOs ROV Training Workshop

Date: Friday, 18 April 2025

Time: 08.30-17.00

Meeting point: Istanbul University, Faculty of Aquatic Sciences, 16 Mart Şehitleri Str., No: 2
Vezneciler, Fatih, İstanbul

Venue: YUNUS-S R/V Haydarpaşa Port, İstanbul

AGENDA

- | | |
|-------|--|
| 08.30 | Meet at the Faculty of Aquatic Sciences, IU |
| 08.45 | Transfer to the YUNUS-S R/V (from IU to Haydarpaşa Port) |
| 10.00 | Departure from Haydarpaşa Port |
| 10.20 | Presentation of the day's activities |
| 12:00 | ROV Theoretical training & Technical briefing |
| 13.00 | Lunch break |
| 14.00 | Preparation of the field equipment and supplies |
| 14.15 | ROV Practical session, field survey |
| 16.00 | Post-Survey examination of ROV recordings |
| 16.30 | Discussions and conclusion |
| 17.00 | Return to Faculty of Aquatic Sciences, IU |



The EfxINNOs Partnership



Interreg



Co-funded by
the European Union

NEXT Black Sea Basin



Thank you!



Interreg



Co-funded by
the European Union



NEXT Black Sea Basin

Buoy deployment and data in Georgia

**Ketevan Kupatadze
Ilia State University**

3.06.2025, KAVALA

Interreg



Co-funded by
the European Union



NEXT Black Sea Basin

ISU TEAM-KETEVAN KUPATADZE



Interreg



Co-funded by
the European Union



NEXT Black Sea Basin

ISU TEAM- MAMUKA MODEBADZE

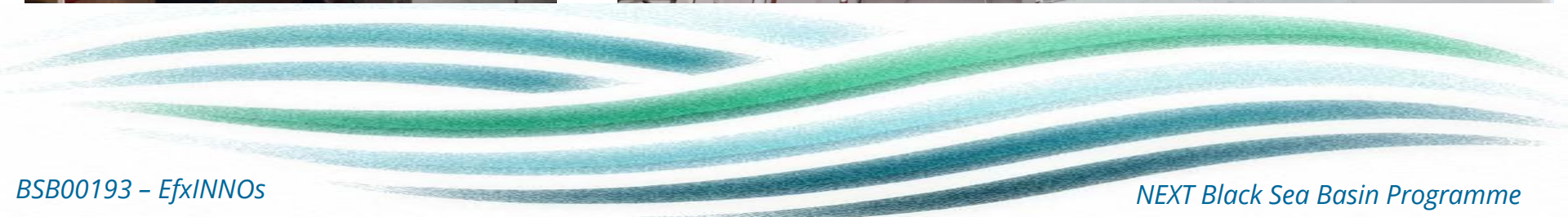

Interreg



Co-funded by
the European Union



NEXT Black Sea Basin

ISU TEAM- TAMAR EDISHERASHVILI



Interreg



Co-funded by
the European Union



NEXT Black Sea Basin

Outline of the Presentation

Identify an area of interest for the physico-chemical
buoy installation and deployment process.

Data collected by surface buoy;

Identify an area of interest for the physico-chemical buoy installation

The **Poti Sea Port** is a major seaport and harbor off the eastern Black Sea coast at the mouth of the Rioni River in Poti. Location at [42°9'18"N 41°39'16"E](#)

The Poti seaport is a cross point of the Trans-Caucasian Corridor, a multinational project which connects the Romanian port of Constanta and Bulgarian port Varna with the landlocked countries of the Caspian region and Central Asia.



Identify an area of interest for the physico-chemical buoy installation

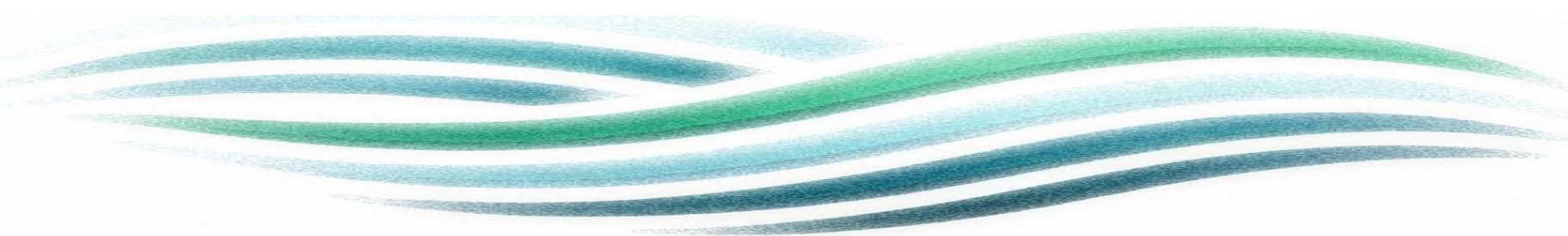
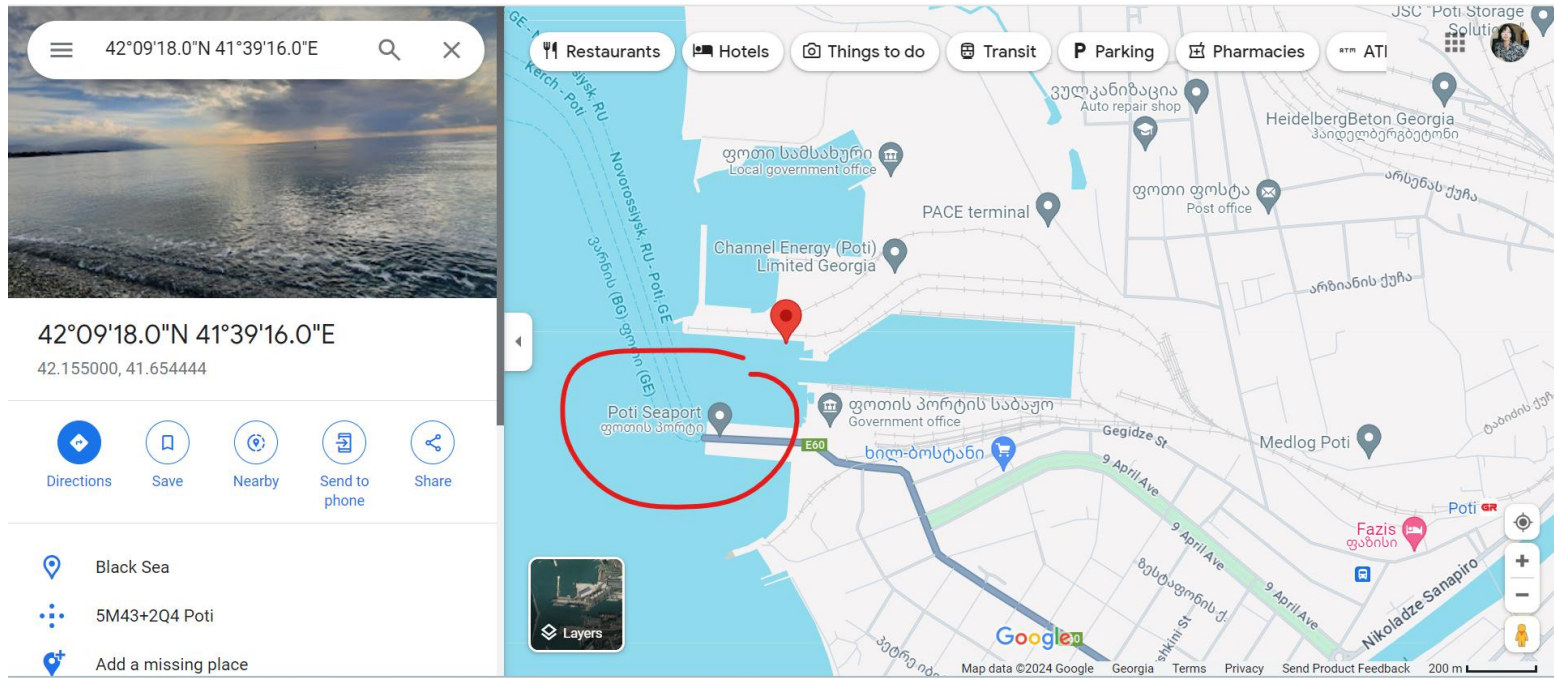

Interreg



Co-funded by
the European Union



NEXT Black Sea Basin

Buoy deployment-29 April,2025





Buoy deployment-29 April, 2025

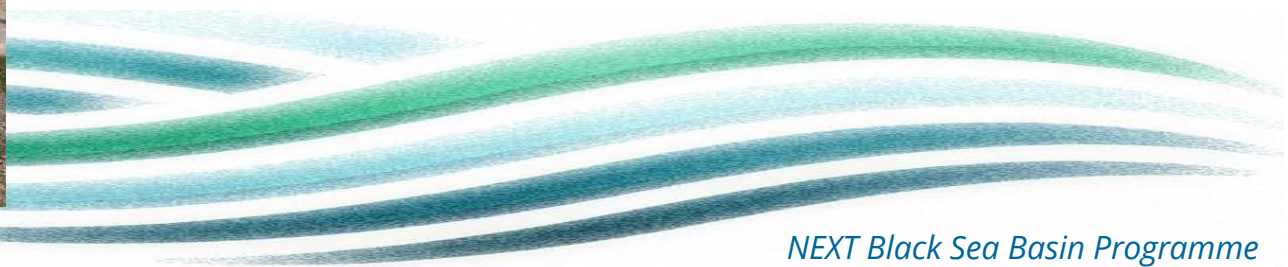
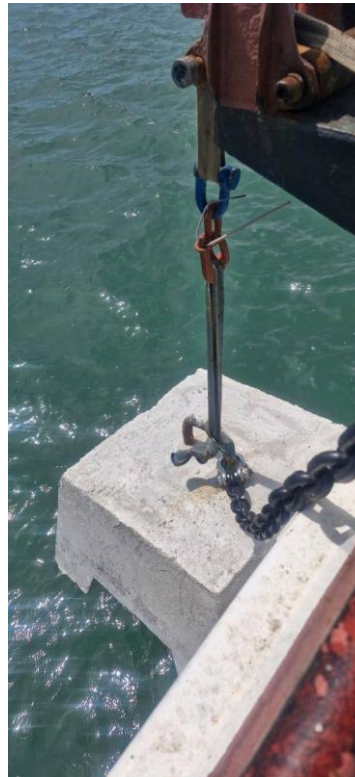

Buoy deployment



Temperature; conductivity
electrode (0-500 mS/cm)
(salinity) turbidity
analyzer(no
wiper)(0~10/100/1,000/4,0
00 NTU),
chlorophyll a analyzer(no
wiper)(0~500 mg/L)



Oxygen Saturation

Georgia

Measurements Data

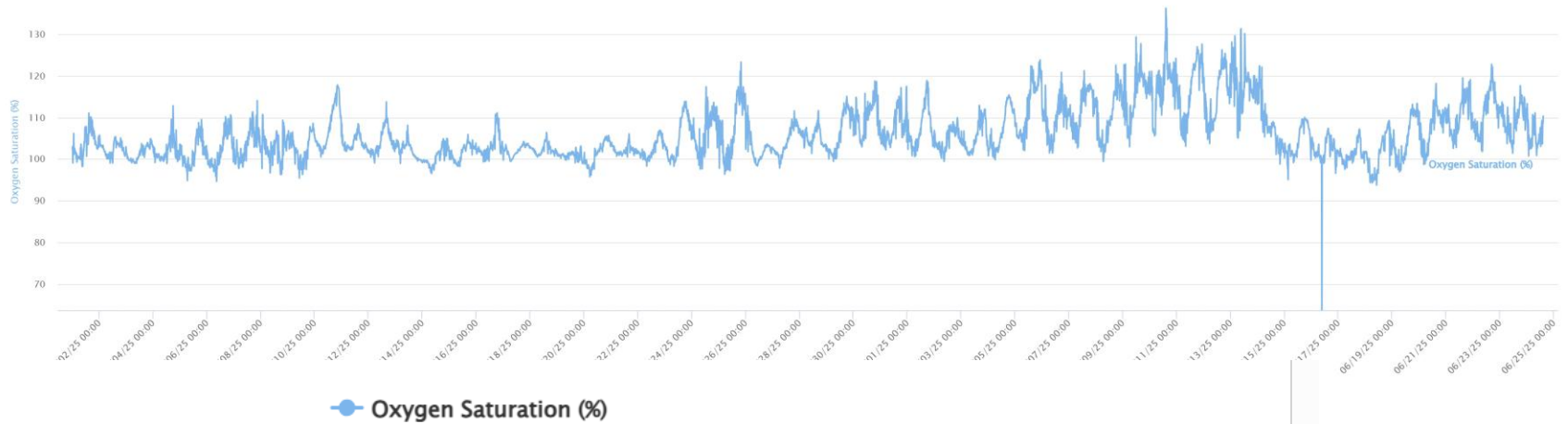



- Oxygen saturation values above 100 indicate supersaturation, which can happen during periods of intense photosynthesis, typically by aquatic plants or algae, especially under strong sunlight.
- The **average value of 106.05** suggests that the water body experienced periods of significant biological activity.
- The **minimum value of 63.63** indicates some periods of low oxygen saturation, which could potentially stress aquatic life if prolonged.
- A wide range between min and max suggests fluctuating environmental or biological conditions, possibly due to temperature changes, algal blooms, or varying flow rates.



Chlorophyll

Georgia
Measurements Data

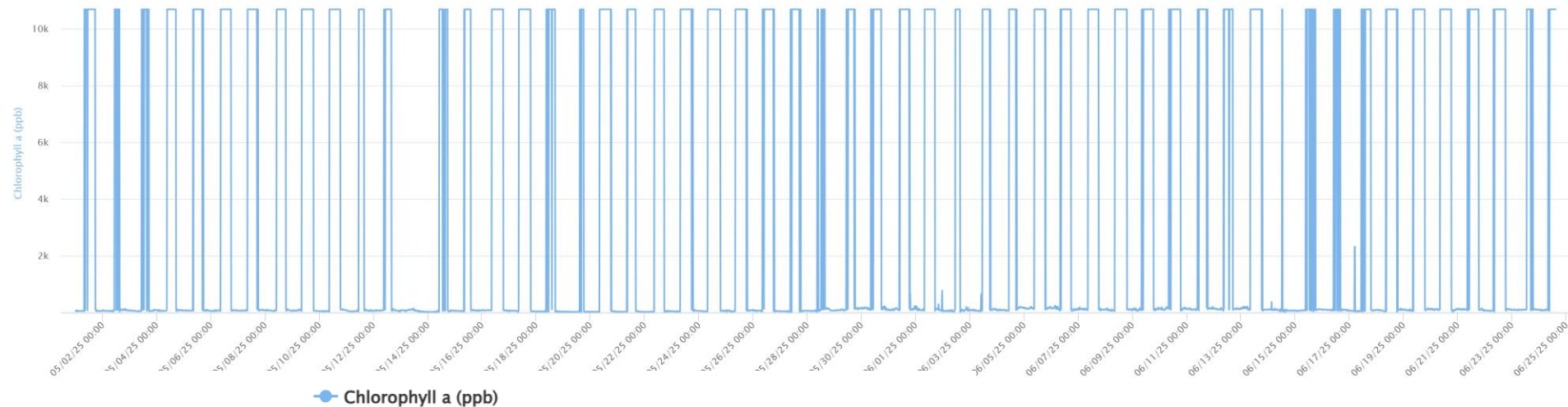

05/01/25 00:00 - 06/24/25 14:30

05/01/25 00:00 - 06/24/25 14:30

Chlorophyll a (ppb)

Y Axis Values:

3

10684

Submit

Minimum value = 3 | Maximum value = 10684 | Average value = 3516.08

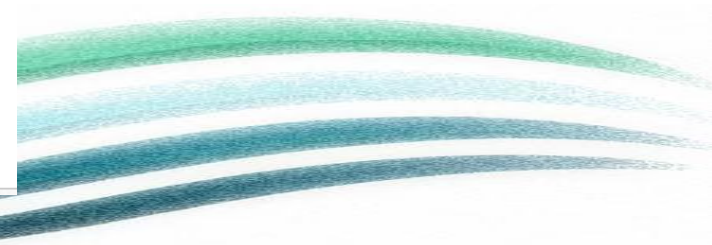

- Chlorophyll-a is a key indicator of algal biomass.
- Values above **10,000 ppb** (10 mg/L) indicate a very high concentration, possibly reflecting an algal bloom.
- The **average of 3,516 ppb** also points to consistently elevated algal activity over the monitoring period.
- The relationship between high chlorophyll and supersaturated oxygen (noted above) further supports the likelihood of significant photosynthetic activity, possibly linked to eutrophication or nutrient loading.

Humic substances (HS) mainly **humic acids constitute the major fraction of natural organic matter in water supplies**. They play an important role in the formation of harmful disinfection by products.

The main component is of fulvic acid, dissolves well in sea water and is active throughout the pH range.

CH₃Sn; CH₃Hg; CH₃Pb; CH₃Cd-CH₃Met;

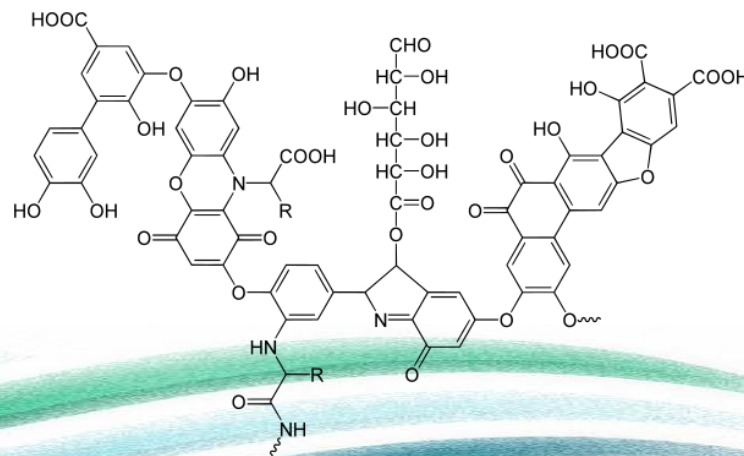



Save Report

Chart

DATA VIEW VIA CHART

Found 12 Measurements

Georgia

Measurements Data

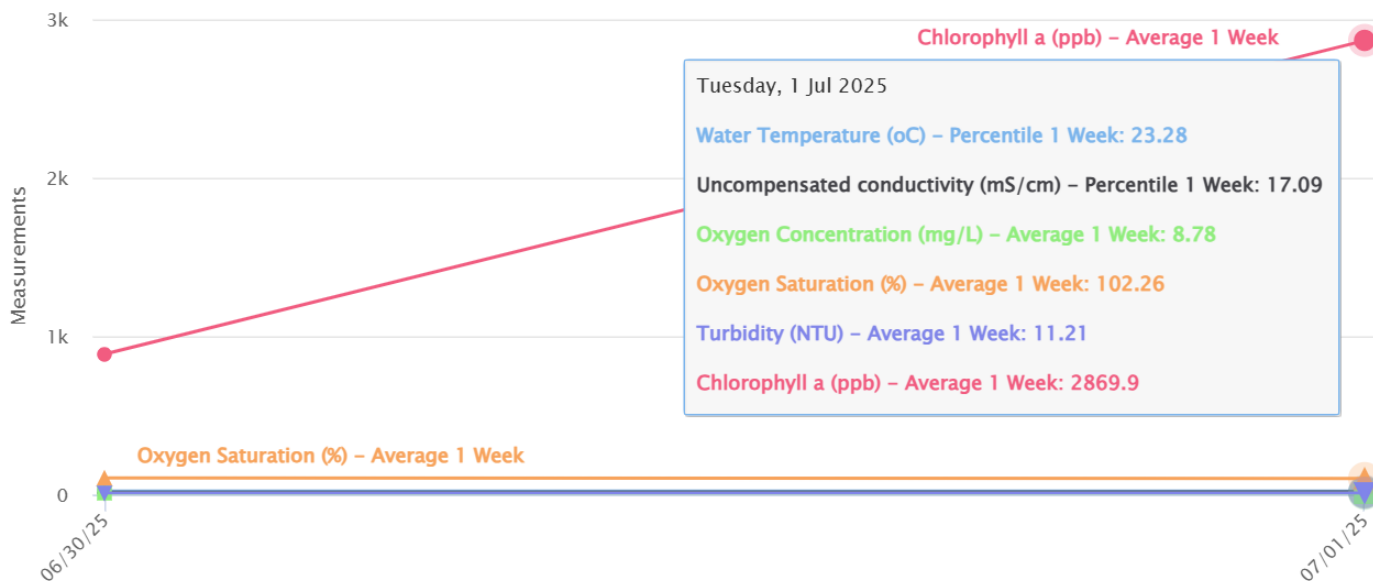



Chlorophyll Measurement with Satellite remote-sensing-2017 Spring

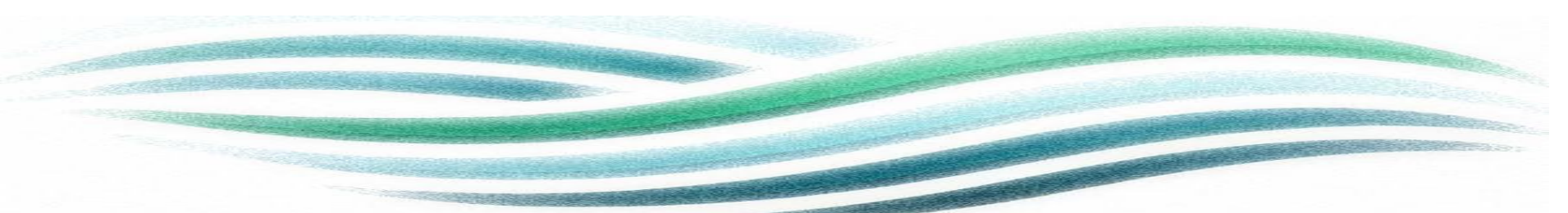
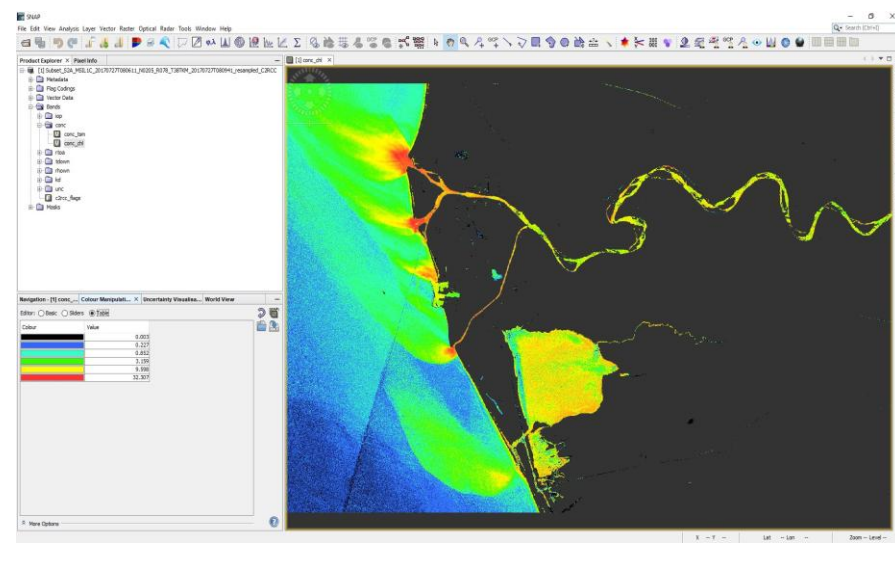
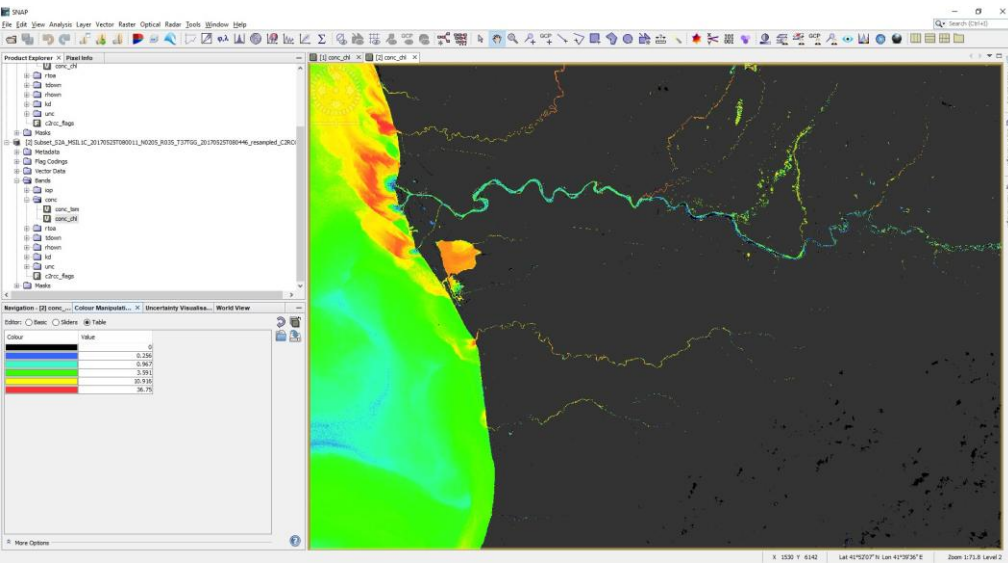

Interreg



Co-funded by
the European Union



NEXT Black Sea Basin

Chlorophyll Measurement with Satellite remote-sensing-2020 Spring

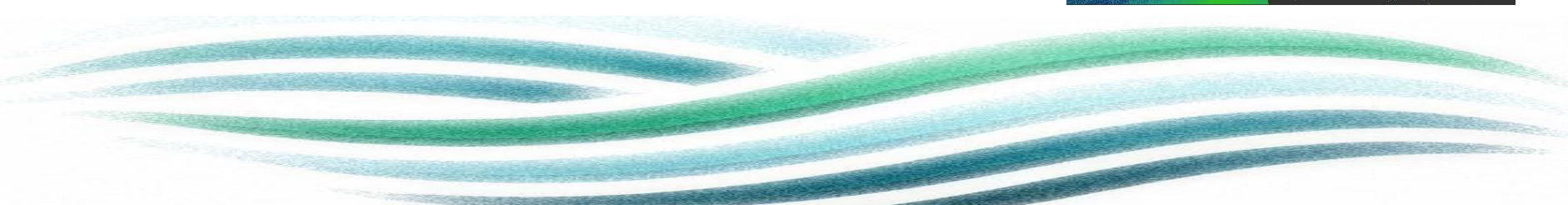
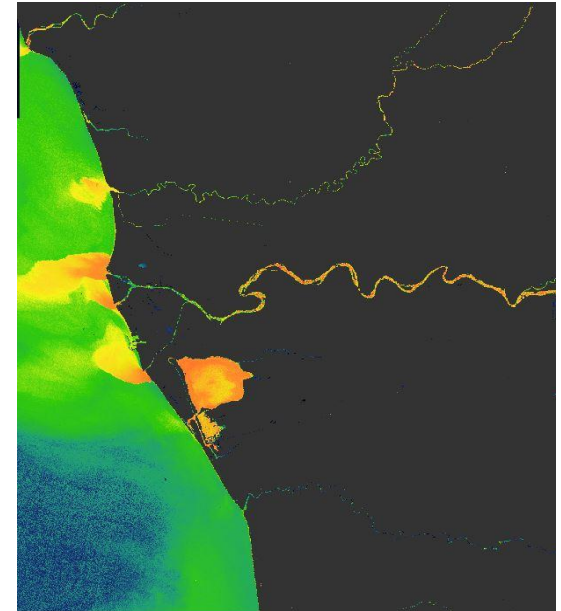
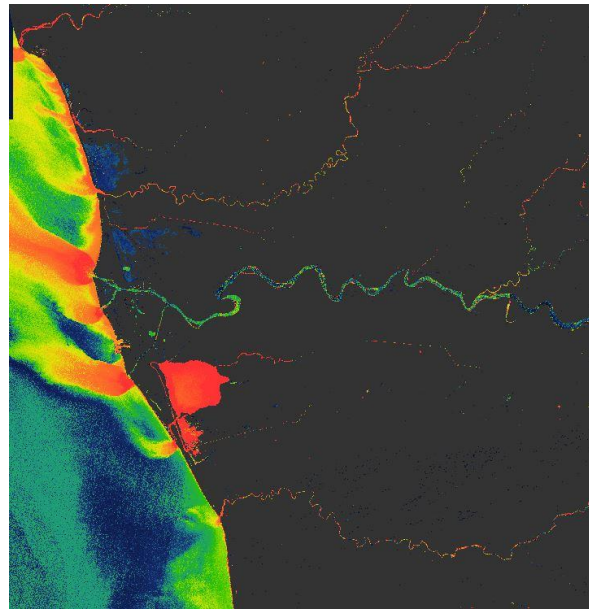
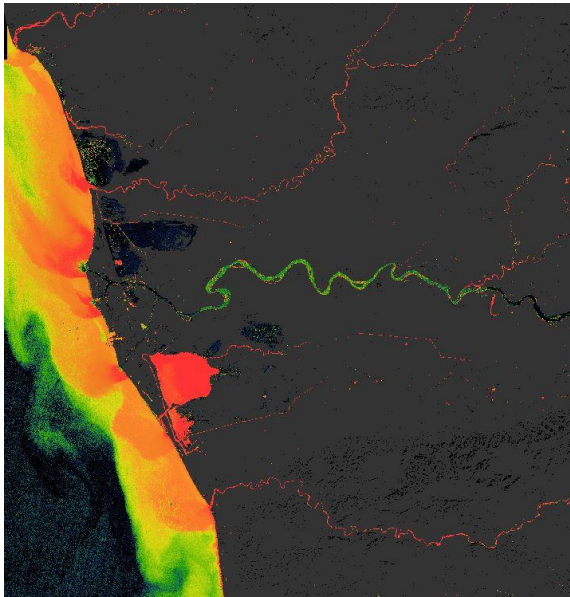

Oxygen Concentration

Georgia
Measurements Data

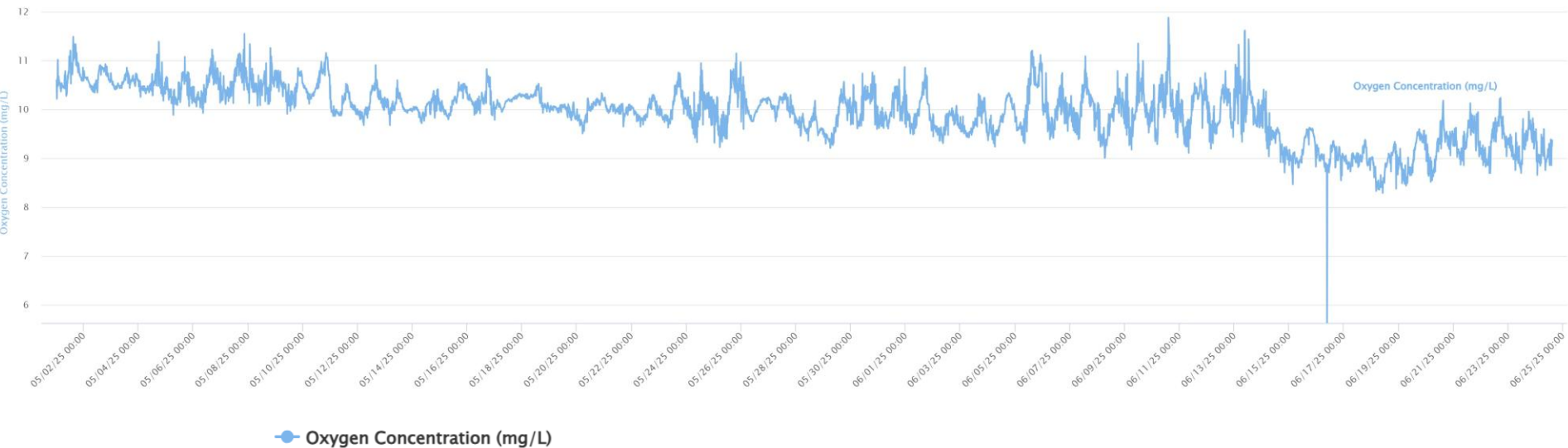

05/01/25 00:00 - 06/24/25 14:30
 05/01/25 00:00 - 06/24/25 14:30

Oxygen Concentration (mg/L)

Y Axis Values:

Minimum value = 5.62 | Maximum value = 11.87 | Average value = 9.94

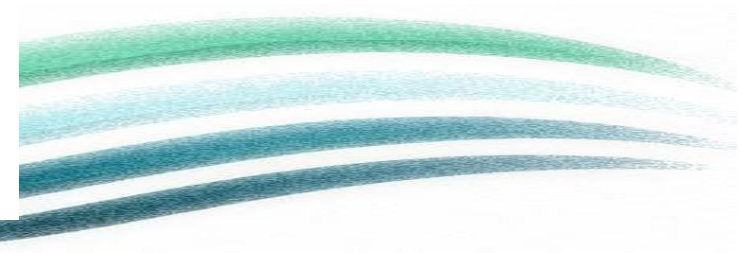



- An average near 10 mg/L is generally good for aquatic life.
- The minimum of **5.62 mg/L** is approaching levels that may stress some sensitive species, especially during night or early morning when photosynthesis ceases.
- The maximum aligns with the high oxygen saturation levels, likely caused by photosynthetic activity (algal blooms indicated by chlorophyll-a data).



Turbidity

Georgia

Measurements Data

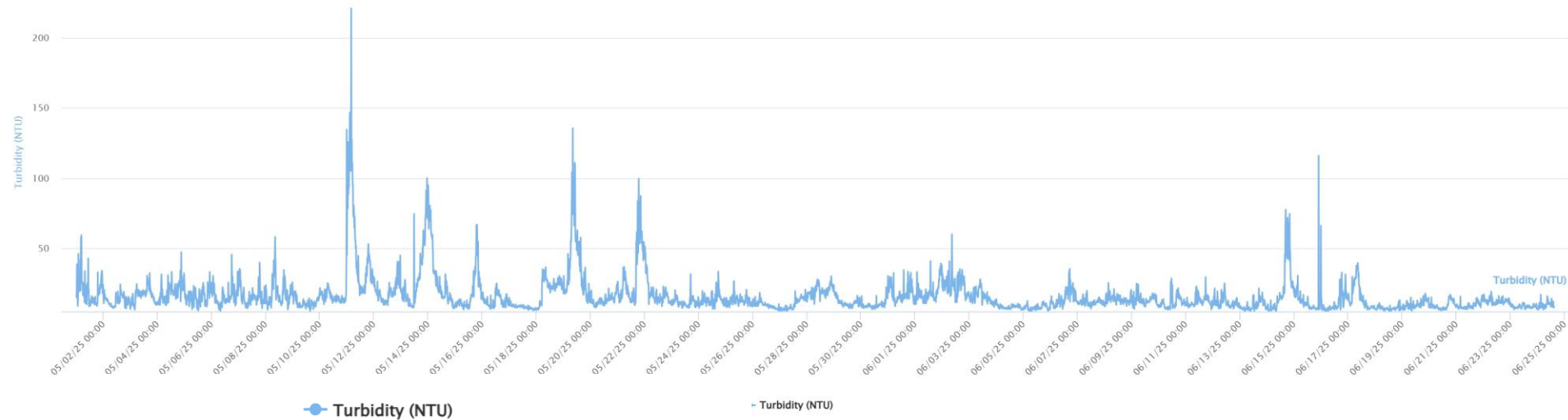

05/01/25 00:00 - 06/24/25 14:30

05/01/25 00:00 - 06/24/25 14:30

Turbidity (NTU)

Y Axis Values:

4.65 220.97

Submit

Minimum value = 4.65 | Maximum value = 220.97 | Average value = 15.62

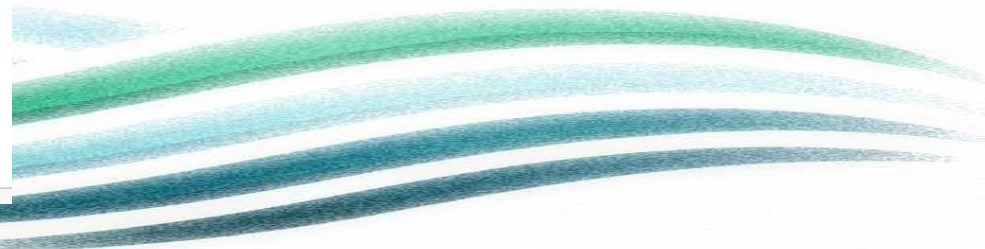

Turbid water are a quite frequent phenomenon in coastal waters, in particular in shallow soft bottom coasts and at the mouths of rivers and estuaries.

Turbidity is caused by small particles in the water, ranging from half a micron to several millimeters, some of mineral composition, such as clay minerals, and others of organic origin.

All these particles can be summarised under the term Suspended Particulate Matter (SPM).





Conductivity

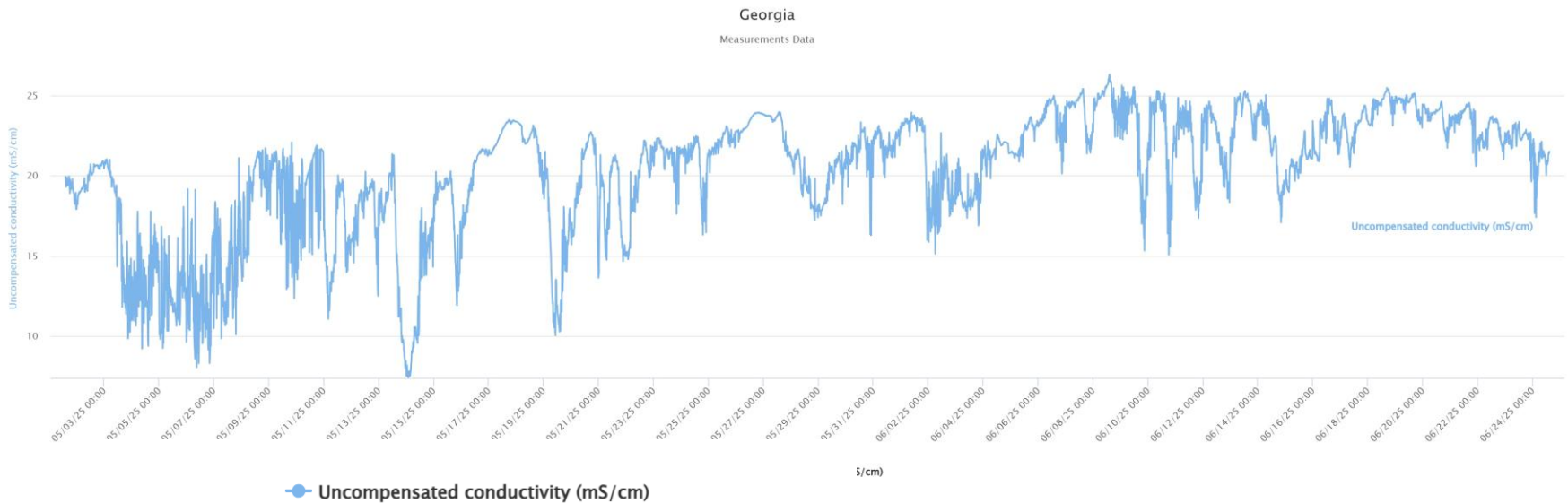

05/01/25 14:00 - 06/24/25 14:30

05/01/25 14:00 - 06/24/25 14:30

Uncompensated conductivity (mS/cm)

Y Axis Values:

Minimum value = 7.37 | Maximum value = 26.32 | Average value = 20.32

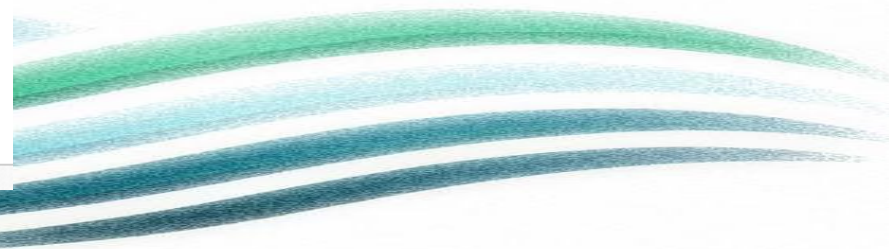



NEXT Black Sea Basin

Uncompensated conductivity (mS/cm)

05/01/25 14:00 - 06/24/25 14:30

05/01/25 14:00 - 06/24/25 14:30

Uncompensated conductivity (mS/cm)

Y Axis Values:

7.37

26.32

Submit

Minimum value = 7.37 | Maximum value = 26.32 | Average value = 20.32

- These values are quite low, suggesting very low ionic concentration—typical for freshwater bodies with minimal pollution or mineral input.



NEXT Black Sea Basin

Georgia

Measurements Data

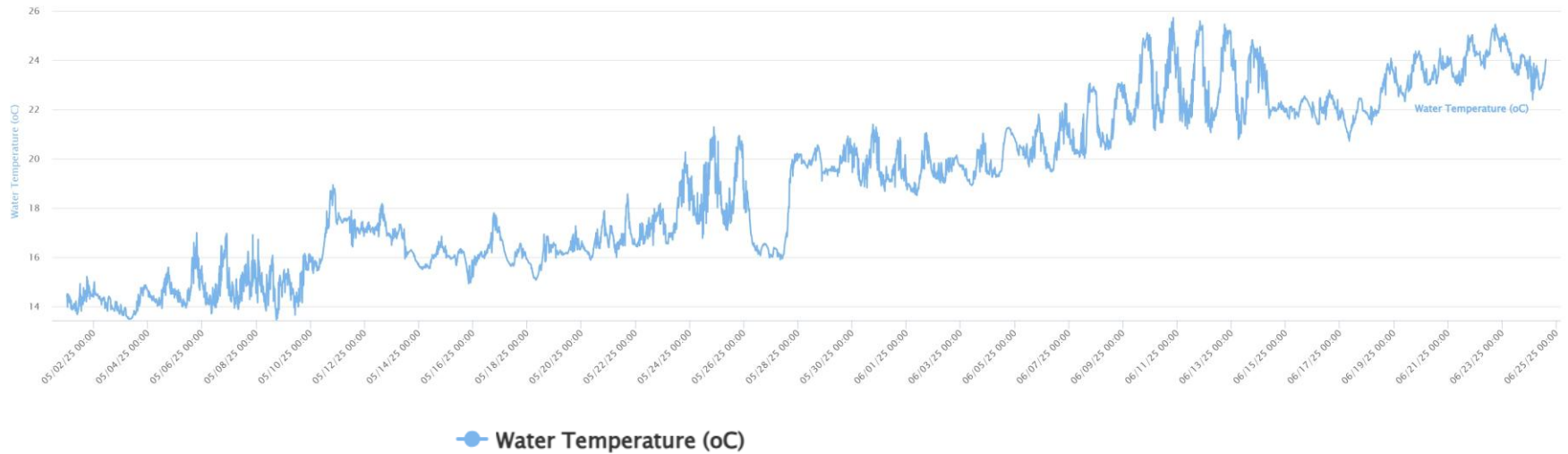

05/01/25 00:00 - 06/24/25 14:30

05/01/25 00:00 - 06/24/25 14:30

Water Temperature (oC)

Y Axis Values:

13.42

25.71

Submit

Minimum value = **13.42** | Maximum value = **25.71** | Average value = **19.01**



Temperature (° C)

Range: 13.43 – 25.71
Average: 19.00

Conductivity (µS/cm)

Range: 7.37 – 26.32
Average: 20.32

Turbidity (NTU)

Range: 4.65 – 220.97
Average: 15.62

Chlorophyll-a (ppb)

Range: 3 – 10,684
Average: 3,516.08

Oxygen Concentration (mg/L)

Range: 5.62 – 11.87
Average: 9.94

Oxygen Saturation (%)

Range: 63.63 – 136.26
Average: 106.05

- ❖ The high chlorophyll-a concentrations and oxygen supersaturation strongly indicate the presence of eutrophic conditions and algal blooms.
- ❖ Turbidity spikes likely result from biological blooms and/or episodic sediment inputs.
- ❖ Periods of oxygen deficiency (minimum 63.63% saturation) suggest that while photosynthesis boosts oxygen during the day, decomposition or respiration processes reduce oxygen at night.
- ❖ Temperature patterns support seasonal biological activity, with warmer conditions likely intensifying algal blooms.
- ❖ Low conductivity points to limited salt or pollutant inflow, suggesting blooms are primarily nutrient-driven rather than due to urban or industrial discharges.

Interreg



Co-funded by
the European Union



NEXT Black Sea Basin

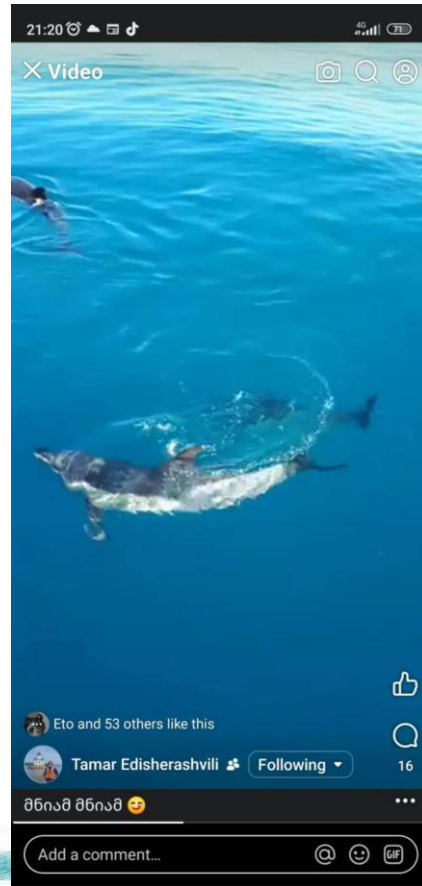

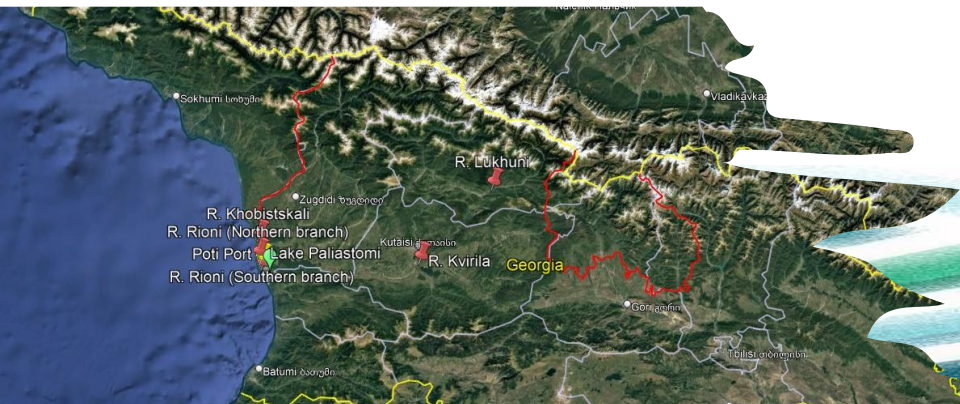
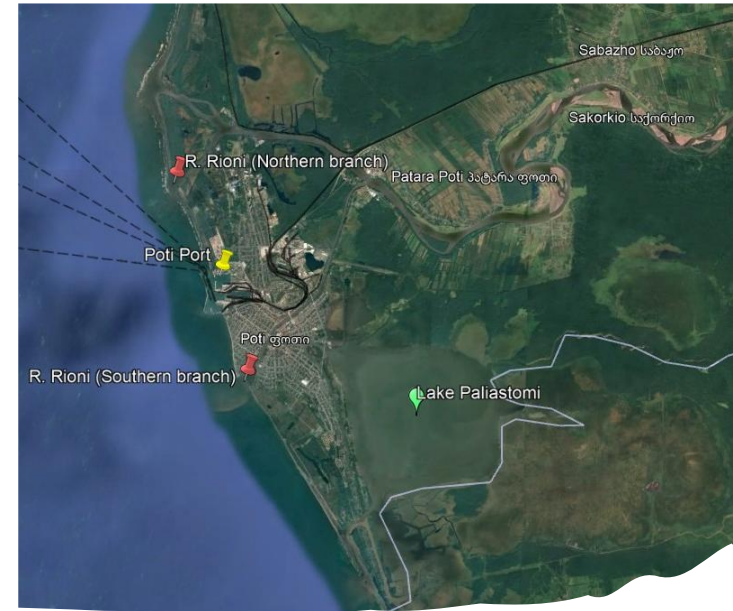
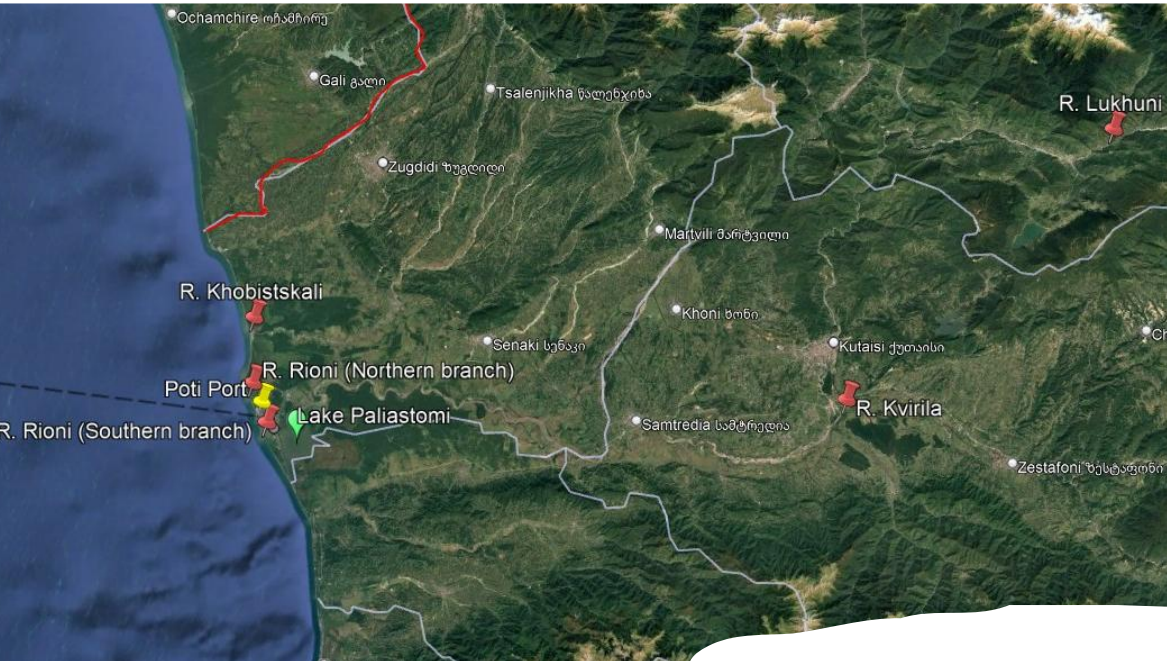

Some sources of water
pollution in Black sea water

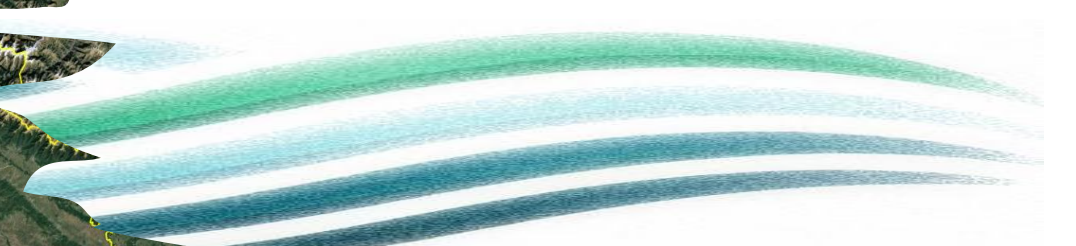

RECOMMENDATION

- **Nutrient Monitoring:** Regular testing of nitrogen and phosphorus to assess eutrophication sources.
- **Algal Bloom Surveillance:** Monitor for harmful algal species, particularly during peak chlorophyll periods.
- **Diel Oxygen Studies:** Investigate day-night oxygen cycles to quantify hypoxia risk.
- **Management Actions:** Consider mitigation strategies to reduce nutrient inputs if bloom intensity poses ecological or health risks.

Interreg



Co-funded by
the European Union



NEXT Black Sea Basin



THANK YOU FOR YOUR ATTANTION

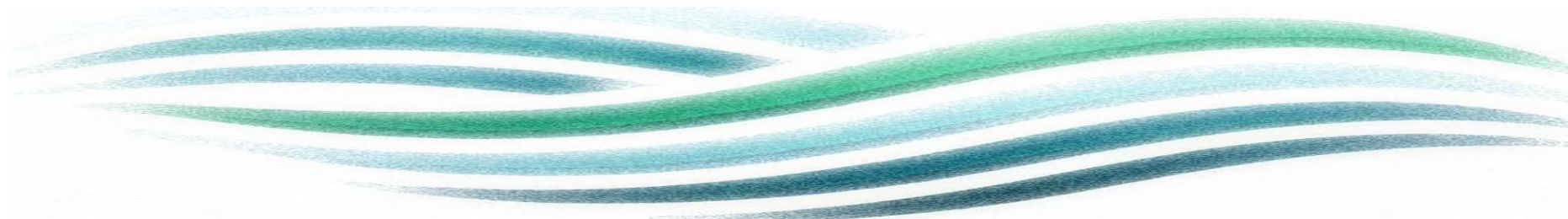

Interreg



Co-funded by
the European Union

NEXT Black Sea Basin



ROV Data in Türkiye & Assessment of benthic habitat «Non-destructive» METHODOLOGY

Yelda AKTAN, Benal GÜL, Cumhur H. YARDIMCI
Istanbul University
Türkiye

EfxINNOs Instrumentation Training Workshop on AUV use, data collection and data processing
Fisheries Research Institute Nea Peramos, Kavala, Greece
July 2-4, 2025,

STUDY SITE

Specific Areas on the Turkish BS Coastal Zone

1. Çilingöz Natural Park-Kumköy (*west of Bosphorus*)
2. Riva-Cebeci (*east of Bosphorus*)
3. Bosphorus Strait

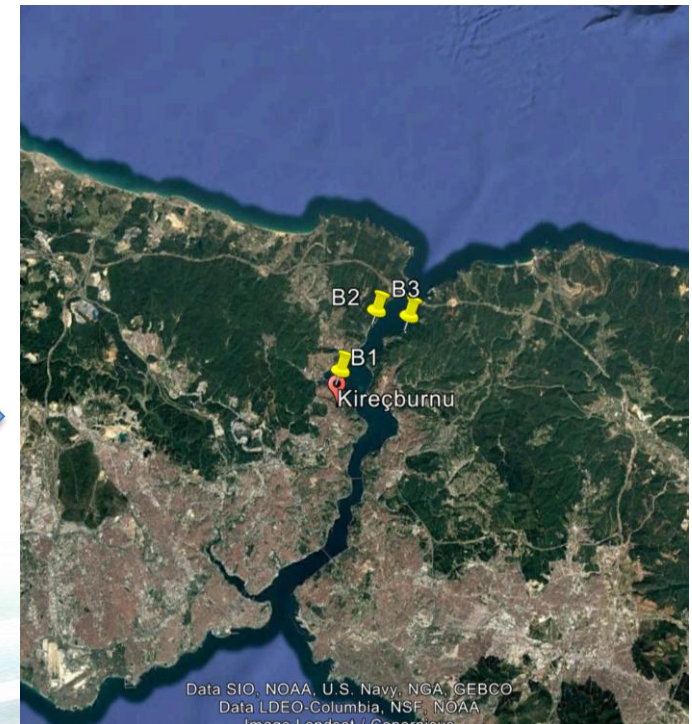

FIELD STUDY

For each site:

- **Acquisition of aerial imageries from Google Earth Pro.**
- **Determination of the pilot sites due to the presence of macrophytic communities.**
- **Monitoring the critical habitats & marine litter:**
Capturing the photogrammetric imagery by manta-towing the ROV
- **Groundtruthing the optical methods with georeferenced diving:**
Detect the outlines of macrophytic communities by GPS coordinates.
- **Estimation of macrophytic cover (%):**
X replicated photoquadratic vertical projection (20x20 cm) in a standart depth.

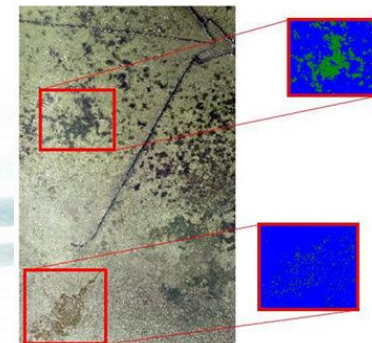
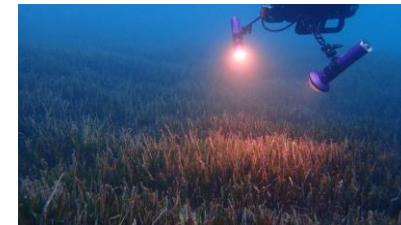

DATA PROCESSING

For each site:

- Assessment of phytobenthic composition from the ROV imageries.
- Integration of collected data (aerial, photogrammetric, diving coordinates) to ArcGIS.
- Evaluation of the relations between the ecological status of phytobenthic communities (EEI) and the anthropization level (LUSI).

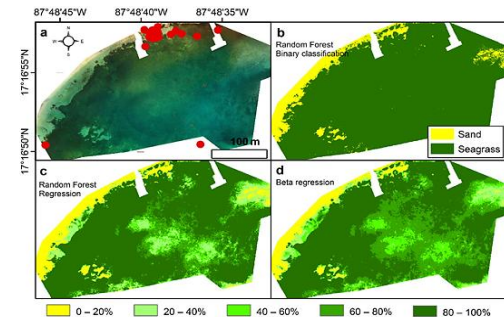

EEI	EQR	Status
$10 \geq EEI > 8$	$1 \geq EQR > 0.75$	High
$8 \geq EEI > 6$	$0.75 \geq EQR > 0.5$	Good
$6 \geq EEI > 4$	$0.5 \geq EQR > 0.25$	Moderate
$4 \geq EEI > 2$	$0.25 \geq EQR > 0$	Low
2	0	Bad

NEXT Black Sea Basin

Data processing

- Human impacts will be reported using the Land Uses Simplified Index (LUSI)
- For each site, % of land use (urban, agricultural, industrial) will be calculated within 1.5 km from the coastline.
- Land uses scores will be used in the formula below to calculate LUSI.

ID	Site	Urban (% landuse)	Agricultural (% landuse)	Industrial (% landuse)	Riverine (mean salinity)	Coastline morphology
1	Name	80	20	0	36.0	Straight
3						
4						
5						

Urban (% landuse)	Agricultural (% landuse)	Industrial (% landuse)	Riverine (mean salinity)	Score	Coastline morphology	Correction factor
< 10 %	< 10 %	> 10 %	> 37.5	0	Concave	1,25
< 33 %	10 – 40 %	> 10 %	34.5 - 37.5	1	Convex	0,75
33 - 66 %	> 40 %		< 34.5	2	Straight	1
> 66 %				3		

LUSI = (urban score + agricultural score + industrial score + riverine score) × coastline correction factor

Calculation of the Ecological Evaluation Index (EEI) after sorting and estimating the cover ecological status groups (ESGs) (Orfanidis et al. 2003).

Methodology

EEI	EQR EEI	Status
10 ≥ EEI > 8	1 ≥ EQR > 0.75	High
8 ≥ EEI > 6	0.75 ≥ EQR > 0.5	Good
6 ≥ EEI > 4	0.5 ≥ EQR > 0.25	Moderate
4 ≥ EEI > 2	0.25 ≥ EQR > 0	Low
2	0	Bad

Data processing

- Ecological evaluation index (EEI) (Orfanidis et al. 2003) will be calculated.
- In order to calculate the EEI, the ecological status gradients (ESG) of benthic macrophytes will be sorted to ESG I and ESG II groups.

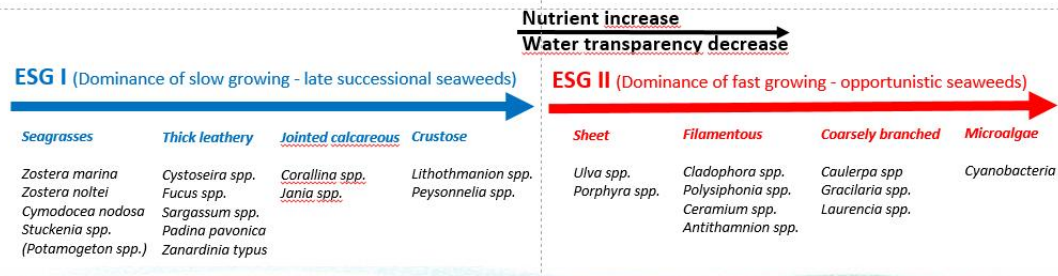

Functional characteristics of marine benthic macrophytes

Ecological State Group	Functional form group	Morphology	Longevity (Succession)	Genera
ESG II	A. Sheet	Foliose	Annual (Opportunistic)	<i>Ulva</i> , <i>Enteromorpha</i> , <i>Dictyota</i> , <i>Scytosiphon</i>
ESG II	B. Filamentous	Delicately branched	Annual (Opportunistic)	<i>Chaetomorpha</i> , <i>Cladophora</i> , <i>Polysiphonia</i> , <i>Ceramium</i> , <i>Spyridia</i>
ESG II	C. Coarsely Branched	Coarsely branched upright	Annual (Mid-successional)	<i>Acanthophora</i> , <i>Caulerpa</i> , <i>Chordaria</i> , <i>Gracilaria</i> , <i>Laurencia</i> , <i>Liagora</i>
ESG I	D. Thick Leathery	Thick blades and branches	Perennial (Late-successional)	<i>Cystoseira</i> , <i>Chondrus</i> , <i>Fucus</i> , <i>Laminaria</i> , <i>Padina</i> , <i>Sargassum</i> , <i>Udotea</i>
ESG I	E. Jointed Calcareous	Articulated calcareous upright	Perennial (Late-successional)	<i>Amphiroa</i> , <i>Corallina</i> , <i>Halimeda</i> , <i>Galaxaura</i> , <i>Jania</i>
ESG I	F. Crustose	Epilithic prostrate encrusting	Perennial (Late-successional)	<i>Hydrolithon</i> , <i>Lithothamnion</i> , <i>Peysonnelia</i>
ESG I	G. Seagrass	Differentiated from foliose to cylindrical	Perennial (Pioneers to late-successional)	<i>Cymodocea</i> , <i>Posidonia</i> , <i>Ruppia</i> , <i>Zostera</i>



NEXT Black Sea Basin

	A	B	C	D	E	F	G	H	I	J	K	L	M	N
1	Genus	ESG	Cover on quadrat (%)											
2	Acetabularia	I												
3	Acanthophora	II												
4	Amphiroa	I												
5	Anadyomene	I												
6	Antithamnion	II												
7	Bryopsis	II												
8	Calithamnion	II												
9	Caulerpa	II												
10	Ceramium	II												
11	Chaetomorpha	II												
12	Champia	II												
13	Chondria	II												
14	Cladophora	II												
15	Codium	II												
16	Colpomenia	II												
17	Corallina	I												
18	Cystoseira	I												
19	Dasya	II												
20	Dermatolithon	I												
21	Dictyopteris	II												
22	Dictyota	II												
23	Ectocarpus	II												
24	Enteromorpha	II												
25	Erithrotrichia	II												
26	Flabellia	I												

ROV (Remotely Operated Vehicle)

GENERAL SPECIFICATIONS

Width : 560 mm

Length : 324 mm

Weight (in air) : 21 kg

Body Material : Anodized Machined Aluminum,
POM, & Buoyancy Foam

Window Material : Acrylic

Depth Rating : 500 m

Operating Temp : -10 to 50 °C

ROV Electrical System

Battery Voltage : 14.8 v 250 Wh Li-ion

Battery Run Time : 2 - 3 Hours (30-sec Battery Change)

Thruster Control : 100% Reversible

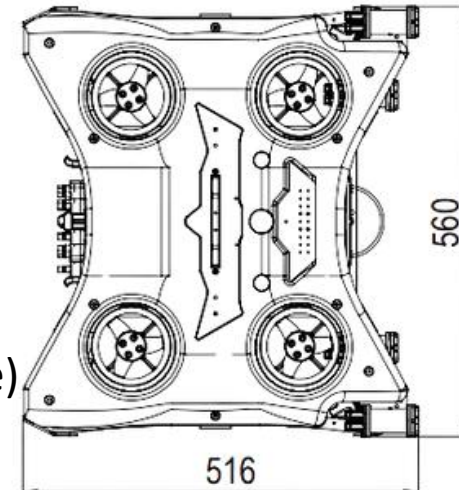
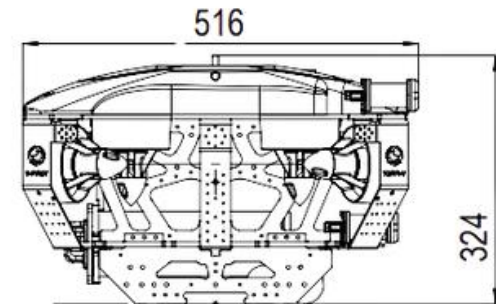



SONAR SYSTEMS

Sonoptix ECHO Multibeam Sonar
The Oculus M-Series Multibeam Sonar
Cerulean Omniscan450

NAVIGATION

The SeaTrac USBL
WaterLinked Underwater GPS G2
Cerulean Mark III ROV Locator
WaterLinked A50 & 125

AUXILLARY CAMERA

DVL Low Light Camera
4k Camera Optic ZOOM

MANIPULATORS&TOOLS

Newton Gripper
Reach Robotics Manipulators
Sediment Sampler
Swappable Jaws

ADDITIONAL SENSORS

Altimeter
Dissolved Oxygen
pH Sensors & ORP Sensors

Interreg



Co-funded by
the European Union



NEXT Black Sea Basin



Interreg



Co-funded by
the European Union



NEXT Black Sea Basin

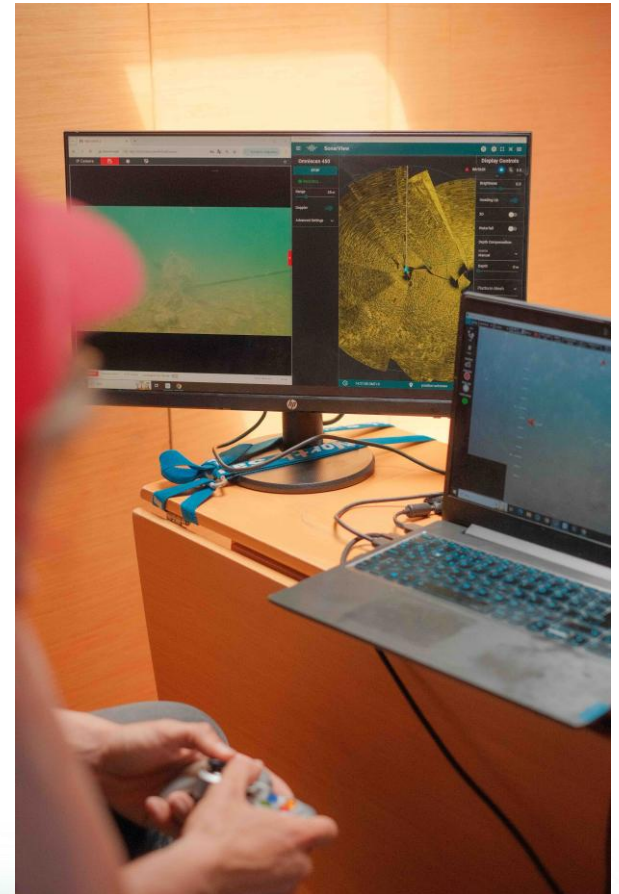



NEXT Black Sea Basin

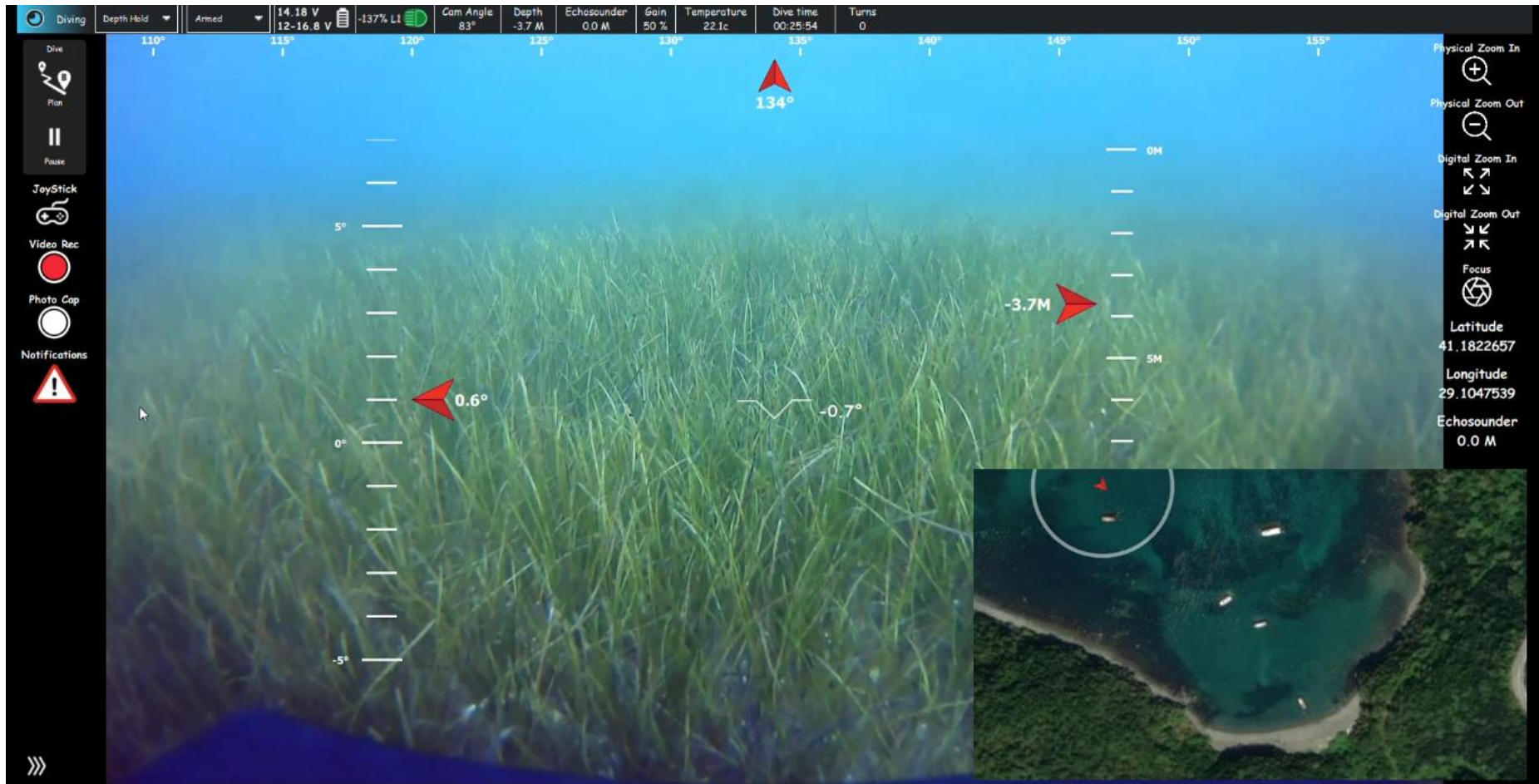



EMODnet

European Marine
Observation and
Data Network

Data Ingestion



How can Research Projects arrange inclusion of new marine data into EMODnet

Dick Schaap - MARIS
coordinator EMODnet Ingestion

EfxINNOs project

European Marine Observation and Data Network (EMODnet)

- EMODnet was initiated by EU DG MARE in 2009
- Focus on **European data products and services** in support of Blue Economy, Blue Environment and Marine Knowledge
- **Seven thematic groups and an ingestion service**
- EMODnet is the **EU in-situ data service**, next to Copernicus Marine for forecasts and satellite data

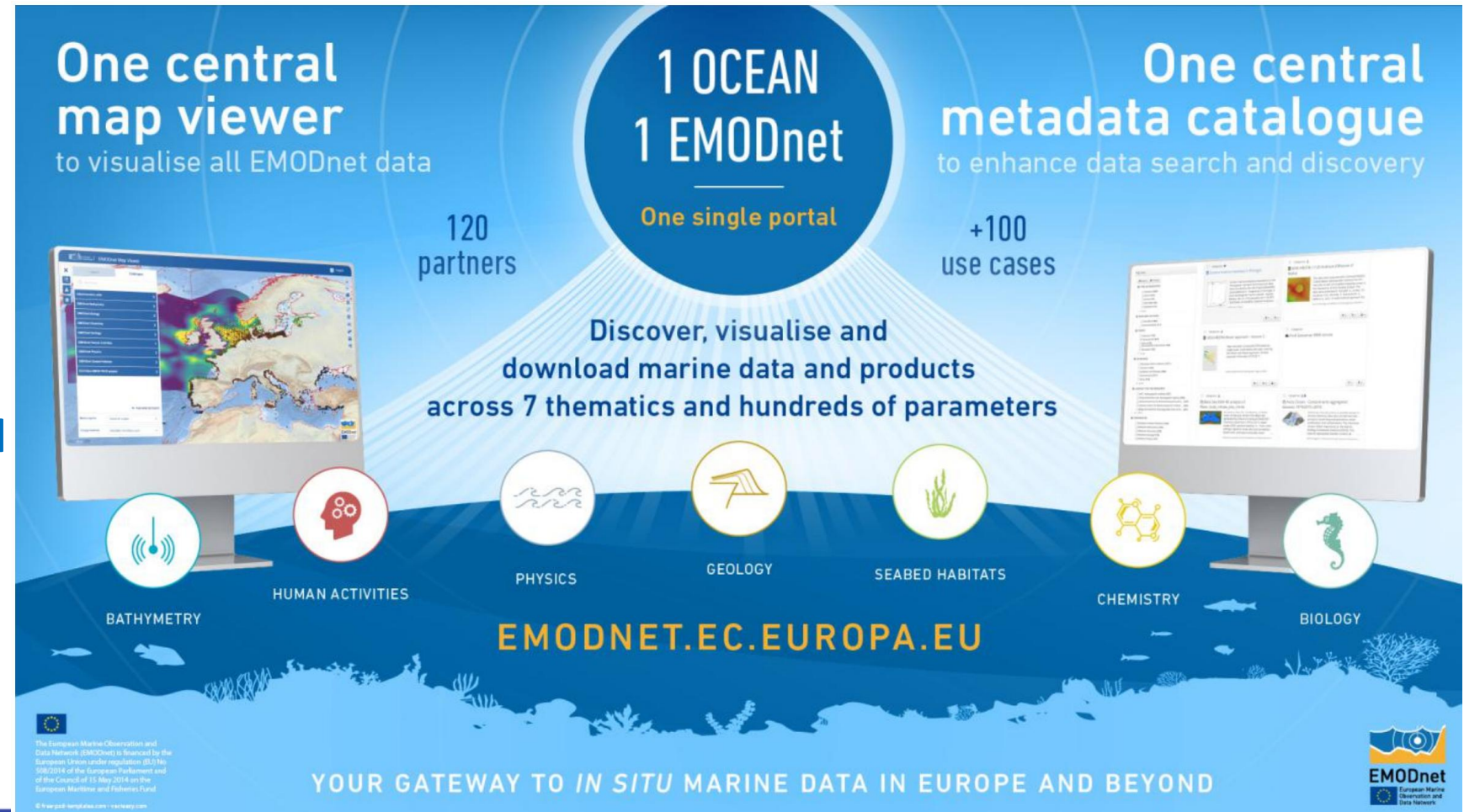

One central map viewer
to visualise all EMODnet data

**1 OCEAN
1 EMODnet**
One single portal

One central metadata catalogue
to enhance data search and discovery

120 partners

+100 use cases

Discover, visualise and download marine data and products across 7 thematic and hundreds of parameters

BATHYMETRY HUMAN ACTIVITIES PHYSICS GEOLOGY SEABED HABITATS CHEMISTRY BIOLOGY

EMODNET.EC.EUROPA.EU

YOUR GATEWAY TO *IN SITU* MARINE DATA IN EUROPE AND BEYOND

The European Marine Observation and Data Network (EMODnet) is financed by the European Union under regulation (EU) No 1042/2014 of the European Parliament and of the Council of 15 May 2014 on the European Maritime and Fisheries Fund.

<https://emodnet.ec.europa.eu/en>

EMODnet: Unlocking and democratising marine data, information and knowledge: Open and free for all

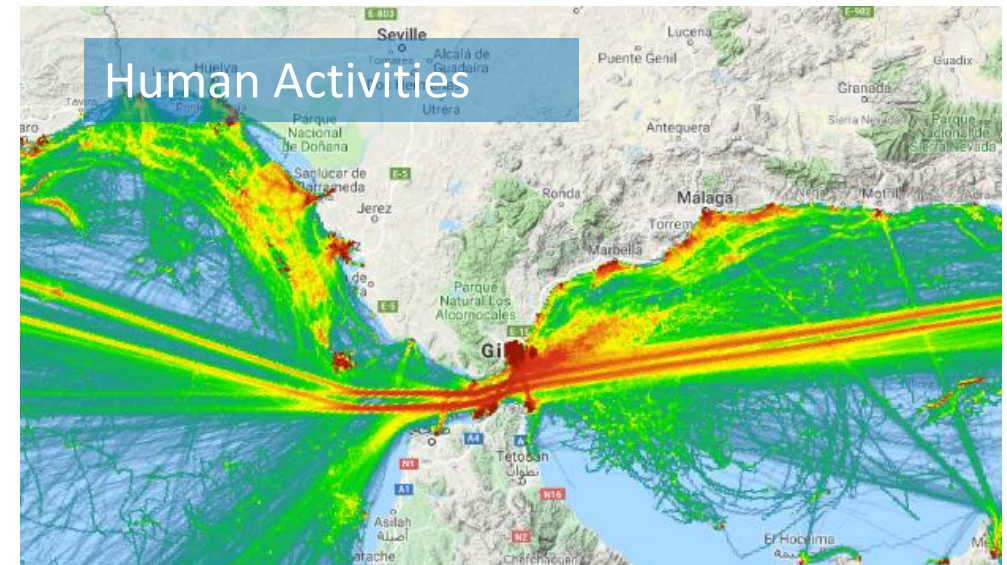
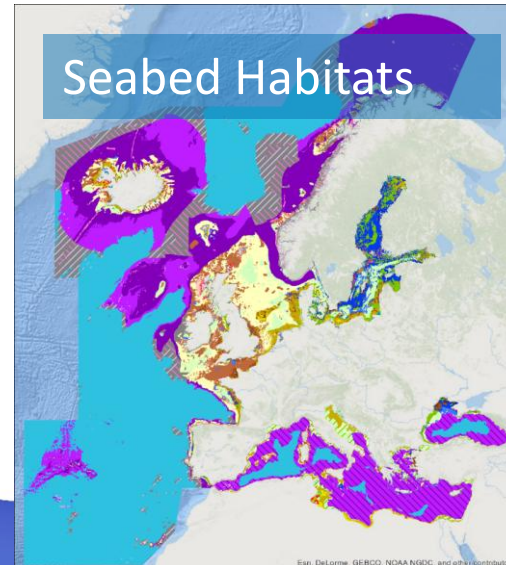
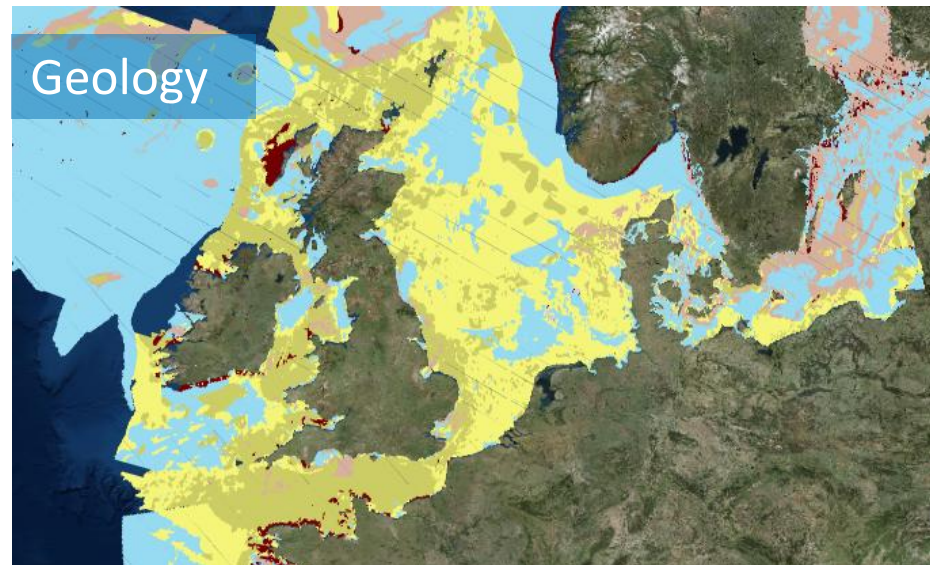
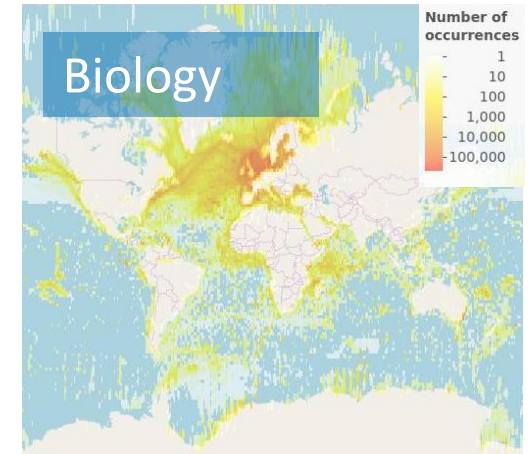
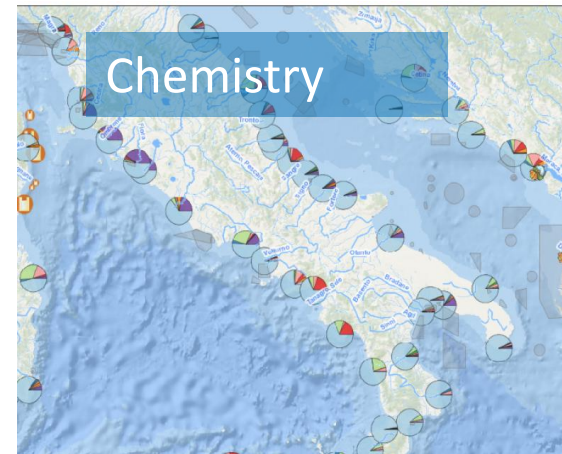
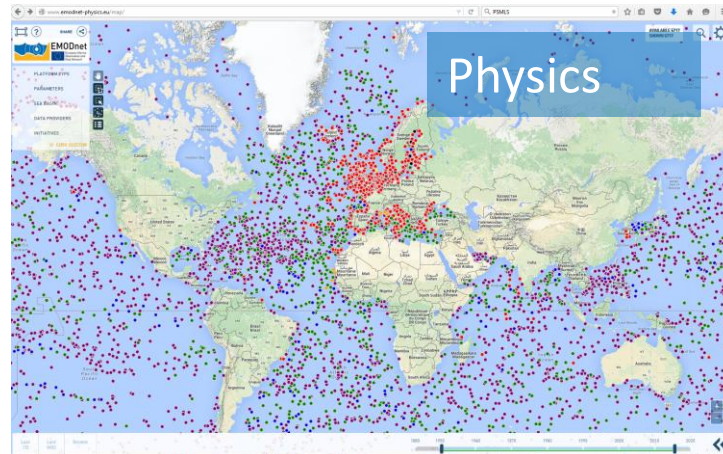
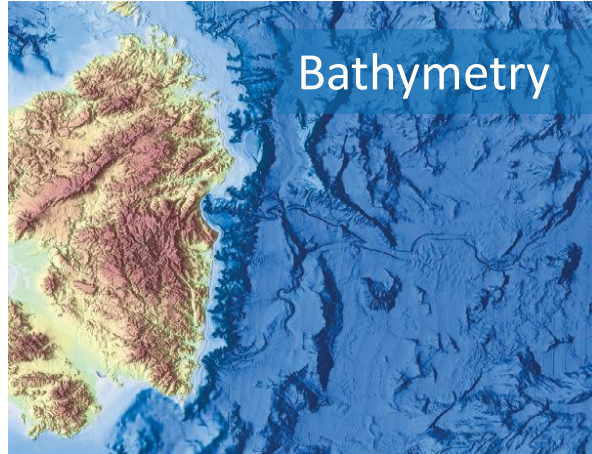

Value of EMODnet for EU Research and Innovation Projects



- EMODnet **provides open and free** baseline pan-European marine data and data products that can be used in **R&I activities** towards a better understanding of the ocean environment, ocean applications, conservation and management.
- See the EMODnet portal for **use cases & data sharing success stories**
- **Horizon Europe Projects**, collecting *in situ* marine environmental and/or human activities data, have a **contractual obligation** to make their data available via open access.
- The EC aims to streamline this through **EMODnet, as its in-situ data service**.
- Contributing to EMODnet will facilitate R&I projects to make their data compliant to **FAIRness principles**
- Moreover, R&I projects and researchers get **wider recognition** by acknowledgement in EMODnet products and by wider use of their data.
- Finally, it contributes to **extending the reach** of their work, as EMODnet is feeding into larger initiatives such as the EU Digital Twin of the Oceans (EDITO) and global UN Ocean Decade.

EMODnet interacts with data infrastructures and networks for getting FAIR data

- The **EMODnet Thematic groups** rely and interact with European marine data infrastructures such as **SeaDataNet**, **EurOBIS**, **EGDI**, **ICES**, and others.
- These infrastructures have established nodes in many European countries.
- Their data centres offer validation, long term stewardship, and FAIR documentation, following agreed community standards.
- Many are members of **EMODnet Ingestion**

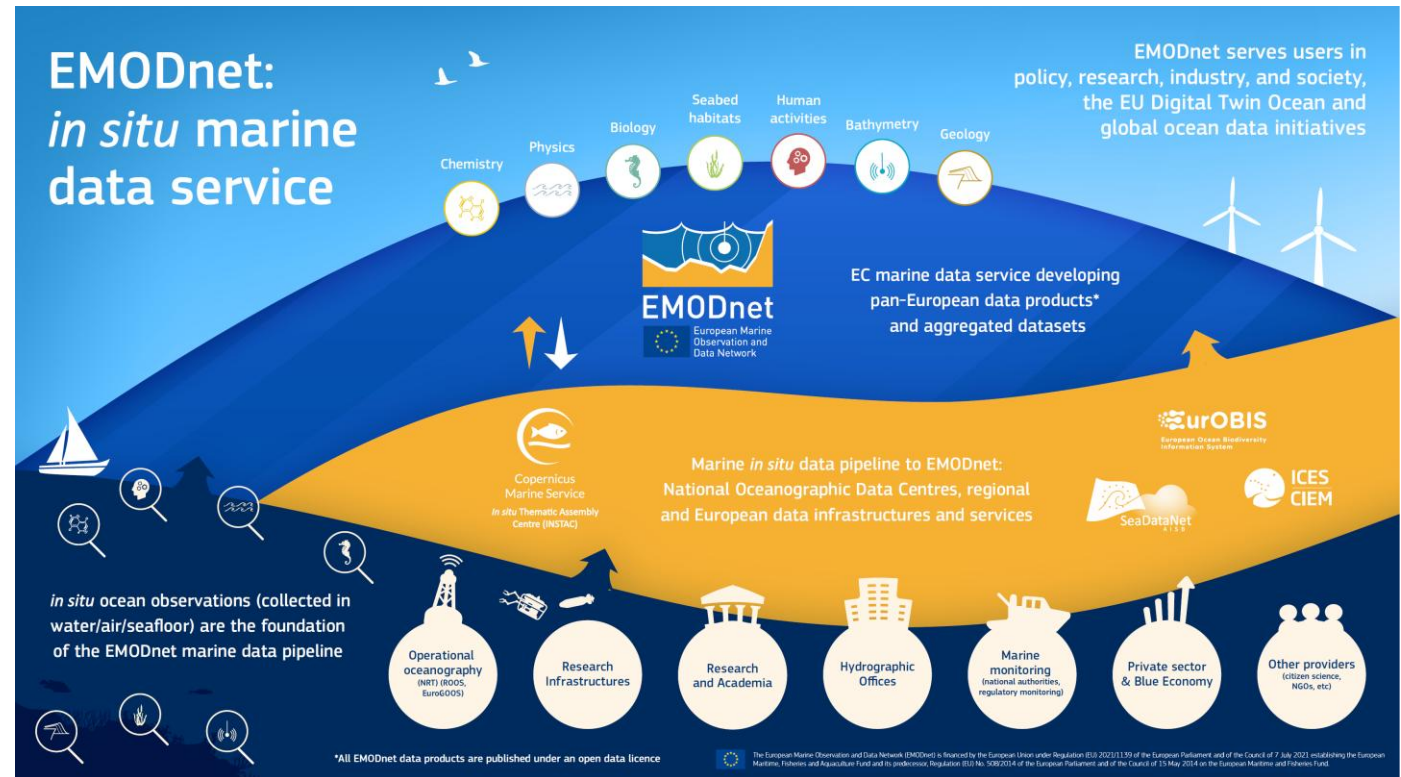

EMODnet Data Ingestion services

A free and open EU service to all for submission and sharing of marine data

- **Data Submission service for delayed mode datasets**

following ISO 19115-2 standard, compliant with the INSPIRE model

- **Discovery and Access service**

publishing completed submissions as-is and elaborated

- **Services for integrating operational data**

together with EMODnet Physics

- **Guidelines**

Standards, tools, and services for different data types

- **Large network of expert data centres**

Giving guidance and support for DMPs and adopting standards

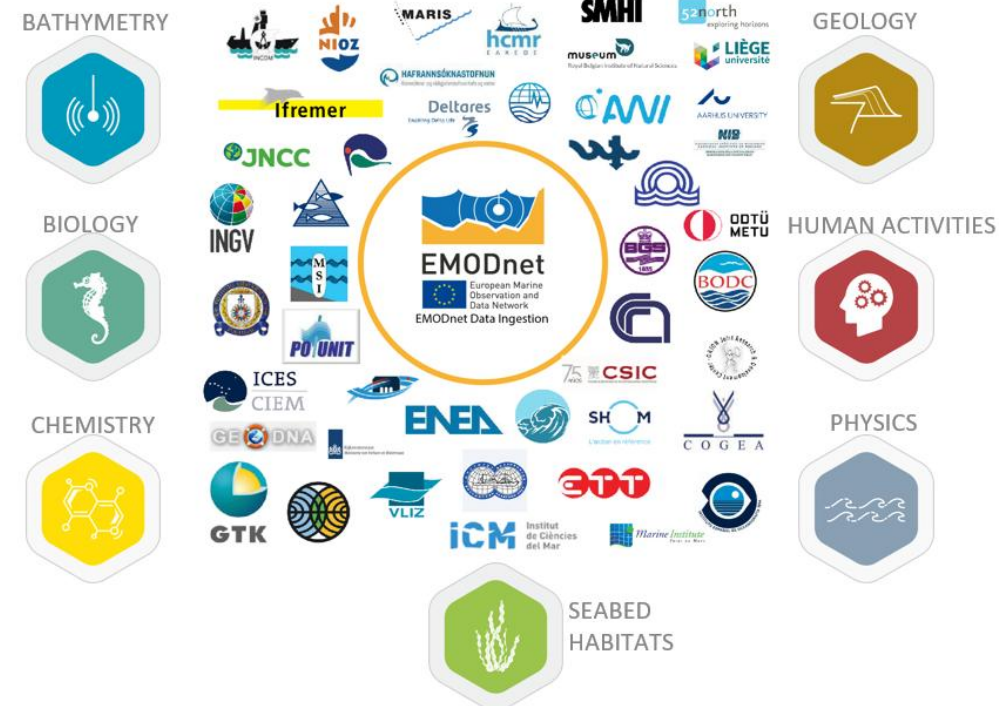

Network of 50 Data Centres, specialized marine centres, and all EMODnet thematic coordinators

<https://emodnet.ec.europa.eu/data-ingestion>

Recommendations to EU R&I projects

- EU R&I projects should initiate, formulate, and deploy DMPs **themselves**, taking into account their research and data collection plans, and considering the community standards and practices as promoted and used by EMODnet.
- They can seek **support** from EMODnet Ingestion for reviewing their DMPs, before these are published and deployed, and for possible matchmaking with relevant data centres.
- The **data submission service** of EMODnet Ingestion can be used for transfer, **albeit** for well documented and formatted metadata and data sets, following the guidelines as posted on the **EMODnet portal**.
- EMODnet Ingestion could also assist for sharing **operational data streams** with the EMODnet operational oceanography data exchange.



EMODnet
European Marine
Observation and
Data Network

EMODnet for Horizon Europe and EU Mission Restore our Ocean and Waters: Guidelines for European project data submissions

Marine data as valuable assets:

Data from the marine environment are a valuable asset. Rapid access to reliable and accurate marine data and information is vital in addressing threats to the marine environment, in the development of policies and legislation to protect vulnerable areas of our coasts and oceans, in supporting research with the evidence-base to understand the complexity of marine ecosystems, trends, and in forecasting future changes. Likewise, better quality and more easily accessible marine data is a prerequisite for further sustainable economic development, so-called 'blue growth', and to achieve the ambitious targets of the EU Green Deal and EU Mission: Restore our Ocean and Waters.

EMODnet:

The European Marine Observation and Data Network (EMODnet) is an established European Commission *in situ* marine data service, and a flagship initiative funded by EC DG MARE. Complementary to Copernicus Marine, EMODnet is one of the main Marine Knowledge Initiatives of the European Union. Through its Portal (<https://emodnet.ec.europa.eu/en>) EMODnet provides access to European marine data across seven discipline-based themes and its Ingestion service:

Bathymetry	Biology	Chemistry	Geology
			
Data and maps on bathymetry (water depth), and coastlines, e.g., Digital Terrain Model	Data and maps on temporal and spatial distribution of species abundance and biomass from several taxa.	Data and maps on the concentration of nutrients, organic matter, contaminants, and marine litter in water, sediment and biota.	Data and maps on seabed substrate, sea-floor geology, coastal behaviour, geological events, minerals, and submerged

EMODnet for Horizon Europe and EU Mission Restore our Ocean and Waters: Guidelines for European project data submissions

Guidelines for different data types

- At the EMODnet website you can find more details about EMODnet Ingestion, including guidance for Research Projects about these common standards.
 - <https://emodnet.ec.europa.eu/en/data-ingestion>
 - <https://emodnet.ec.europa.eu/en/data-ingestion#guidelines-for-european-projects-data-submissions>
 - <https://emodnet.ec.europa.eu/en/data-ingestion#guidelines-for-different-data-types>
- EMODnet Ingestion could also assist for sharing **operational data streams** with the EMODnet operational oceanography data exchange:

EfxINNOs project – what to do?

- EfxINNOs aims to use ROV and buoy to map seagrass habitats, seabed marine litter and collect physico-chemical conditions in the Black Sea and the North Aegean Sea. In Bulgaria, Romania and N. Greece use will be made of microAUV equipped with camera and side scan sonar, while in Turkey an ROV and in Georgia a buoy has been deployed.
- **Three data types:**
 - CTD data => interesting for SeaDataNet
 - Seabed Marine Litter => interesting for EMODnet Chemistry
 - Seagrass => interesting for EMODnet Seabed Habitats

EfxINNOs project – what to do: SeaDataNet for physical and chemical data

SeaDataNet: <https://www.seadatanet.org>

PanEuropean data management infrastructure for marine and oceanographic data and provides metadata discovery and data access services to the data holdings of a distributed network of more than 100 connected marine data centres from 35 countries. Specific file have been developed and used for data exchange:

- SeaDataNet Common Data Index (CDI) metadata format
- SeaDataNet ODV4 ASCII data format for profiles, time series and trajectories,
- SeaDataNet NetCDF with CF compliance data format for profiles, time series and trajectories,
- [manuals and guidelines on the data transport formats](#)
- <https://www.seadatanet.org/Standards/Metadata-formats/CDI>
- MIKADO and NEMO tools for formatting:
<https://www.seadatanet.org/Software>

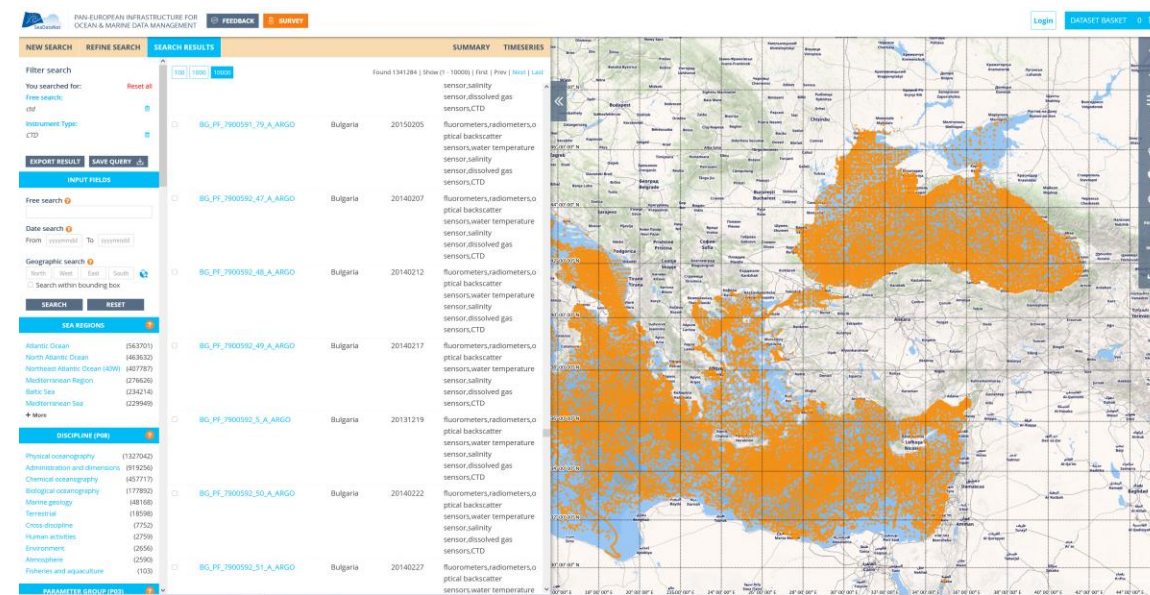

Prepare metadata and data as SeaDataNet and submit via EMODnet Ingestion = Submission service

<https://emodnet.ec.europa.eu/data-ingestion>

EfxINNOs project – what to do: Seabed Marine Litter

EMODnet Chemistry:

<https://emodnet.ec.europa.eu/en/chemistry>

Compiles harmonized data collections for Marine Litter:

- Beach Litter
- Sea Floor Litter
- Micro Litter in sediments and biota

Tools and formats are available at:

<https://emodnet.ec.europa.eu/en/chemistry#marine-litter>

But for Sea Floor Litter we work with data from trawls with nets.

Using videos is under development in international cooperation and European AI projects.

Metadata specifications for videos are well progressing.

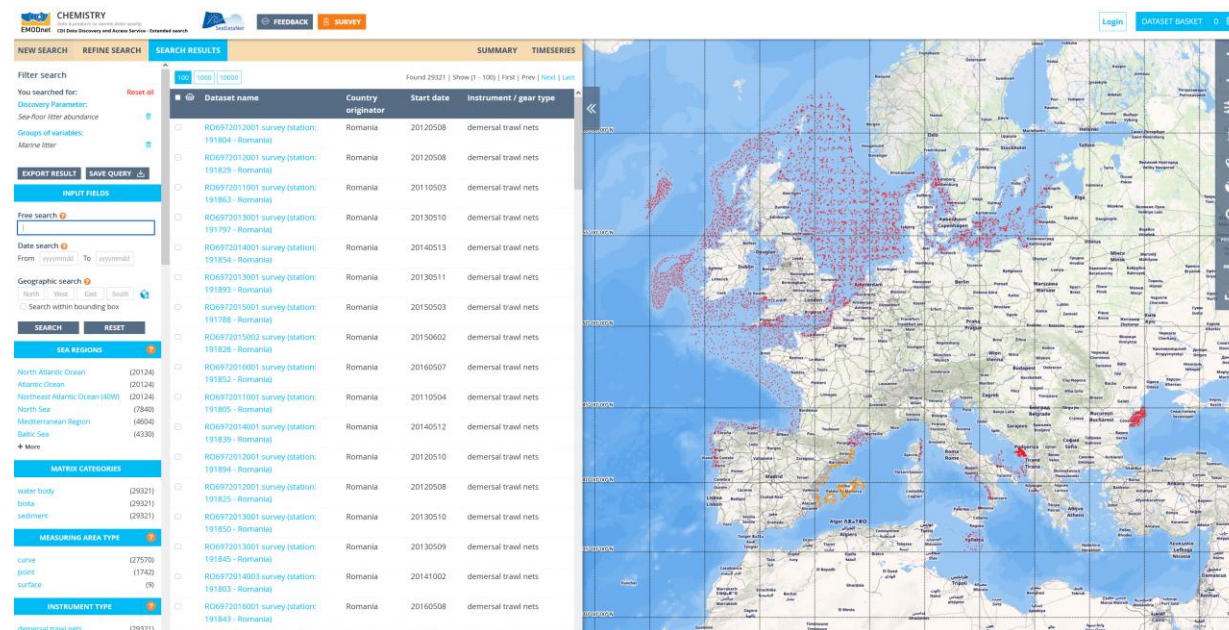

https://cdi-chemistry.seadatanet.org/search/welcome.php?query=3205&query_code={9E139DFB-0605-442F-BE37-D8628479EBCA}

Prepare full documentation on the videos specifying time, place, who, camera details etc and submit via EMODnet Ingestion = Submission service OR else (big data) inform us by email

<https://emodnet.ec.europa.eu/data-ingestion>

EfxINNOs project – what to do: Seabed Marine Litter

EMODnet Chemistry:

<https://emodnet.ec.europa.eu/en/chemistry>

- More about [Sea Floor Litter](#)
- Go to: <https://emodnet.ec.europa.eu/en/chemistry#marine-litter>
- and click on:
- [Sea Floor Data Flow](#) to get more info on formats and classifications:

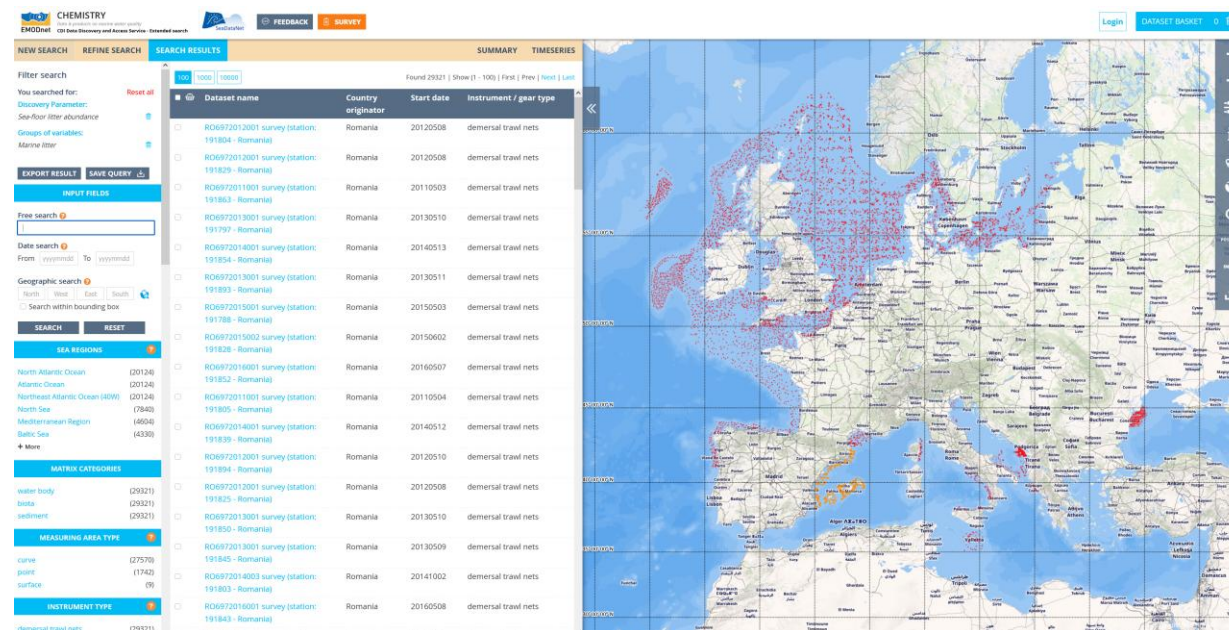

https://cdi-chemistry.seadatanet.org/search/welcome.php?query=3205&query_code={9E139DFB-0605-442F-BE37-D8628479EBCA}

Sea Floor Litter Data-Flow

1. Format Data

- Use the [guidelines and forms](#) for gathering marine litter data;
- Use [Marine Litter Manager tool](#) to format data;
- See [ICES vocabularies](#) and to describes Sea Floor litter data;
- Download some [Example files](#)

2. Validate Data

Use [EMODnet SeaFloor Format Validator](#) to validate data.

3. Send Data

Send the data to info@emodnet-chemistry.eu

<https://emodnet.ec.europa.eu/data-ingestion>

EfxINNOs project – what to do: Seagrass

EMODnet Seabed Habitats:

<https://emodnet.ec.europa.eu/en/seabed-habitats>

Provides access to seabed habitat data in Europe. This includes new products such as the EMODnet broad-scale seabed habitat map for Europe (EUSeaMap) and habitat maps and observations gathered from surveys across Europe.

Tools and formats are available at:

<https://emodnet.ec.europa.eu/en/tools-guidelines>

? If they use videos ?

Contact with **EMODnet Seabed Habitats group** will be useful for better guidance !

Prepare full documentation on the videos specifying time, place, who, camera details etc and submit via EMODnet Ingestion = Submission service OR else (big data) inform us by email

<https://emodnet.ec.europa.eu/data-ingestion>

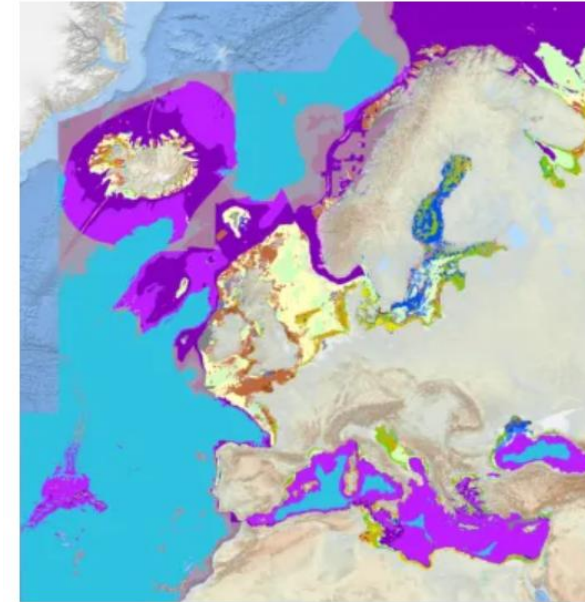

EMODnet Seabed Habitats - Broad-scale seabed habitat map for Europe (EUSeaMap) - 2023



EMODnet



European Marine
Observation and
Data Network



emodnet.ec.europa.eu

Stay up-to-date with
the latest news





EMODnet for Horizon Europe and EU Mission Restore our Ocean and Waters: Guidelines for European project data submissions

Marine data as valuable assets:

Data from the marine environment are a valuable asset. Rapid access to reliable and accurate marine data and information is vital in addressing threats to the marine environment, in the development of policies and legislation to protect vulnerable areas of our coasts and oceans, in supporting research with the evidence-base to understand the complexity of marine ecosystems, trends, and in forecasting future changes. Likewise, better quality and more easily accessible marine data is a prerequisite for further sustainable economic development, so-called 'blue growth', and to achieve the ambitious targets of the EU Green Deal and EU Mission: Restore our Ocean and Waters.

EMODnet:

The European Marine Observation and Data Network (EMODnet)¹ is an established European Commission *in situ* marine data service, and a flagship initiative funded by EC DG MARE. Complementary to Copernicus Marine, EMODnet is one of the main Marine Knowledge Initiatives of the European Union. Through its Portal (<https://emodnet.ec.europa.eu/en>) EMODnet provides access to European marine data across seven discipline-based themes and its Ingestion service:

Bathymetry

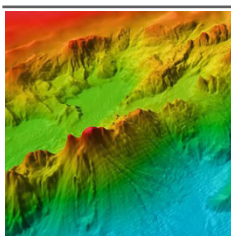

Data and maps on bathymetry (water depth), and coastlines, e.g., Digital Terrain Model

Biology



Data and maps on temporal and spatial distribution of species abundance and biomass from several taxa.

Chemistry

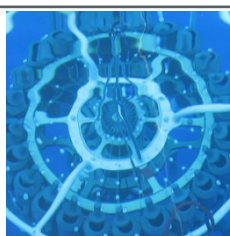

Data and maps on the concentration of nutrients, organic matter, contaminants, and marine litter in water, sediment and biota.

Geology

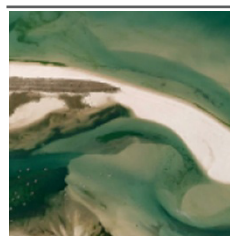

Data and maps on seabed substrate, sea-floor geology, coastal behaviour, geological events, minerals, and submerged landscapes.

¹ emodnet.ec.europa.eu

Human Activities

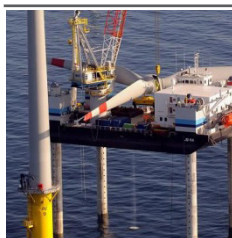

Data and maps on the intensity and spatial extent of human activities at sea, e.g., Vessel Density maps and National Maritime Spatial Planning

Physics

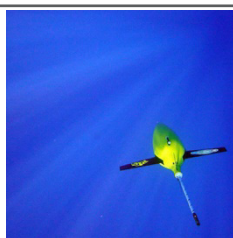

Data and maps on salinity, temperature, waves, winds, currents, sea-level, light attenuation, ice, river outflow, underwater noise.

Seabed Habitats



Data, maps on the spatial distribution and extent of seabed habitats and communities, e.g., EUSeaMap broad-scale seabed habitat map for European seas

Ingestion

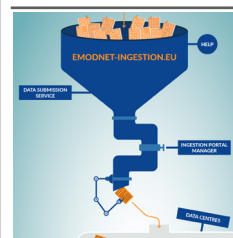

Reaching out to potential new data providers and operating services and support for uptake of their data assets, for ingestion into relevant EMODnet thematics and data/ data products.

Flow of data to EMODnet:

EMODnet is deployed by a network of > 120 organisations that work together on bringing together data and processing these into high-quality and interoperable data layers and data products, that are freely made available to users by a central map viewer, products catalogue, and data sub-setting service, as well as by standard machine-to-machine services. For the data throughput, the EMODnet thematic groups rely on and interact with European marine data infrastructures such as SeaDataNet, EurOBIS, EGDI, ICES, and others. Their data centres offer validation, long term stewardship, and FAIR documentation, following agreed community standards, for data, observed by currently more than a thousand data originators from public, research and private sector in the European marine data landscape. In addition, EMODnet experts create pan-European data products that are fully open and accessible for use e.g., Bathymetry Digital Terrain Model, EUSeaMap broad-scale seabed habitat map for European seas, Vessel Density composite maps, etc.

What is the value of EMODnet for EU Research and Innovation Projects:

Firstly, EMODnet supports research and innovation (R&I) by providing an open and free service for accessing baseline pan-European marine data and data products that can be used to inform and underpin R&I activities towards a better understanding of the ocean environment, ocean applications, conservation and management. Examples of EMODnet's use by EU R&I projects and by wider users is available on the EMODnet Portal².

European research projects that are collecting *in situ* marine environmental and/or human activities data have a contractual obligation to make their data openly available. The EC aims to streamline this through EMODnet, as its in-situ data service. For European projects, contributing to EMODnet will facilitate them to make their data compliant to FAIRness principles, and getting wider recognition by acknowledgement in EMODnet products and by wider use of their data. Furthermore, it will enable them to extend the reach of their work, as EMODnet is feeding into larger initiatives such as the EU Digital Twin Ocean (DTO) and contributing to global efforts like the UN Ocean Decade. Likewise, several of the EMODnet services and products might be useful for the research activities in the European projects as these give access to validated data products and their underpinning data sets.

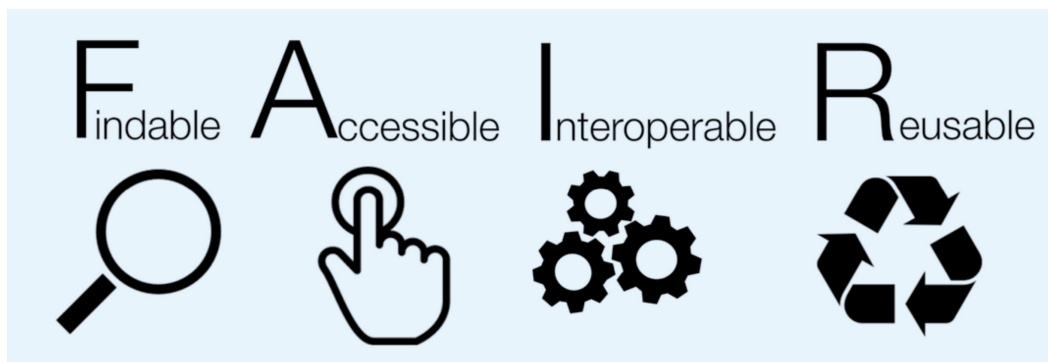

FAIR data principles describe standards of Findability, Accessibility, Interoperability and Reusability. FAIR data are essential for large-scale, machine-driven, multidisciplinary analyses to realize the full scientific and societal value of data.

Marine Data Management Guidelines:

Marine data include a very wide range of measurements and variables derived from a broad spectrum of multidisciplinary research projects and monitoring programmes. Depending on the data type, the acquisition systems, the delivery time frame or operations of the archiving centre, there is not a unique used data model and structure and the original measurement format may not be the same as the format that the archiving centre can accept. However, there are a number of [general principles](#) that should be followed. In addition, it is strongly advised that data submitters adopt the common formats for metadata and data within the existing marine community practices of EMODnet and make use of these [common standards](#) for their data management and exchange towards EMODnet. This will enable the easiest integration of their data sets into the current data systems and make them re-usable.

Connecting operational oceanography stations:

In addition to **delayed mode** data sets and derived products, EMODnet also provides discovery and access to **Near Real Time** data streams from an increasing number of operational observation platforms and networks on a global scale. For this, EMODnet Ingestion works together with EMODnet Physics and Copernicus In-Situ TAC to give support for connecting data output streams from new stations to EMODnet in a [two-stage process](#), going from an easy 'as-is' connection to more elaborated exchange, including adoption of standard metadata formats and possible inclusion of data archives through SeaDataNet. See the joint EMODnet – Copernicus Marine Service communication³ for more information.

Recommendations to EU projects:

The handling and management of large volumes of heterogeneous data generated from different observation-based infrastructures is a key challenge. Users of marine data infrastructures require high-quality FAIR metadata and data. European research projects are recommended:

- » Adopt community standards as in use in EMODnet for formulating **Data Management Plans** (DMP) for handling and documenting data collection and data processing steps in their project to contribute to long-term data preservation and accessibility. This will ultimately allow their data to be FAIR and machine-readable;
- » DMPs should be defined by the goals of a research project or observation program and data should be documented through metadata following the EMODnet community standards;

3 EMODnet and Copernicus Marine Service release joint communication on European *In Situ* Marine Data Service Landscape | European Marine Observation and Data Network (EMODnet) (europa.eu)

- » Design and implement the DMPs in collaboration with marine data management infrastructures and their national nodes that are feeding EMODnet and who provide standards and operate tools for submitting data and metadata, and facilitate long-term data archiving;
- » Establish contact with EMODnet from the start of the project to explore data flow and long-term uptake of data into EMODnet. This can be done via project partners involved in EMODnet and/or with Data Ingestion, to get advice on possible data flow and ways to ensure long-term storage and uptake of the project data into EMODnet as an EC marine data service.

Support by EMODnet Ingestion for EU projects:

The EU projects should initiate, formulate, and deploy DMPs themselves, taking into account their research and data collection plans, and considering the community standards and practices as promoted and used by EMODnet. However, EU projects can seek support from EMODnet Ingestion for reviewing their DMPs, before these are published and deployed, and for possible matchmaking with relevant data centres. For this purpose, EMODnet Ingestion manages a network of data management experts, consisting of coordinators of each EMODnet thematic group and representatives of the European marine data management infrastructures such as SeaDataNet, EurOBIS, EGD, and others, which have nodes in many European countries. Moreover, the data submission service of EMODnet Ingestion might be used for transfer, albeit for well documented and formatted metadata and data sets, while EMODnet Ingestion could also assist for sharing operational data streams with the EMODnet operational oceanography data exchange. However, it should be clear that EU projects themselves are and stay responsible for the quality and results of their data management activities, while EMODnet can give support, where possible. Those projects, that adopt the indicated common standards and concern original and new collected data sets, will qualify for uptake by EMODnet thematic groups.



Interreg



Co-funded by
the European Union



NEXT Black Sea Basin

<https://envrio.org/oceancast/>

🇬🇷 Είσοδος Πληροφορίες

CEANCAST
WEATHER & SEA DATA WHERE YOU FISH

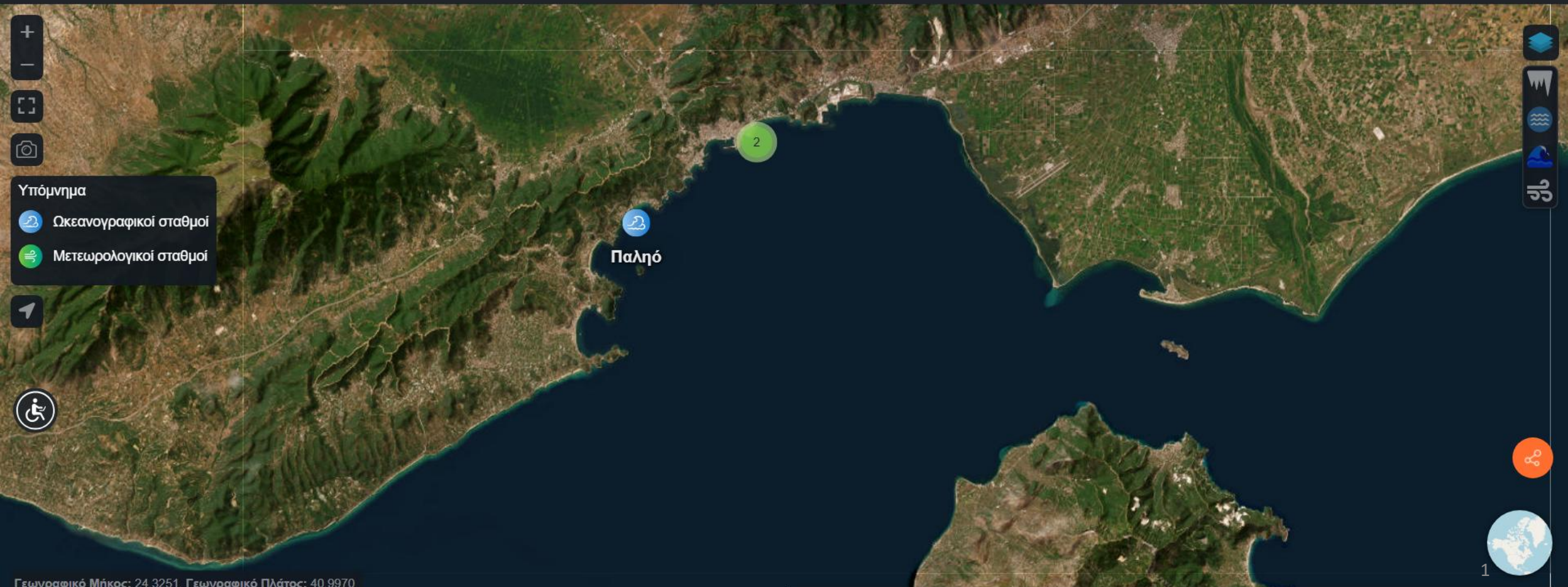

Interreg



Co-funded by
the European Union



NEXT Black Sea Basin

Guidelines for data sharing with EMODnet



ΔΗΜΟΚΡΙΤΕΙΟ
ΠΑΝΕΠΙΣΤΗΜΙΟ
ΘΡΑΚΗΣ

DEMOCRITUS
UNIVERSITY
OF THRACE

Georgios Sylaios, DUTH

03 July 2025, Kavala

The Challenge in marine data sharing and exchange

- **Reliable** and **accessible marine data** are key to supporting good research, and EU ocean policies, initiatives, and sustainable Blue Growth.
- The costs of marine data collection by European organizations is circa 1.4 billion Euro per year: ~ 1.0 billion for in-situ; ~ 0.4 billion for remote sensing.
- Existing marine data management infrastructures (SeaDataNet, EurOBIS, EGDI, ICES, CMEMS, and others) connected to EMODnet, already make a substantial amount of marine data **discoverable**, **accessible**, and **reusable**.
- However, still, a lot of valuable marine data **does not arrive in these infrastructures**, preventing its distribution through EMODnet and limiting its use.

Ocean Observation

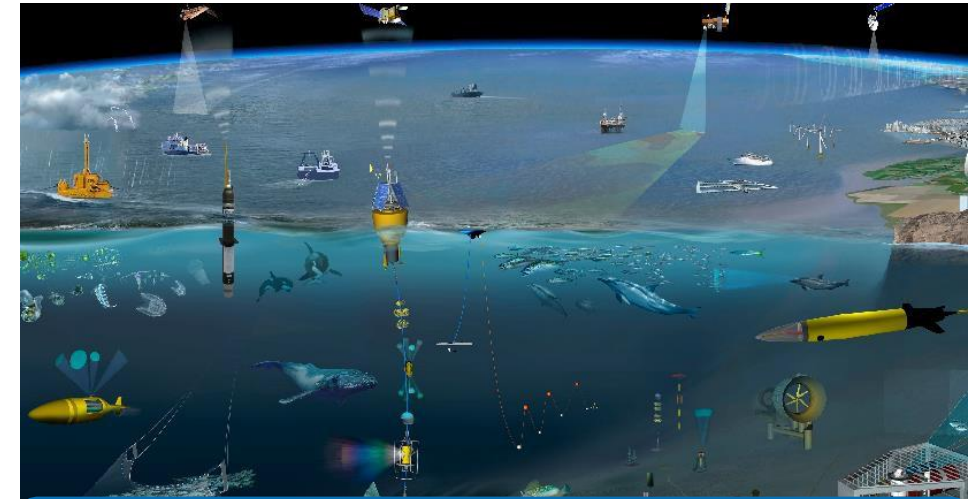

In Europe, we spent circa 1.4 Billion Euro a year in marine data acquisition (1.0 BE in-situ; 0.4 BE remote sensing)

Published in Frontiers in Marine Science 2020 (source: Glynn Gorick and the NeXOS project)
Future Vision for Autonomous Ocean Observations

What is EMODnet?



EMODnet



European Marine
Observation and
Data Network

- An **EC marine data service**, funded by the European Commission 16 years ago,
- Become **European authority and regional best practice** in the marine data domain,
- **Specializes in the insitu data**, all of the ocean observations that are collected in or around the water (it can involve the seabed and below or the air just above the water),
- **Delivered by a network of > 120 leading organisations**, working in collaboration with national, regional and EU marine data management initiatives and infrastructures;
- It is a **key marine knowledge initiative** working with Copernicus Marine Service **provides the back-bone for the European marine data space**, the European Digital Twin Ocean and a key contributor to the Global Ocean Data Ecosystem and digital commons.

EMODnet – Added Value

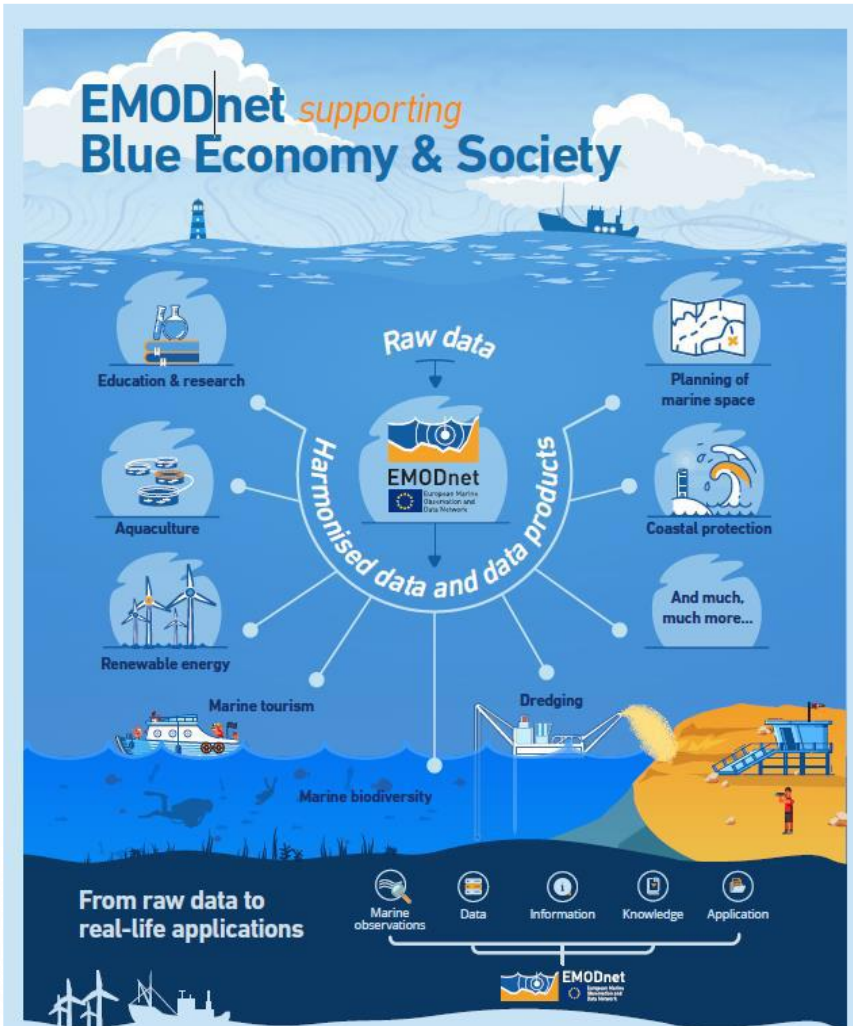

From raw data to real-life applications

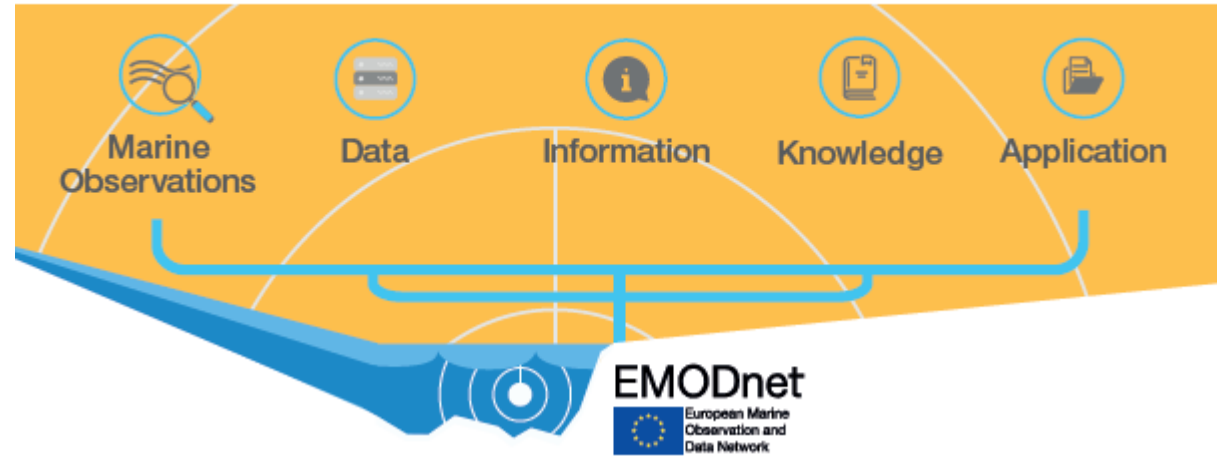

Offers:

- FAIR pan European data
- data products like maps, High Res. DTMs that can be used anywhere
- Collect data once, use many times.
- Assemble, standardise, harmonise, quality control, integrate.
- Visualize and make data come alive.
- reduce uncertainty;
- increase productivity and cost effectiveness;
- add value and impact to your data;
- stimulate innovation.

EMODnet themes-portals

Until recently EMODnet provided access to European marine data across **7 discipline-based themes-portals**:

	<p>BATHYMETRY Data on bathymetry (water depth), coastlines, and geographical location of underwater features: wrecks.</p> <p>USE CASES INFO ACCESS</p>		<p>GEOLOGY Data on seabed substrate, sea-floor geology, coastal behaviour, geological events, and minerals.</p> <p>USE CASES INFO ACCESS</p>	<p>SEABED HABITATS Data on modelled seabed habitats based on seabed substrate, energy, biological zone, and salinity.</p> <p>USE CASES INFO ACCESS</p>	
	<p>PHYSICS Data on salinity, temperature, waves, currents, sea-level, light attenuation, and FerryBoxes.</p> <p>USE CASES INFO ACCESS</p>		<p>BIOLOGY Data on temporal and spatial distribution of species abundance and biomass from several taxa.</p> <p>USE CASES INFO ACCESS</p>	<p>CHEMISTRY Data on marine litter and the concentration of nutrients, organic matter, pesticides, heavy metals, radionuclides and antifoulants in water, sediment and biota.</p> <p>USE CASES INFO ACCESS</p>	
	<p>COASTAL MAPPING Data on coastal areas across Europe, especially bathymetry and coastal mapping.</p> <p>USE CASES INFO</p>		<p>HUMAN ACTIVITIES Data on the intensity and spatial extent of human activities at sea.</p> <p>USE CASES INFO ACCESS</p>		

One single portal

<https://emodnet.ec.europa.eu/en>

One central map viewer

to visualise all EMODnet data

1 OCEAN 1 EMODnet

One single portal

One central metadata catalogue

to enhance data search and discovery

140 partners

+100 use cases

Discover, visualise and download marine data and products across 7 thematics and hundreds of parameters



BATHYMETRY



HUMAN ACTIVITIES



PHYSICS



GEOLOGY



SEABED HABITATS



CHEMISTRY



BIOLOGY

EMODNET.EC.EUROPA.EU

One central map viewer

EMODnet Map Viewer

EN English

Layers Catalogue

Search layer

- Administrative units >
- EMODnet Bathymetry >
- EMODnet Biology >
- EMODnet Chemistry >
- EMODnet Geology >
- EMODnet Human Activities >
- EMODnet Physics >
- EMODnet Seabed Habitats >
- EU-China EMOD-PACE project >

+ Add external layers

Marine regions: Search for a region ...

Change basemap: EMODNET World Base Layer

200 km

EMODnet European Marine Observation and Data Network



EMODnet Map Viewer

EN English

Legend

Wind Farms (polygons)

- Approved
- Dismantled
- Planned
- Production
- Under Construction
- Test site

Mean depth in multi colour (no land)

- 8000 m
- 3500 m
- 2000 m
- 1000 m
- 450 m
- 150 m
- 50 m
- 10 m

200 km

-4.90610, 58.76724

EMODnet European Marine Observation and Data Network

One central metadata catalogue

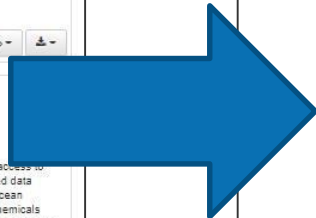

Integrated data services

Data Services directly accessible from EMODnet landing page

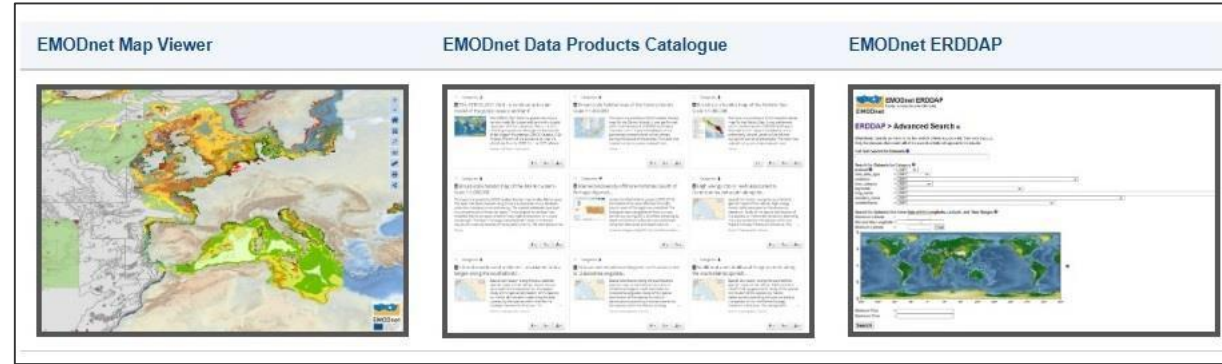

EMODnet Map Viewer interface showing layers like Administrative units, EMODnet Bathymetry, Coastlines, Data quality, and Depth. The map displays bathymetry data with a color scale from red (shallow) to blue (deep). A black box highlights a specific area on the map.



ERDDAP server @ EMODnet interface. The page is titled 'ERDDAP > griddap > Make A Graph'. It shows dataset information for 'EMODNET Bathymetry DTM 2020 full' and allows users to configure graph parameters such as X and Y axes (longitude and latitude), dimensions, and graph settings. A small map on the right shows the selected area.

Interreg



Co-funded by the European Union

NEXT Black Sea Basin



EMODnet

European Marine Observation and Data Network

GEOSS Portal

International portal, implemented by ESA



Ocean Data and Information System (ODIS)

Implemented by IODE of IOC/UNESCO



EMODnet's FAIR common metadata catalogue is the backbone for EMODnet's contribution to the the **global ocean data digital ecosystem**, the UN Decade of Ocean Science for Sustainable Development, Sustainable Development Goals (SDG) agenda and **machine-machine data harvesting**.

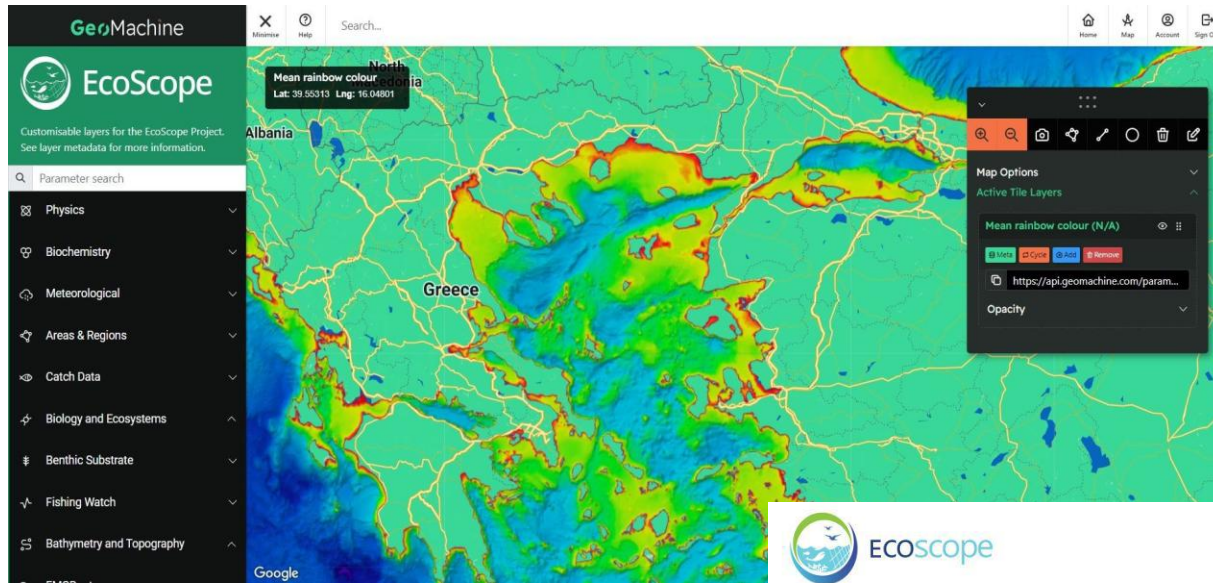

Ecoscope platform integrates meteorologic, climate, oceanographic, biogeochemical, socio-economic, biological and fishery data for all EU Seas from various repositories. The platform prepares the data in the appropriate format to be imported in ecosystemic and fishery models, like the Ecopath with Ecosim model.



Seabed Habitats

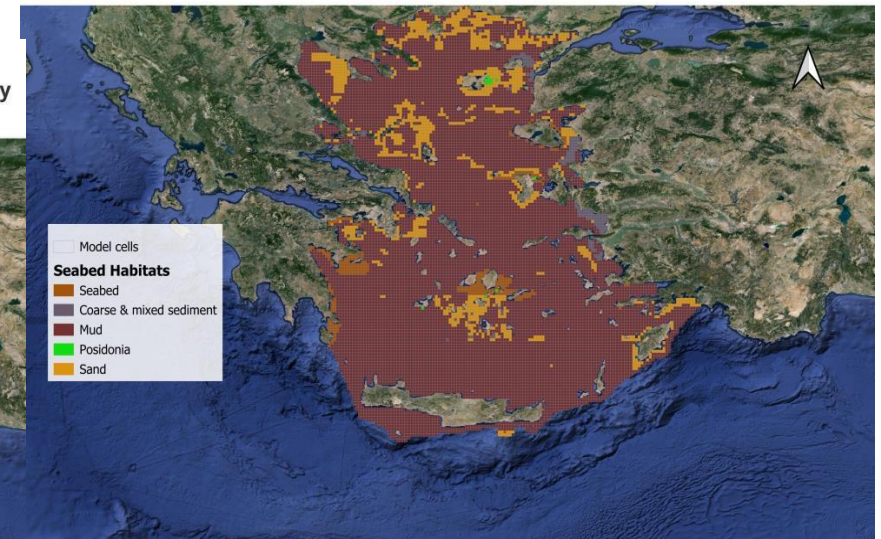

Bathymetry



EMODnet Bathymetry and Seabed Habitat data are important for modeling the spatial variability of fishing impacts and running scenarios for the designation of Marine Protected Areas using the Ecospace component of the EwE model.

Collaborating with Europe's Marine Data Backbone

- The EMODnet Thematic groups rely and interact with European marine data infrastructures such as **SeaDataNet**, **EurOBIS**, **EGDI**, **ICES**, and others.
- These infrastructures have established nodes in many European countries.
- Their data centres offer validation, long term stewardship, and FAIR documentation, following agreed community standards.
- Currently, data from more than a thousand data originators from public, research and private sector in the European marine data landscape are managed.

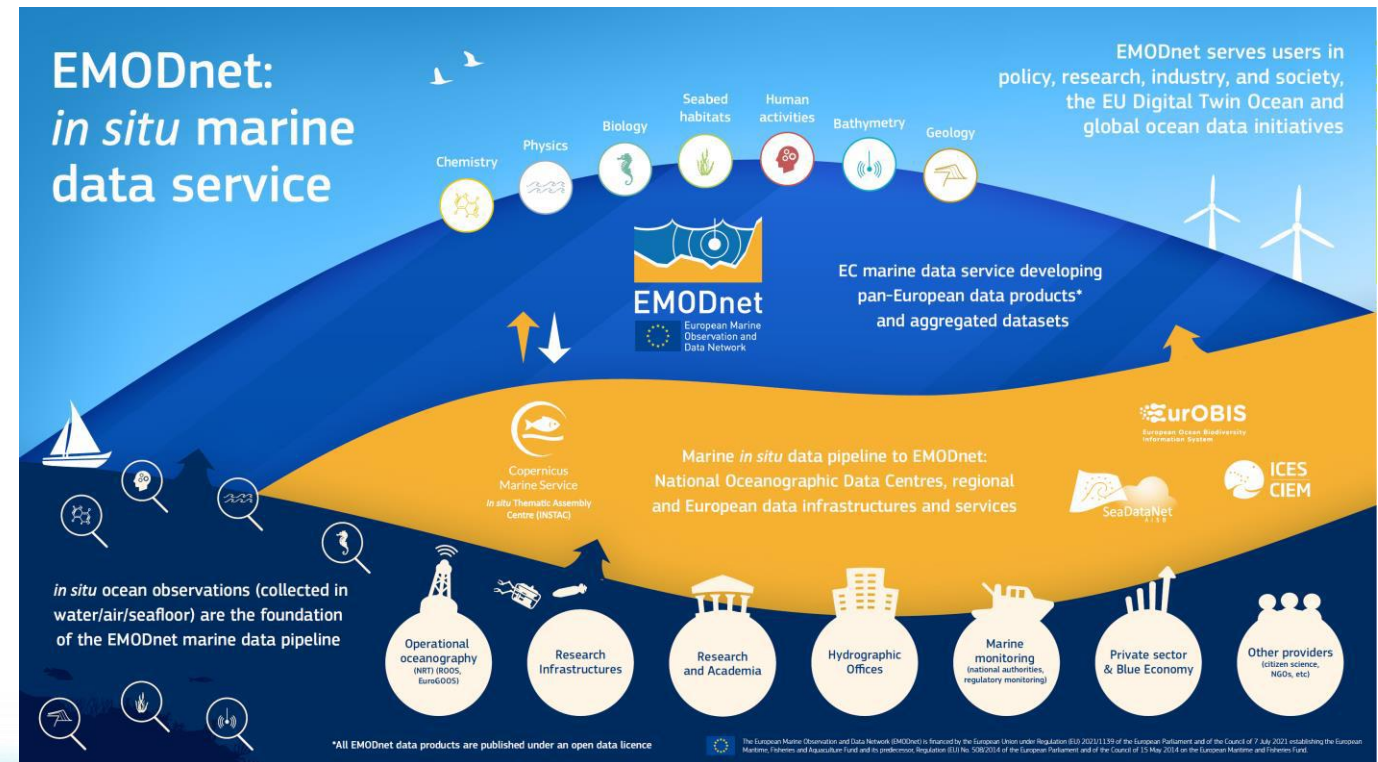

FAIR principles

To enable and enhance the reuse of data by both humans and machines

F – “Your data can be discovered by others”

- Assigned **persistent identifier** for unique identification and versions management
- Rich descriptive **metadata** for searching and finding



F indable

A – “Your data can be made available to others”

- Accessible on the **internet** or by other applications
- **Access restrictions and conditions** should be clearly specified



A ccessible

I – “Your data can be integrated with other data”

- Open **standards (formats, vocabularies)** should be applied to (meta)data
- **Identifiers** for linking with other data, metadata, information



I nteroperable

R – “Your data can be reused by others”

- Clear **license** to specify the reuse conditions and permissions (CC-read, understood by machines)
- **Provenance** information on how the data was created



R eusable

Marine Data Management guidelines - General principles for metadata

Marine and ocean data include a very wide range of measurements and variables derived from a broad spectrum of multidisciplinary research projects and monitoring programmes.

General principles for metadata:

- data should **include enough meta-data** to be processed, and include additional textual or standardized “history” or “comment” fields to prevent any loss of information,
- provide similar structure and meta-data for different data type such as vertical profiles and time series.
- For all types of data, information is required about:
 - **Where** the data were collected: location (preferably as latitude and longitude) and depth/height
 - **When** the data were collected (date and time in UTC or clearly specified local time zone)
 - **How** the data were collected (e.g. sampling methods, instrument types, analytical techniques)
 - **How you refer** to the data (e.g. station numbers, cast numbers)
 - **Who** collected the data, including name and institution of the data originator(s) and the principal investigator
 - **What has been done** to the data (e.g. details of processing and calibrations applied, algorithms used to compute derived parameters)

General principles for data

- Depending on the data type, the acquisition systems, the delivery time frame or operations of the archiving centre, **there is not a unique used data model and structure** and the original measurement format may not be the same as the format that the archiving centre can accept.
- Projects are encouraged to **adopt the common formats for metadata and data** with the existing marine community practices and make use of these common standards for their data packages submissions.
- This will enable the **easiest integration** of their data sets into the current data systems and make them re-usable.
- A summary of these basic data management guidelines used by the marine community can be at:

<https://www.emodnet-ingestion.eu/guidelines/how-to-handle-different-marine-data-types>

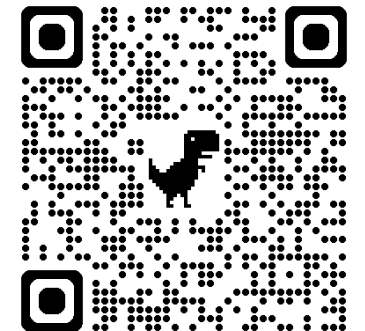
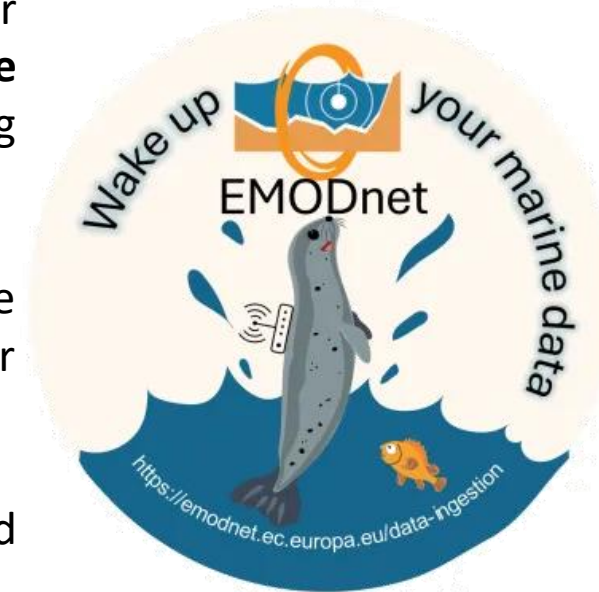

Seagrass Example - Workflow

In order to publish Seagrass data to EMODnet you need access to



GBIF

Integrated Publishing Toolkit.

<https://www.gbif.org/ipt>

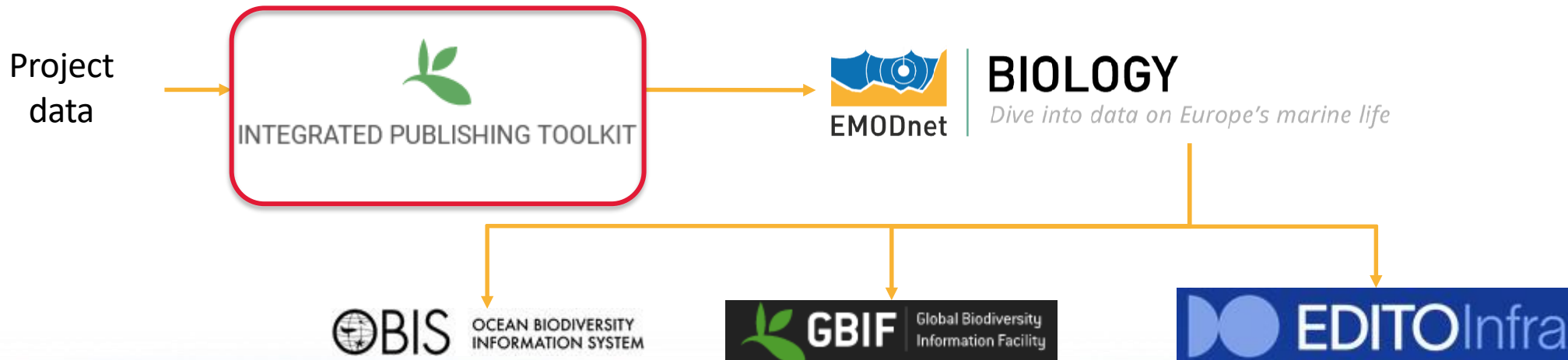



Seagrass Example – Data format template

- Self-paced training course ‘Contributing datasets to EMODnet Biology’

<https://classroom.oceanteacher.org/enrol/index.php?id=958>

- Data file template

https://emodnet.ec.europa.eu/sites/emodnet.ec.europa.eu/files/public/EMODnetBiology_DwC_2020-template.xlsx



- Quality check tool as [R](#) package or [Rshiny](#) application

<https://github.com/EMODnet/EMODnetBiocheck>

<https://rshiny.lifewatch.be/BioCheck/>

European Ocean Biogeographic Information System

BIOLOGY
Dive into data on Europe's marine life

OBIS-ENV schema

Event table
eventID

Sample or Observation
(time, location, depth, event hierarchy...)

Occurrence table
eventID
occurrenceID

Occurrence details
(taxonomy, identification)

Extended Measurement or Facts
eventID
occurrenceID

Sampling protocol
Sampling effort
Environment/habitat variables
Biological variables

Excel file

OBIS manual: <https://www.obis.org/manual/>

DwC terms: <https://dwc.tdwq.org/terms/>

eventID	eventDate	decimalLatitude	decimalLongitude	institutionCode	datasetName	maximumDepthInMeters	minimumDepthInMeters
	ISO 8601:2004(E) format	In WGS84	In WGS84	that identifies the institution to which the collection belongs, if exist. If not, use a short version or acronym of the name of the institution.	title of the dataset		

eventID	occurrenceID	basisOfRecord	occurrenceStatus	scientificName	scientificNameID	identificationQualifier
		FossilSpecimen, LivingSpecimen,	Present or Absent		http://www.marinespecies.org	

Marine Litter Example – Data format template

Litter Categories



Established Protocols and Sources for Marine Litter Assessment

- For **beach litter**: UNEP, OSPAR, MCS, Slovenia, ICC.
- For **floating litter**: HELMEPA, NOAA, ECOOCEAN and Hinojosa/Thiel (2009).
- For **seabed litter**: OSPAR/ICES list (IBTS) and HELMEPA.
- For **micro-litter**: CEFAS.

Marine Litter Example – EMODnet tools



- **Marine Litter Manager Tool** : helps users to generate EMODnet beach and seafloor litter data formats by means of a Python tool.
- **EMODnet Beach Litter Format Validator** : online tools to check that the file format is correct and ready for data transfer.
- **Beach litter vocabularies** : provides the official and updated lists of terms used to describe beach litter data in the EMODnet Chemistry format
- **EMODnet Seafloor Litter Format Validator** : online tools to check that the file format is correct and ready for data transfer.

Marine Litter Example – Marine Litter Manager

Marine Litter Manager

Beach Litter Files Beach Litter Models

FORMATS BEACH LITTER BEACHES SURVEYS ANIMALS & LITTER SURVEYS PLOT PARAMS PLOT

The sheet for BEACHES: 1 The sheet for SURVEYS: 2
The sheet for ANIMALS: 2 The sheet for LITTER: 3

Load Litter Input File C:/Users/Alex/Document
Output file name (.xls):
Load Model C:/Users/Alex/Document
Model file name (.csv):

Marine Litter Manager Infobox:
Beach Litter Input File: C:/Users/Alex/Documents/PYTHON-OGS/litter/BeachLitter-Files/BeachLitter-Files/BeachLitter_InputExamples/Input_Params_in_another_sheet.xls
The model C:/Users/Alex/Documents/PYTHON-OGS/litter/BeachLitter-Files/BeachLitter-Files/BeachLitter_ModelsExamples/Model_params_another_sheet.csv has been imported!

Marine Litter Manager

Beach Litter Files Beach Litter Models

FORMATS BEACH LITTER BEACHES SURVEYS ANIMALS & LITTER SURVEYS PLOT PARAMS PLOT

BeachCode(0): A	Check	BeachName(1): D	Check
Country(2): B	Check	BeachInfoAmmendment(3):	Check
FillingDate(4): Q	Check	FillingName(5):	Check
FillingPhone(6):	Check	FillingMail(7):	Check
FillingInstitute(8):	Check	UrbanizationDegree(9):	Check
Reference beach(10):	Check	BeachWidthLow(11): G	Check
BeachWidthHigh(12): H	Check	BeachLength(13): I	Check
BeachLatitude(14): L	Check	BeachLongitude(15): M	Check
CoordinateSystem(16): P	Check	BeachBack(17): J	Check
BeachBackOther(18):	Check	BeachBackDevelopment(19):	Check



EMODnet Ingestion Ambassadors

Network of 50 National Data Centres, specialized marine centres, and all EMODnet thematic coordinators ensuring provision of trustable data and products.

BATHYMETRY



BIOLOGY



CHEMISTRY



GEOLOGY



HUMAN ACTIVITIES



PHYSICS



SEABED HABITATS



Data Ingestion process

Use is made of standards, best practices, and existing marine data management infrastructures, data centres and pathways towards the EMODnet

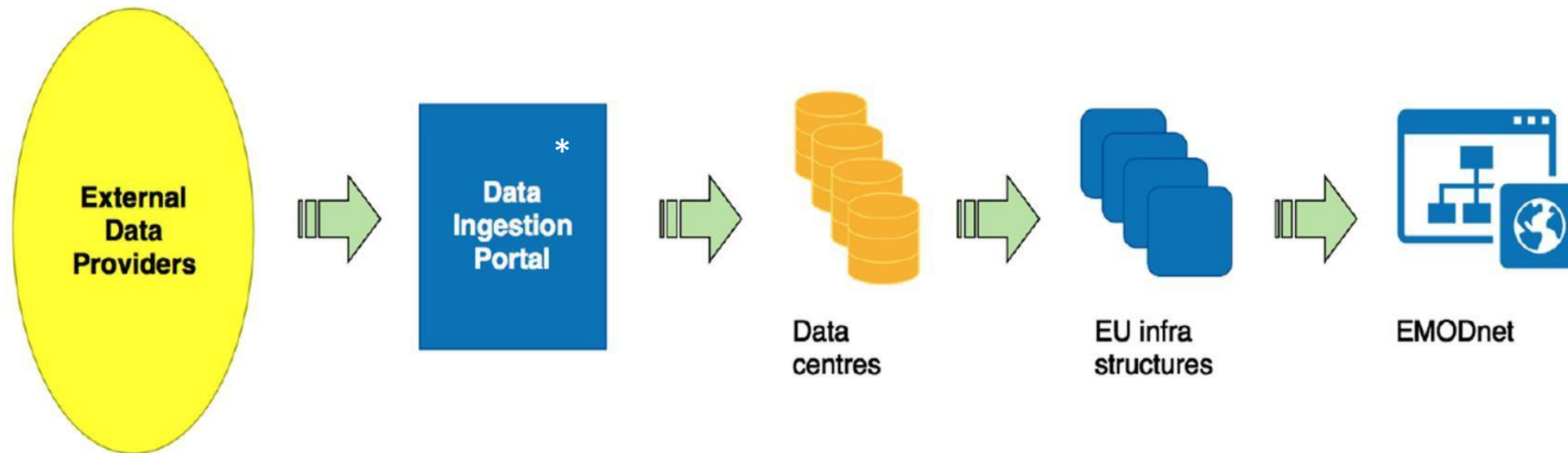

Workflow from submission to elaborating and processing for publishing in EMODnet

* Migration to Central Portal, 2024

A step-by-step approach

Distinction between 2 phases in the life cycle of a data submission:

- **Phase I:** from data submission to publishing *'as is'*
- **Phase II:** appropriated expert data centers took over the submitted data, elaborate and integrate them in national, European infrastructures and EMODnet for publishing and sharing with the wider community

WELCOME NIKOLAOS KOKKOS | VIEWING AS DATA SUBMITTER | ? | LOGOUT

Process Info Organizations Dataset Identification Data Types Locations & Dates Data Links & Finish

Process Info ⓘ

* = Required

FORM INFORMATION	
Submission identifier (UUID)	1dd3a10a-695e-40fc-9e20-89dd9864d23b
Status	Drafting form part 1 by Data Submitter Rejected by DC Contact: NO
Assigned Data Centre	
Contact Data Centre	
Last Update	2025-06-20 19:12:31.412354
Dataset URL	

- 5 conceptually similar groups of **ISO/INSPIRE** compliant **metadata elements**, extended use of **vocabularies**
- The **ownership** of the data is **transparent and clear** throughout the process, giving **proper acknowledgments** and **credits** to the originating **Organizations and scientists**



Submission Service



Energy, Climate change, Environment

European Marine Observation and Data Network

About | Data Services

Welcome to the **Submission Service** of the

This service facilitates you to submit marine

Press "**Continue**" to start.

Continue

emodnet requires you to authenticate

Sign in to continue

I am not nikolaoskokkos@gmail.com
(External)

[Logout](#)

**EU Login Account
Is needed**

Or

Choose your verification method



**Trusted Platform or Security
Key**

Use a Trusted Platform or Security
Key to authenticate with EU Login.



Sign in

Search

Help | FAQ Downloads

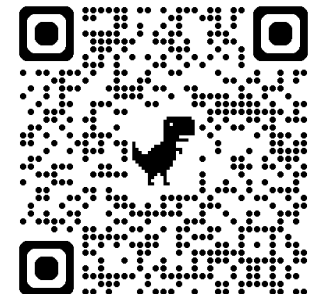

Submitter's Dashboard

Submitter's Data Submission List

Add

Show entries

Submission identifier (UUID) ▾	Title of dataset ▾	Status ▾	Last Update ▾	Controls
<input type="text" value="Enter Submission identifie"/>	<input type="text" value="Enter Title of dataset..."/>	<input type="text" value="Select..."/>		
1dd3a10a-695e-40fc-9e20-89dd9864d23b	Efxinnos - Seagrass - North Aegean	Drafting form part 1 by Data Submitter	2025-06-20 19:23:57.522252	View Edit
37c2a56b-9f34-403a-baa7-f6da8a4500db	Fishing weir areas on the territory of the Black Sea basin management region	Drafting form part 1 by Data Submitter	2025-05-22 13:54:12.431628	View Edit

Showing 2 entries of 2

Organizations Information



1st step:

1. Fill in the contact person's details:
2. Fill in the organizations responsible for the dataset
3. Select the language used for completing the form

Organizations

* = Required

CONTACT PERSON FOR THIS DATASET SUBMISSION FORM ⓘ

Name	Nikolaos
Surname	Kokkos
Email	nikolaoskokkos@gmail.com <small>Email is taken from your profile</small>
Country	Greece <small>Country is taken from your profile</small>
Organization	Democritus University Of Thrace, Department of Environmental Engineering, Special Account for Research Funds

ORGANIZATIONS RESPONSIBLE FOR THE DATASET ⓘ

Country *	Greece	
Organization *	Democritus University Of Thrace, Department of Environmental Engineering, Special Account for Research Funds	
Email of organization	ecolabduth@gmail.com	
Role of organization *	Originator of Dataset	

ADD

LANGUAGE USED FOR COMPLETING FORM

Language	English
-----------------	---------

Data Identification

2nd step:

1. Fill in the **dataset general information**
2. Fill in the **dataset formats**
3. Fill in the **data quality processing information**
4. Fill in the **documentation**
5. Fill in the **dataset availability** (license type)
6. Fill in the **dates of creation**

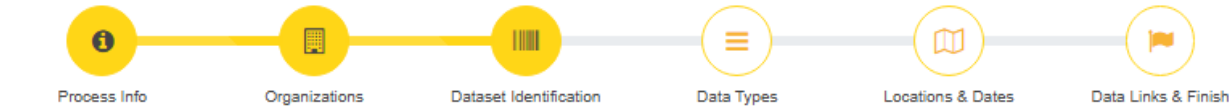

Dataset Identification



* = Required

DATASET GENERAL INFORMATION

Title of dataset * ⓘ

Narrative summary of dataset * ⓘ

DATASET FORMATS

Dataset format * ⓘ  

DATA QUALITY PROCESSING INFORMATION

Summary of data quality processing ⓘ

DOCUMENTATION

Documentation ⓘ

DATASET AVAILABILITY

Public access ⓘ

License for use * ⓘ

Type ⓘ

DATES

Date of metadata creation ⓘ

Date of dataset creation * ⓘ

Data Types

3rd step:

1. Fill in the dataset collection and processing information

- Project/Programme Name
- Summary of processing methodology

2. Fill in the observations type



Data Types

* = Required

DATASET COLLECTION AND PROCESSING INFORMATION

Project / Programme ⓘ

Summary of processing methodology ⓘ

OBSERVATIONS

Observation Type * ⓘ ✎ 🗑

NEXT Black Sea Basin

Locations & Dates

4th step:

1. Fill in the **geographic bounding box** (it's possible to select area with mouse)
2. Fill in the **sea areas** (standard common names)
3. Fill in the **period covered** by the dataset

Locations & Dates

* = Required

GEOGRAPHIC BOUNDING BOX

Geographic Bounding Box *

West Bound Longitude:

South Bound Latitude:

East Bound Longitude:

North Bound Latitude:

Coordinate reference system EPSG:4326 (WGS84)

SEA AREAS

SEA AREA Aegean Sea

ADD

PERIOD COVERED BY THE DATASET

Start Date *
Provide a date in 'yyyy-mm-dd' format.

End Date *
Provide a date in 'yyyy-mm-dd' format.

Data Links & Finish

Final step:

- **Validate** the submission (not the files)
- **Save draft** (draft will be saved temporarily)
- **Choose file** (after the final save)

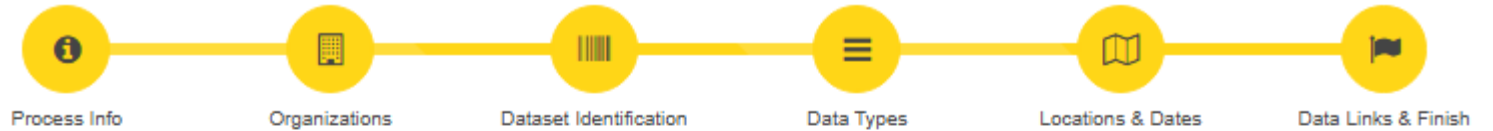

Data Links & Finish

* = Required

DATA LINKS & FINISH

Choose File Please perform "Final Save" of the form before uploading the data package

Validate
Save draft
Final save
Cancel

Previous

Interreg



Co-funded by
the European Union



NEXT Black Sea Basin
NEXT Black Sea Basin

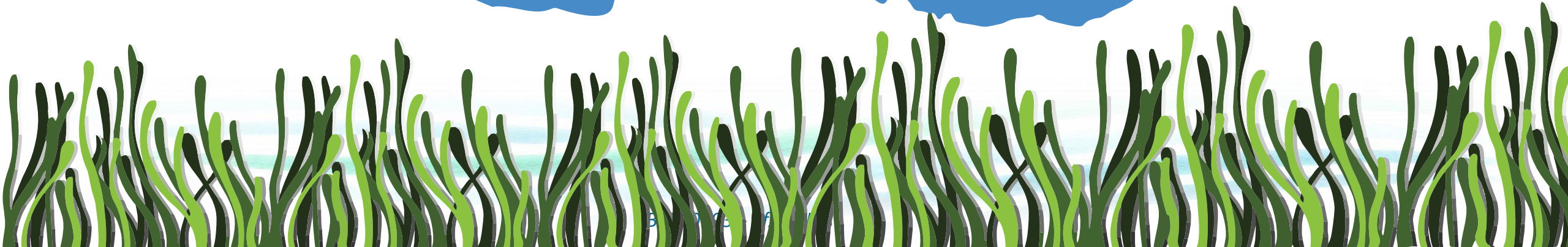

HUESKER Geosynthetics for Hydraulics



- # Introduction of HUESKER Synthetic GmbH
- # Hydraulics with Geobags and Soiltain Tubes
- # Practical Installation & Projects
- # Conclusions of Geobags and Soiltain Tubes
- # Dewatering with Soiltain Tubes
- # Incomat Concrete Mattrass
- # Sustainability and HUESKER Eco and Bio Line

Where tradition...



1861
Founded as H.&J. Huesker & Co.



... meets progress!



2016
New production hall
in Gescher



2016
New office and production
in São José dos Campos (Brasil)



2016
Takeover of „NBW Mining“ Australia
(Maitland, Australia)

2016
Launch Active Geo-Composites
Tektoseal® Active

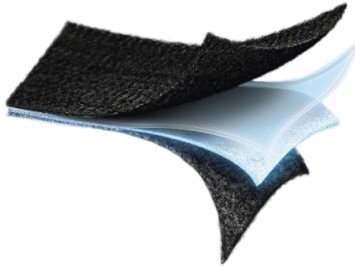

2016
New office and production
in Shelby (USA)



2017
New production
in Klin (Russia)



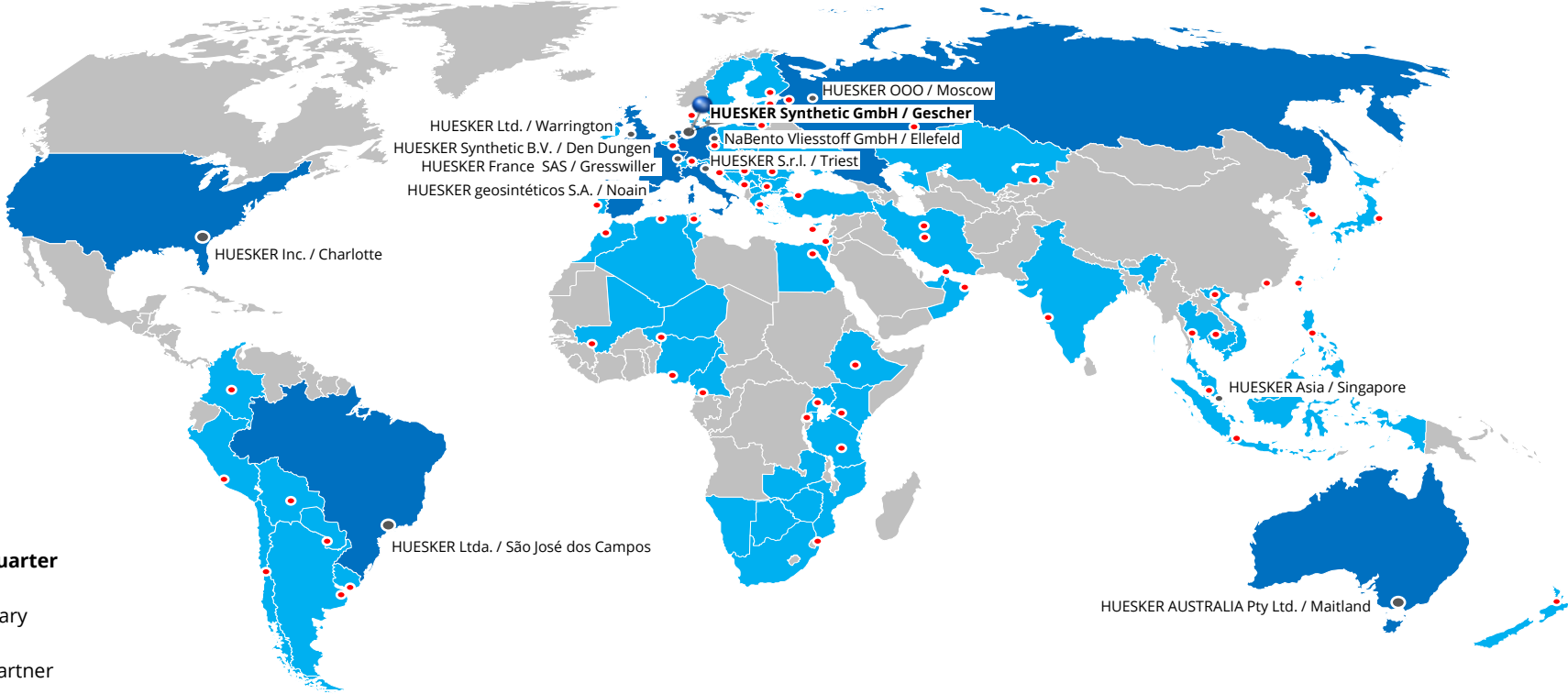

 **Headquarter**

 Subsidiary

 Sales partner

State-of-the-art Production



- # Our engineers continuously develop creative, new and market-driven answers for technically high demanding challenges
- # Our highly competent Engineering Department is a basis for our economical success
- # Every seventh employee at HUESKER is an engineer



Product Groups (Geo)

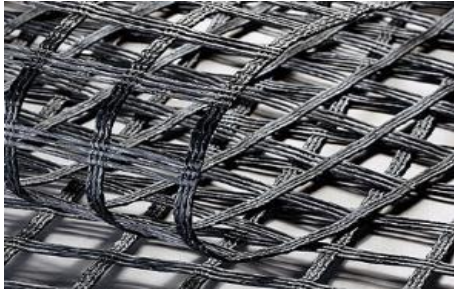

Geogrids



Container and Tubes



Wovens



Non-Wovens



GCL

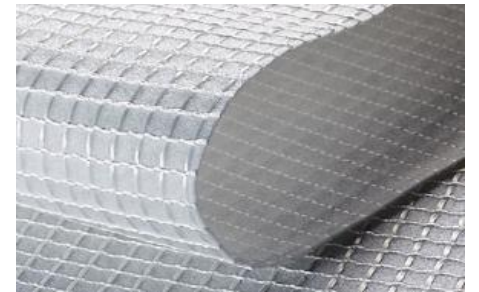

Composites

Tube Applications



Bag Applications

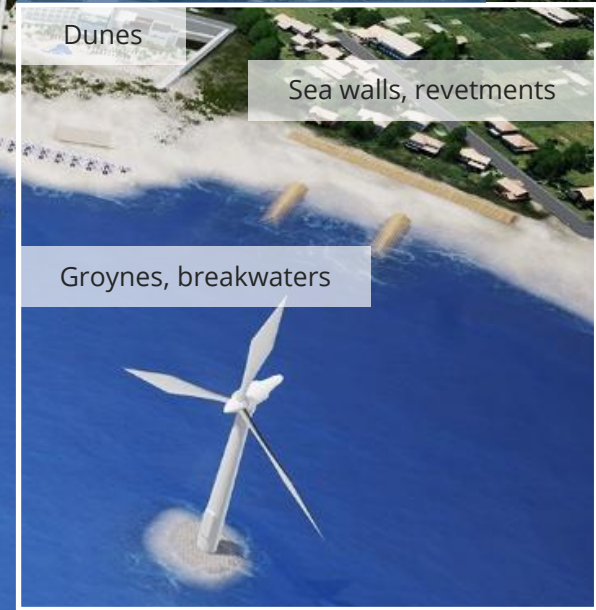

Today almost every building material is used in hydraulic engineering!



Only the use of geotextile elements allows the use of the naturally occurring sand on-site as filling/construction material.

Economically and ecologically

Integration into the environment

- Sand colored material fits well into the environment
- Fast colonization by the maritime flora & fauna
- High robustness and long-term abrasion resistance
- Smooth installation procedure
- Proven ecological compatibility



Application overview Bags

The application possibilities are versatile:
Dune reinforcement, revetment construction,
scour protection, breakwaters and groynes.



Safe building structures thanks to high adaptability
Structural deformations are compensated for by the
small-format and flexible elements.

Products and configuration options:



SoilTain Bags Xtreme

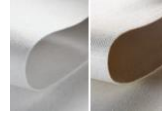

SoilTain Bags



Transport/filling loops



Different closures



Filter stable scour protection

The flexible, quick solution for scour filling or for
preventing scour formation. Quick installation
directly on the existing subsoil.



Material savings due to filter stability

Saving of filter layers, armourstone,
transport and CO₂.



Robust, permanently exposed structures

Abrasion and UV-resistant, vandalism proof with
SoilTain Bags Xtreme.



Ecologically compatible

Provides habitat for marine flora and fauna
and is characterized by the sustainable and
gentle installation method.

SoilTain Sand Bags - the alternative to stone revetments



- # Small-format, flexible container elements
- # Safe building structures thanks to high adaptability
- # Uncomplicated scour prevention and subsequent scour protection
- # Filter stable design enables material savings
- # Good integration into the natural environment
- # Vandal resistant solutions



SoilTain Sand Bags - the alternative to stone revetments

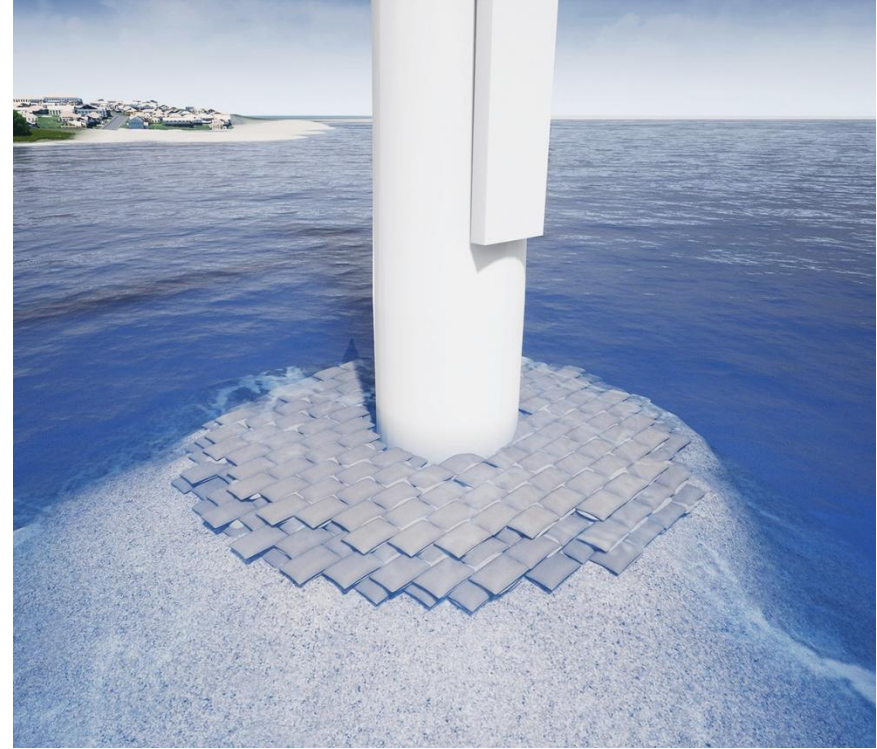

Application of BAW certified materials

Filling by use of a funnel and a backhoe



Closing with a handheld sewing machine



Installation by a backhoe with a modified grab



Revetments/Seawalls



Toe protection



Scour Protection



Structure Core/Filter Layer



Breakwaters/Groynes



Dune reinforcement



Overview of a typical bag construction site



Cement/sugar bags are not geosynthetic elements for hydraulics!



No design and no concept meet...



...wrong materials!

Application overview Tubes

The application possibilities are versatile: breakwaters, groynes, dams, dykes, dunes, land reclamation, and bank protection.

System component kit:

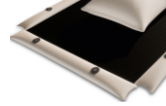

Scour apron



SoilTain Tubes

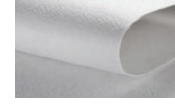

Protective non-wovens



Cover layer



Tube assembly for every project

Material adaptation, different filler necks and tube heads possible.



Safe use even with erosive subsoil

In the system with a scour apron, undermining of the hose is prevented.



Simple and fast in-situ filling

Filling of a 450 m³ tube possible in approx. 8 hours.



Ability to stack enables greater construction heights

Structures, several meters high for maximum protection, achievable.



Ecologically compatible

Provides habitat for marine flora and fauna and is characterized by the sustainable and gentle installation method.

Sustainable erosion control system

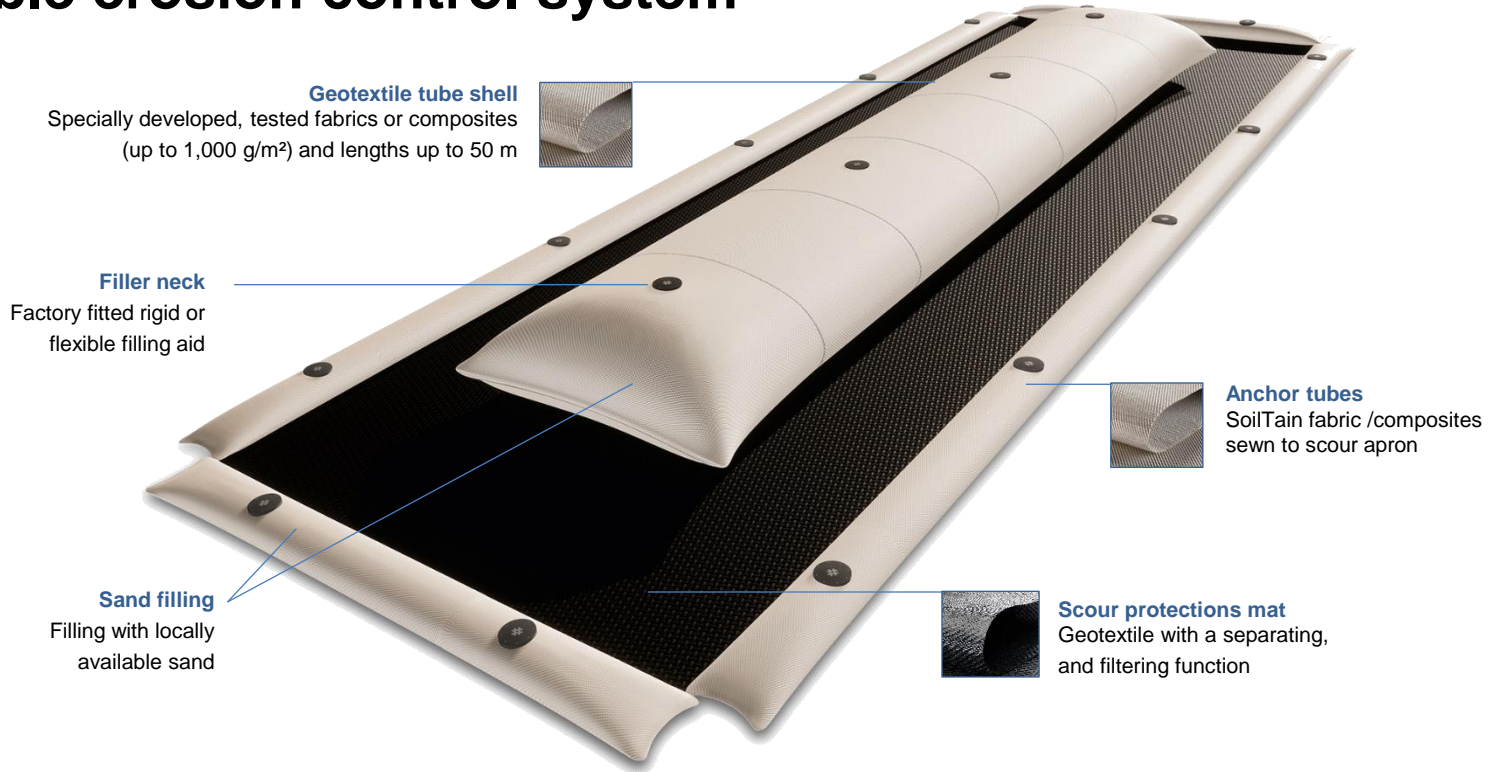

(Standard) Product Sizes

Diameter → from 1.0 m
up to 5.0 m



Length → from 10 m up
to 50 m



Tube Definition

- Long, approximately elliptic element after in-situ hydraulic filling with a sand/water slurry
- Tube containment shell for the sand consists of a permeable geotextile absorbing the occurring hoop stress

Customized Fabrication

Tube-diameter



Tube-lengths



Tube-material



Filler neck



- # **STANDARD material:** SoilTain PP 200/200 CP (only material for large diameter tubes)
- # Alternatives for special cases:
 - # SoilTain PP 105/105 DW, SoilTain PET 175/175 DWA30
 - # Limited to a circumference of 9,40m (Filling height of 1.60m)



Geosynthetic Tubes Installation

Extraction

Hydraulic extraction of filling sand by means of suction dredger or dredge pump.
Alternatively: Liquefaction of sand through addition of water in mixing tank and filling by means of slurry pump.

Delivery

Hydraulic delivery of sand/water mix to place of installation.

Filling

In-situ filling of SoilTain tube: water drains out while sand is retained in tube.

Integration

Possibilities for integration in landscape setting by covering with sand or overlaying with revetment system; optional stacking of tubes.

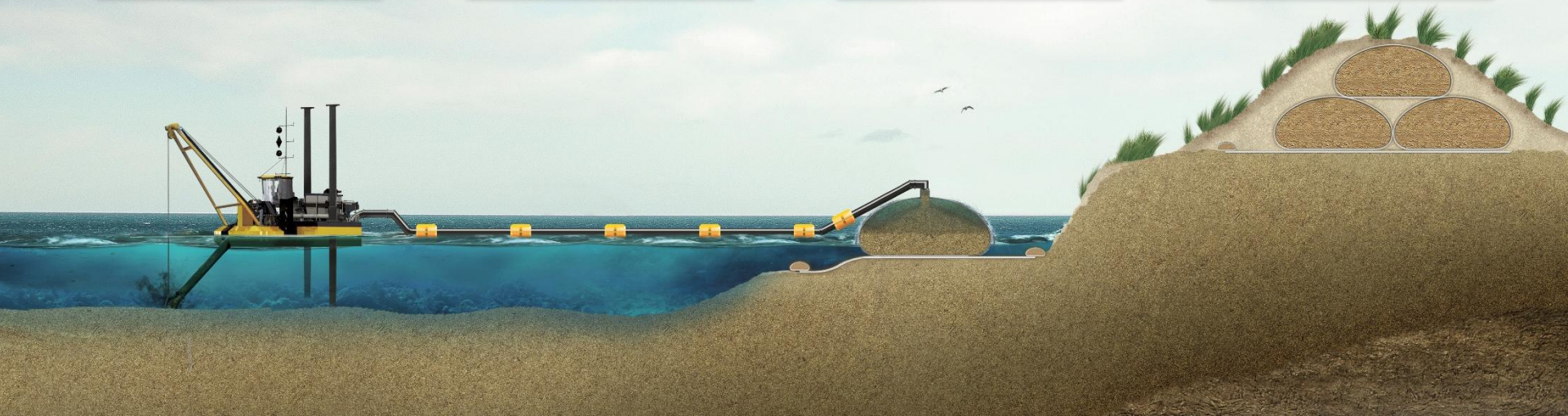

What is a Geotextile Tube?

Ring tensile element

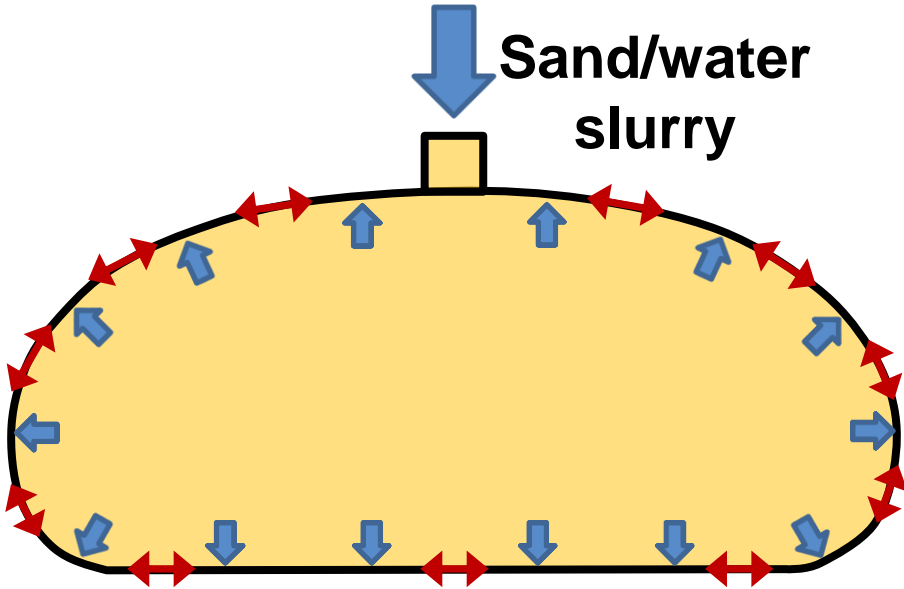

During filling: Pumping pressure

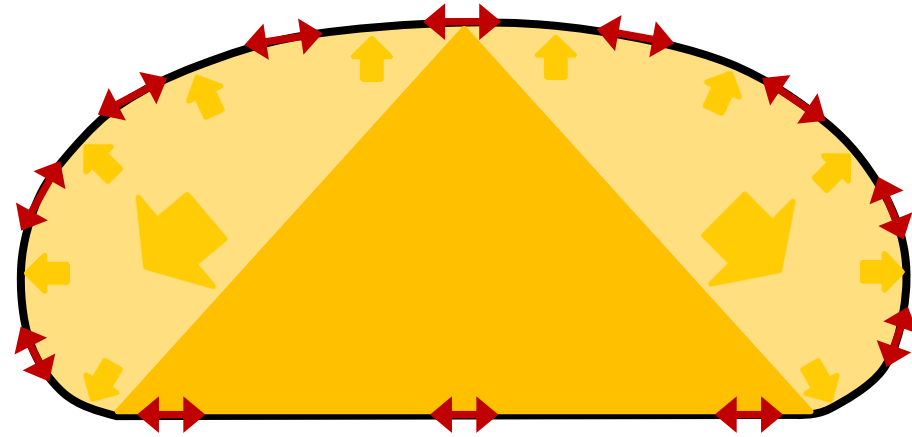

After filling: "internal sand pressure"/"confinement stress"

The beach immediately starts reacting



Kos Island, Neptune Beach Resort, 2015 (during installation)



Kos Island, Neptune Beach Resort, 2015 after installation

Before and After: Substantial Beach Widening



Kos Island, Neptune Beach Resort, before tube installation



Kos Island, Neptune Beach Resort, 2017

Source: Google Earth



Dune reinforcement



Camping Village Oasis, Italy

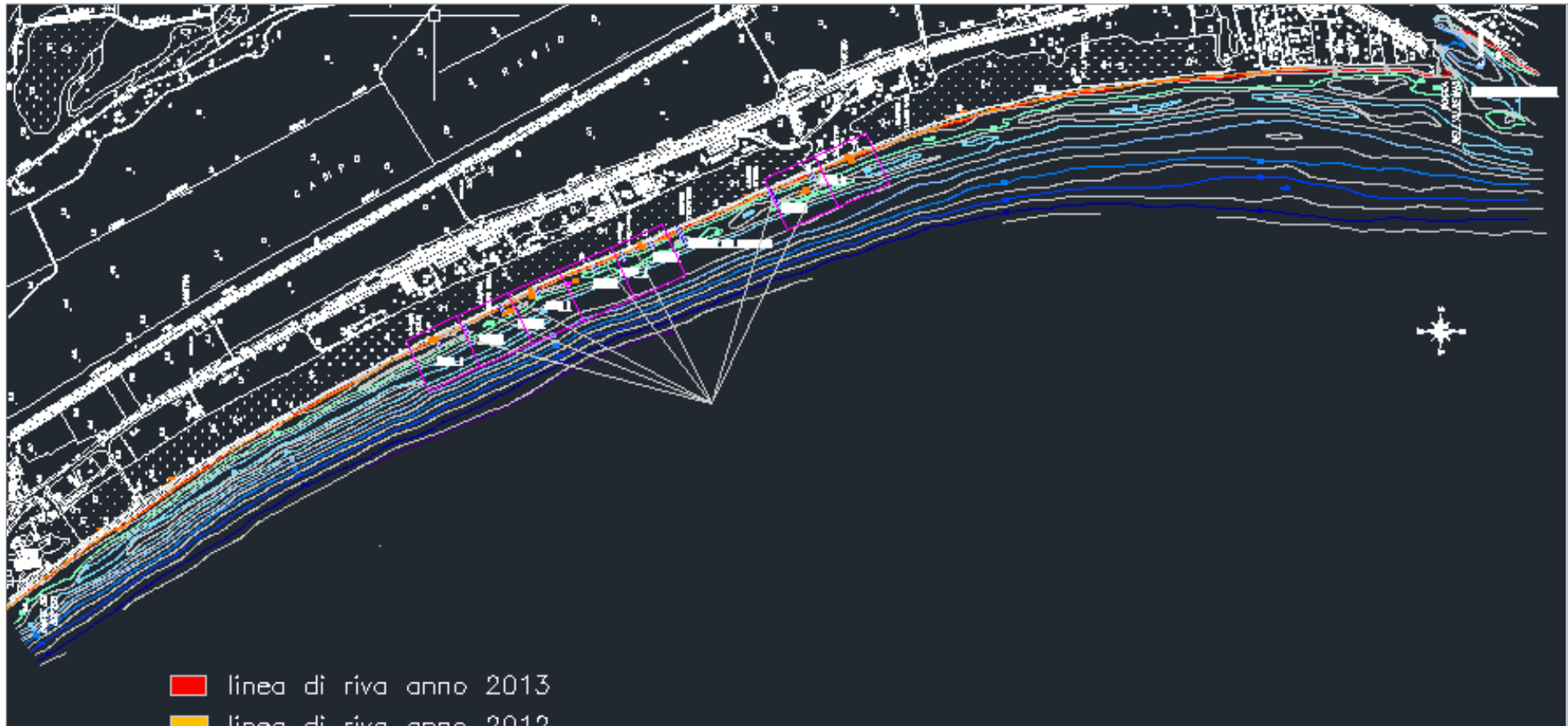

■ linea di riva anno 2013

■ linea di riva anno 2012

Groyne



SoilTain CP tube
Diameter=1.5m



Closed with Rigid Inlet



Pit Lake Lieske, GER



Lake Sedlitz (East Germany), former open pit: Lake area of 1,330 hectares; Max. water depth of 27 m



Source: google earth



Location of the cliff in front of the village of Lieske; Source: google earth

Cliff formation by wind induced waves (~ 0,7 m)



Cliffs up to a height of 5 m



Length of the affected area ~ 1.500 m

Eroded bank by wind induced waves (~ 0.7m)

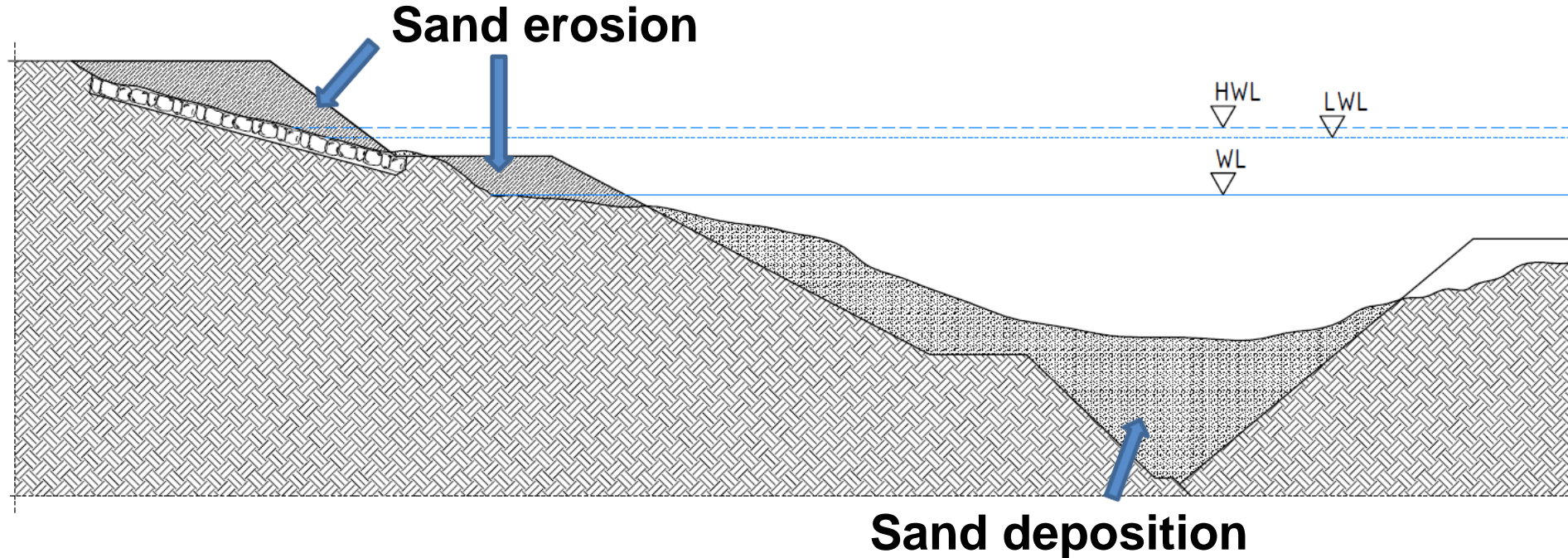

Bank protection by a stacked tube installation

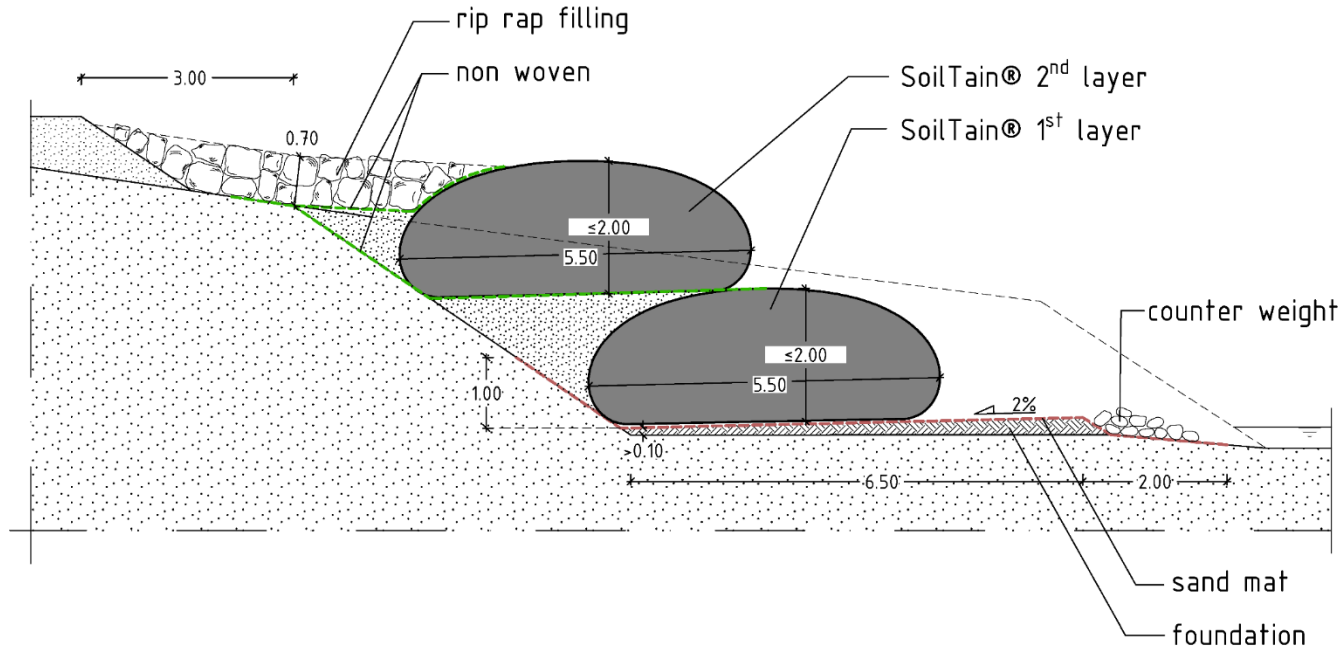

Installation process



Lay out of the empty tube on the prepared platform



Backfilling of the area after successful first layer installation





Artificial beach construction with breakwaters



Working scheme

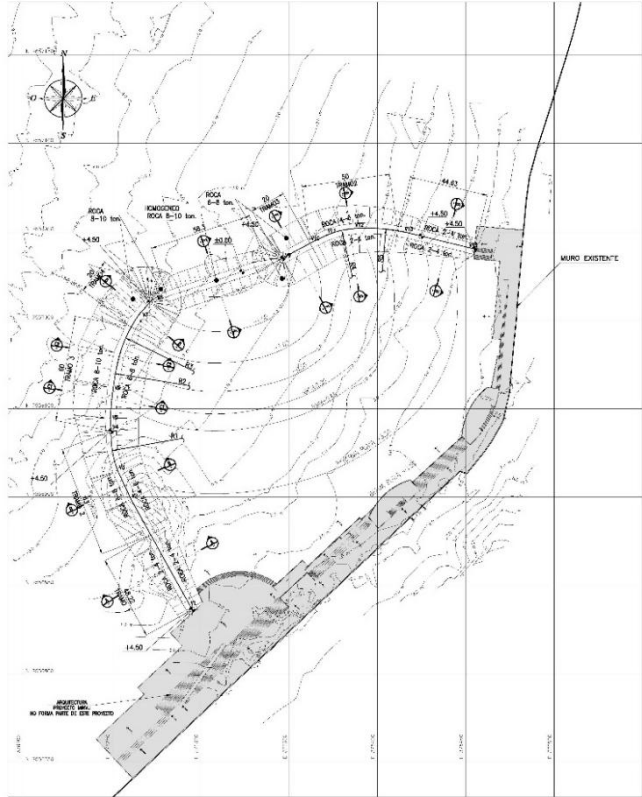

PLANTA OBRAS MARITIMAS
PLAYA EL SALTIRE, TOCOPILLA

Esc. 1:1000
(Medida en m)

Top view



Visualization of the completed work

Installation process



Installation frame to keep the unfilled tube in place



Tube filling by the aid of divers

Installation process



Use of a backhoe mounted slurry pump (type Dragflow, 140 m³/h) for tube filling



Installation of the rock cover (cushion layer of 0,3 to 0,5 tons; armour layer of 2 to 4, 4 to 6 and 6 to 8 tons rock)

Completed work



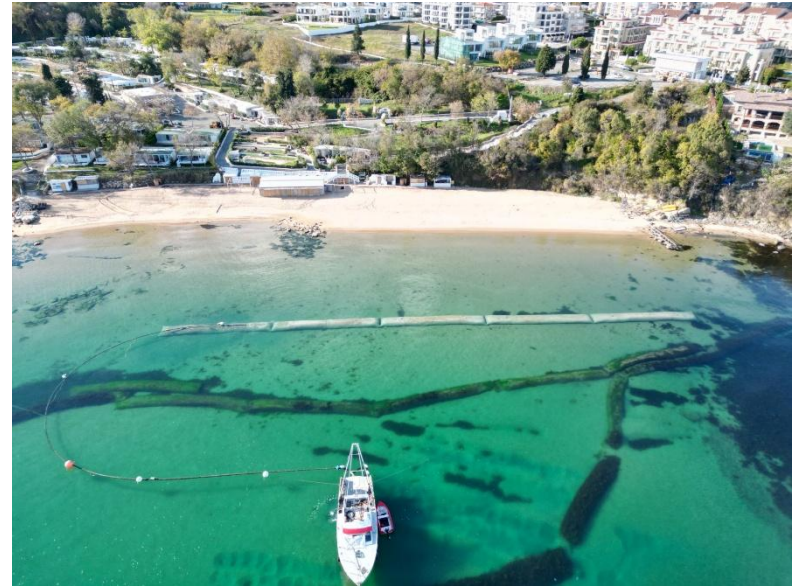

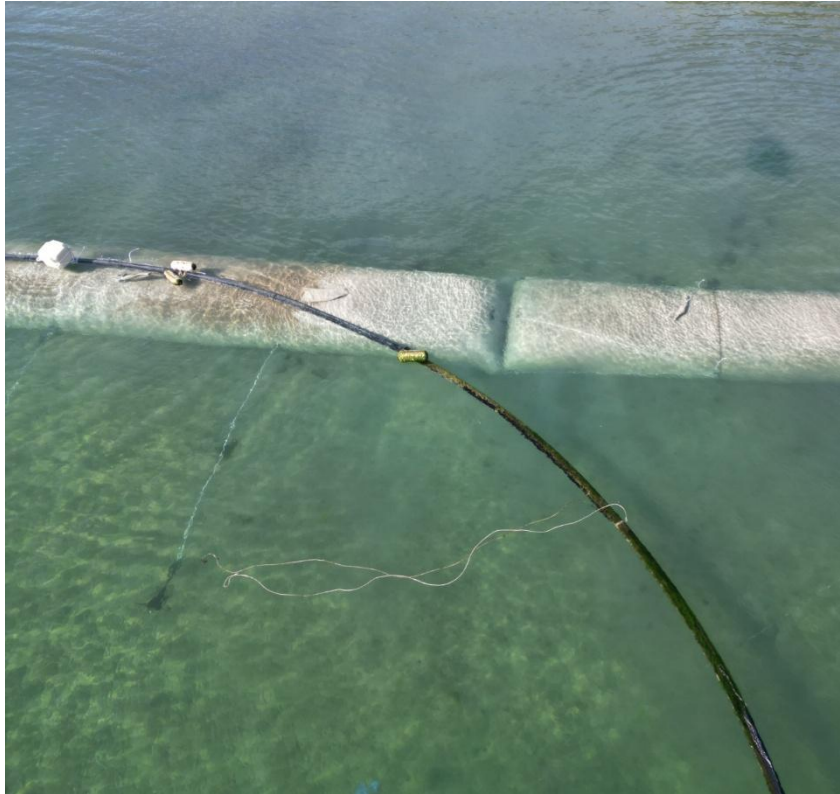

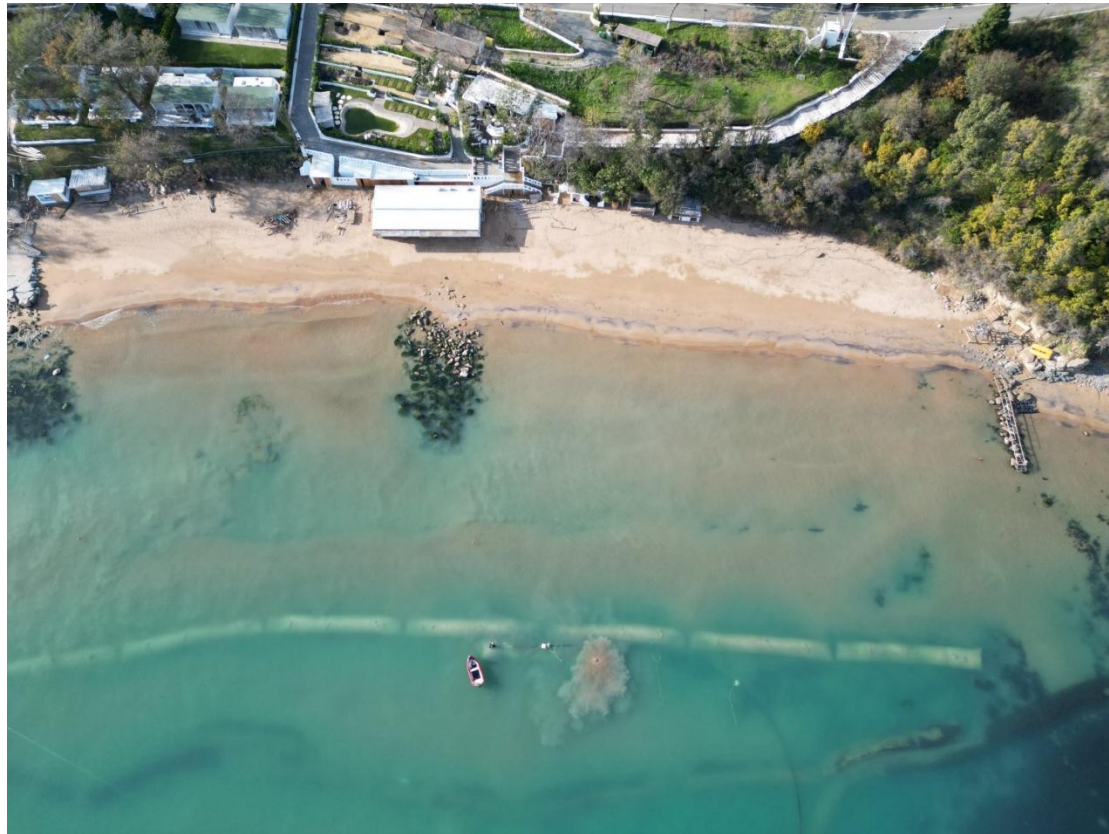

Why to use tubes and bags?

Benefits	Obstructions
No Rock! No metal (no corrosion)!	Vandalism.
Locally available materials (preferably sand or soil) can be used for filling.	Damage of the geotextile shell.
Flexible soft solution (especially bags are flexible and adaptive).	Durability concerns.
Filter stable constructions.	Acceptance of authorities, residents.
High installation output.	
Less transport traffic.	
Reduction of the carbon footprint (e.g. in comparison to a rock structure).	
Can be integrated into the environment with an eye pleasant appearance.	

SoilTain® Dewatering Tubes



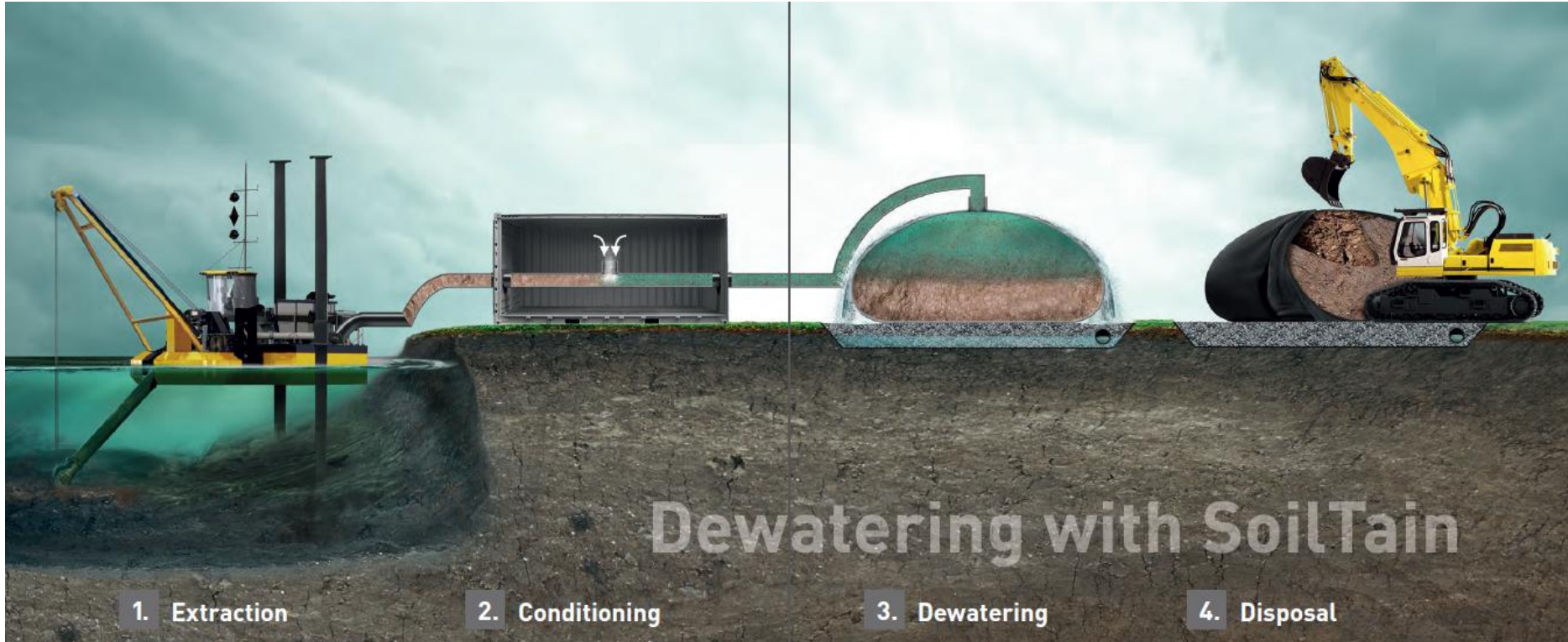

Inkwilersee, Switzerland, 2018



Dewatering tube in action (15 m circumference by a length of 35 m)



Dewatering field







Incomat[®]

Geosynthetic Concrete Mattresses



What is an Incomat mattress?

“Geotextile lost formwork”

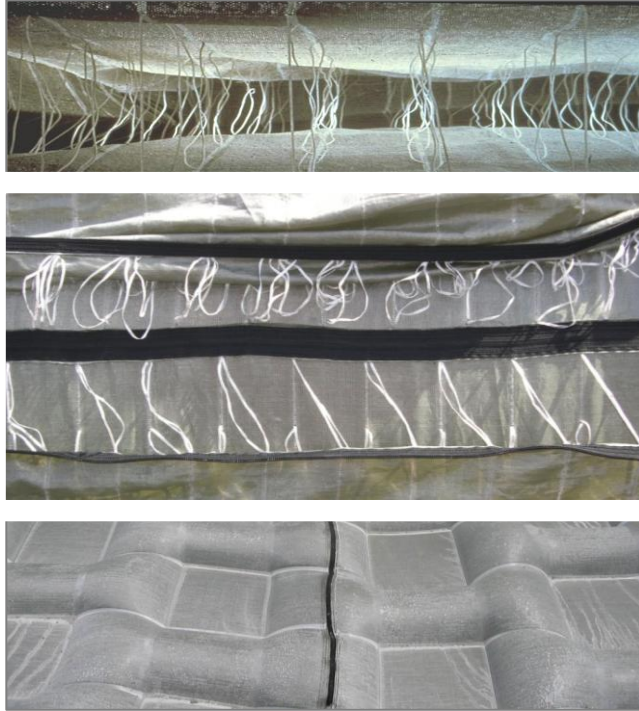

Concrete



+

Incomat Standard



State-of-the-art cover lining and erosion control with concrete mattresses.

Incomat Pipeline Cover



Efficient, quick-to-install system to protect pipelines against buoyancy, uplift and external impacts..

Incomat Flex



Permeable cushion mattress with built-in hinge zones, designed for high hydraulic loads and settlement-prone bases.

Incomat Filterpoint



The permeable concrete mat for use on stable subsoil and lower hydraulic loads.

Incomat Crib



The plantable concrete mat for erosion protection, ideally suited for shore protection above the permanent water level or for standing water bodies.

impermeable

permeable

Concrete requirements

- # Differences to standard concrete
 - # Grain size $\leq 8,00\text{mm}$
 - # Slump min 63 cm, better: SCC – **self compacting concrete**
 - # Liquid consistency acc. to SCC
 - # Strength is defined by the client



Incomat Standard filling (storm water pond)

Project Impressions



Project Impressions



Project Impressions



Project Impressions



Project Impressions



eco
LINE

100%
RECYCLED
PET



Perfect match of sustainability and durability

- # With our solutions even more sustainable construction is possible
- # Worlds first geotextiles in which the PET components consists of 100% recycled fibres
- # The recycled yarns used by us have proven original fibre quality



100 % original fibre quality from 100 % recycled PET



A world first' for more sustainable construction with geotextiles

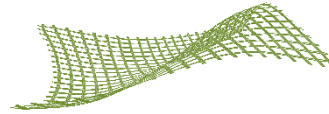

HUESKER product classics made of recycled PET



Less CO₂ emissions by using recycled yarn



Saving resources thanks to production with recycled PET bottles



PET recycled yarns with proven original fibre quality



Highest geotextile quality "Made in Germany"

CO₂ comparison - our recycled yarn vs. virgin yarn

Each kilogram of our PET recycling yarn saves approx. 4.3 kg CO₂ emissions compared to virgin yarn. This corresponds to a car journey of 33 km.

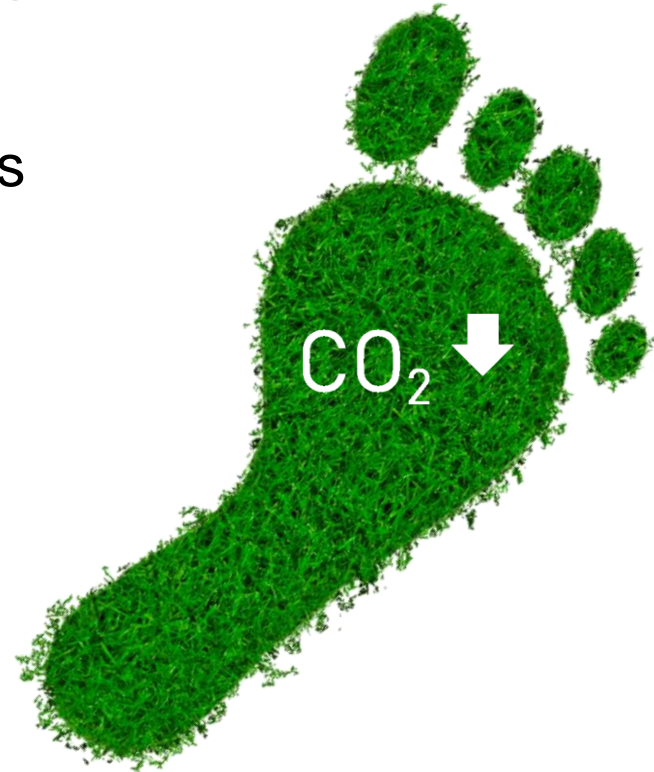

* Car with emissions of 130 g equiv. CO₂/km | Life Cycle Assessment Analysis von RDC Environment

CO₂ comparison - our recycled yarn vs. virgin yarn

Extrapolated to the production of geotextiles the size of a football pitch (7,140 m²), about 5,500 kg of CO₂ are saved, which corresponds to a distance of approx. 42,400 km by car.



* Car with emissions of 130 g equiv. CO₂/km | Life Cycle Assessment Analysis von RDC Environment | Calculated with HaTelit C 40/17 and approx. 180 g/m² PET yarn



bio
LINE

Natural. Biodegradable. Visionary.



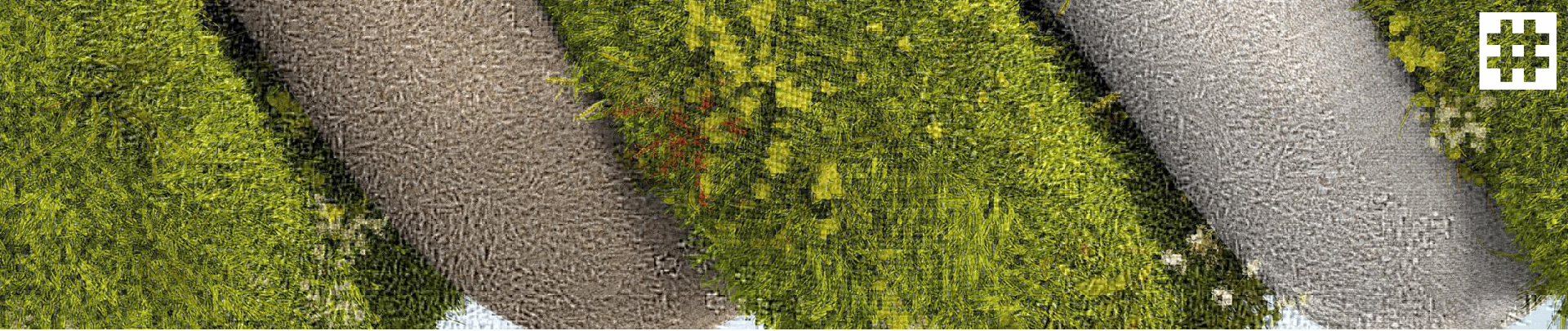

The products at a glance



Current ongoing Trials at the North and East Sea



Usage of 100 % biological and biodegradable materials.



First Plantings of a textile based composite with See grass



More layers and structure of structure of sand as filler.

Seagrasses play a significant role in capturing and storing carbon dioxide (CO₂), acting as a "blue carbon" in the ocean. They absorb CO₂ from the water through photosynthesis and storing them in the sediment below. This process helps mitigate climate change by reducing the amount of CO₂ in the atmosphere 30times faster than a rainforest on land would do.

Questions?



DI Thomas Hasslacher
hasslacher@huesker.com

Interreg



Co-funded by
the European Union



NEXT Black Sea Basin

EfxINNOs: ML in Image Processing and Object Recognition



ΔΗΜΟΚΡΙΤΕΙΟ
ΠΑΝΕΠΙΣΤΗΜΙΟ
ΘΡΑΚΗΣ

DEMOCRITUS
UNIVERSITY
OF THRACE

Fenia Psomouli,
Research Assistant
Democritus University of Thrace

03 July 2025, Kavala



Presentation overview

- Introduction
- Technology platform and data collection
- Role of Machine Learning in the project
- Why object detection?
- YOLO algorithm
- Object detection workflow
- Preprocessing of raw sonar data
- Example outputs
- Challenges
- Future vision

Introduction

Machine learning is a branch of Artificial Intelligence that focuses on enabling computers to:

- imitate the way that humans learn
- perform tasks autonomously
- improve their performance and accuracy through experience and exposure to more data.

In the context of marine ecosystem monitoring, ML can help automate detection of seafloor objects, support large-scale mapping, and enable more informed environmental decision-making.

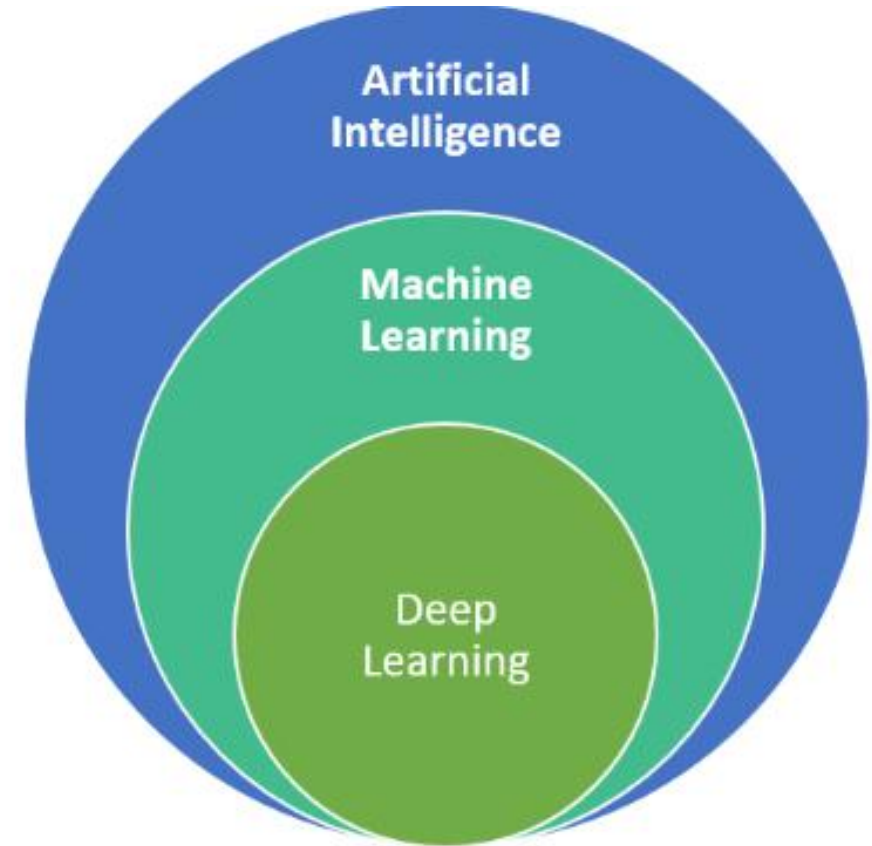

Technology platform and data collection

RTSYS NEMOSENS mAUV equipped with:

- CTD: salinity and temperature data
- Camera: RGB videos and images
- Side Scan Sonar: acoustic images



Role of Machine Learning in the project

- **Automating data processing at scale**
 - ML models (e.g YOLO) can process thousands of images without human supervision which means that they can handle massive volumes of data
- **Repeatability and standardization**
 - ML models (e.g YOLO) apply consistent rules across datasets, promote data harmonization across different projects and partners which makes it easy to compare sites and results
- **Expanding monitoring capacities and introduces scalability**
 - By applying the same methodology to different areas

Who will benefit?

- Researchers, policy makers, local authorities
- Educational institutions

Why object detection?

- **Well suited for discrete object identification**
 - Works great for detecting individual, recognizable objects (anchors, litter, seagrass patches, pipelines, underwater cables)
- **Compatible with sonar's visual characteristics**
 - Acoustic patterns are learnable by algorithms like YOLO due to the different signal signature of different objects
- **Scalable and efficient**
 - Object detection models like YOLO process a lot of images quickly therefore are ideal for handling the large data volume from multi-day surveys
- **Easy mapping**
 - Detected bounding boxes can be converted into shapefiles

What is YOLO (You Only Look Once)?

- A real-time object detection algorithm
- Detects what objects are present in an image and where they are using bounding boxes and class labels

How does it work?

- Input image is divided into an $S \times S$ grid
- Each grid cell predicts:
 - Bounding boxes
 - Confidence score
 - Class probabilities
- All predictions are made in one forward pass through the network

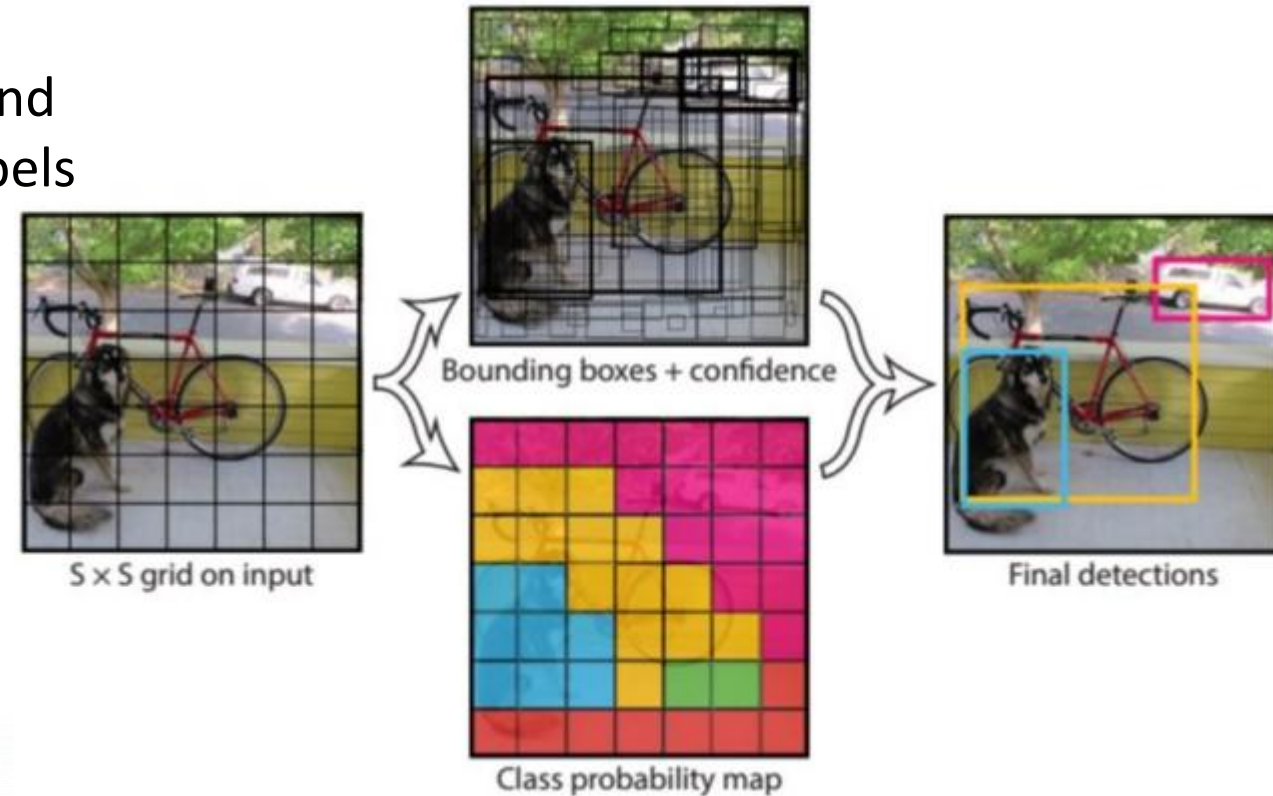

Why YOLO?

- **Real time detection:** useful for processing a lot of AUV images and videos quickly
- **Single-pass architecture:** fast and efficient
- **Works well on cluttered scenes:** detects multiple objects even in dense seafloor environments
- **Transfer learning:** can be fine-tuned with underwater datasets

Object detection workflow

Object detection using YOLO

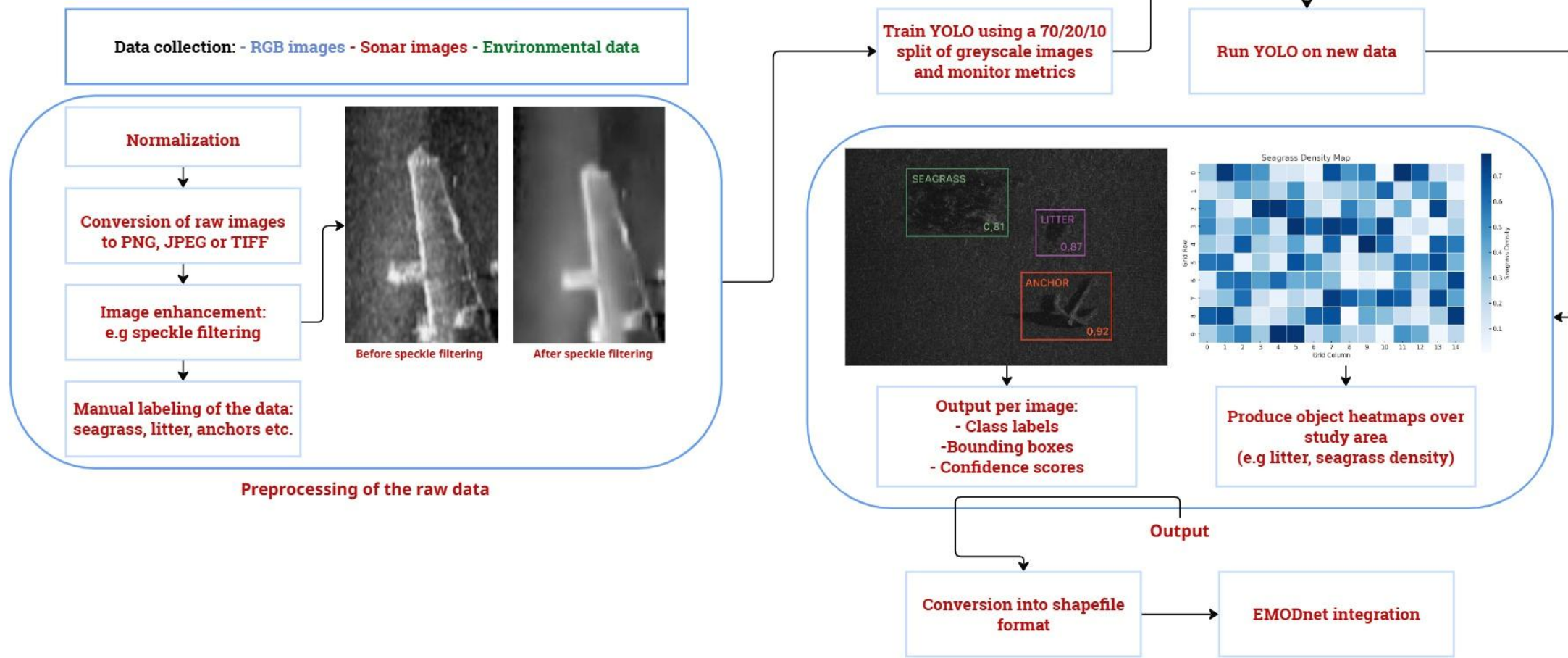

Preprocessing of raw sonar data

Object detection using YOLO

Data collection: - RGB images - Sonar images - Environmental data

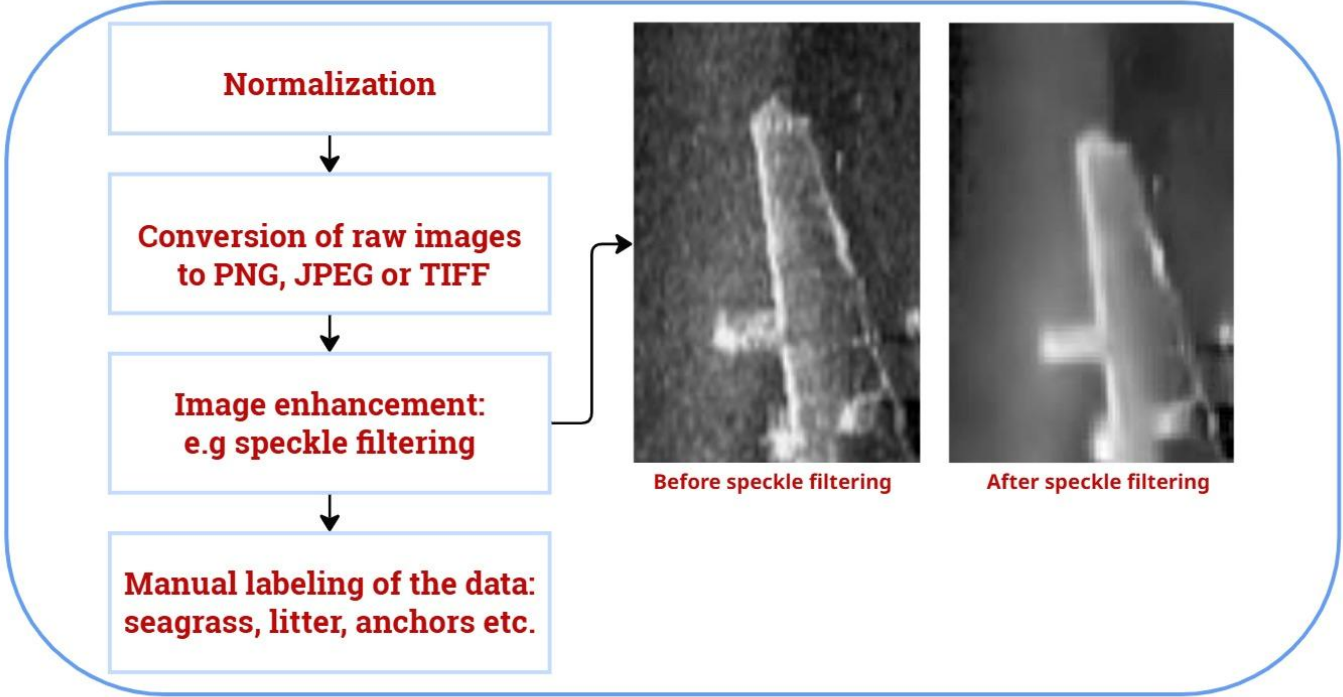

Preprocessing of the raw data

Example outputs

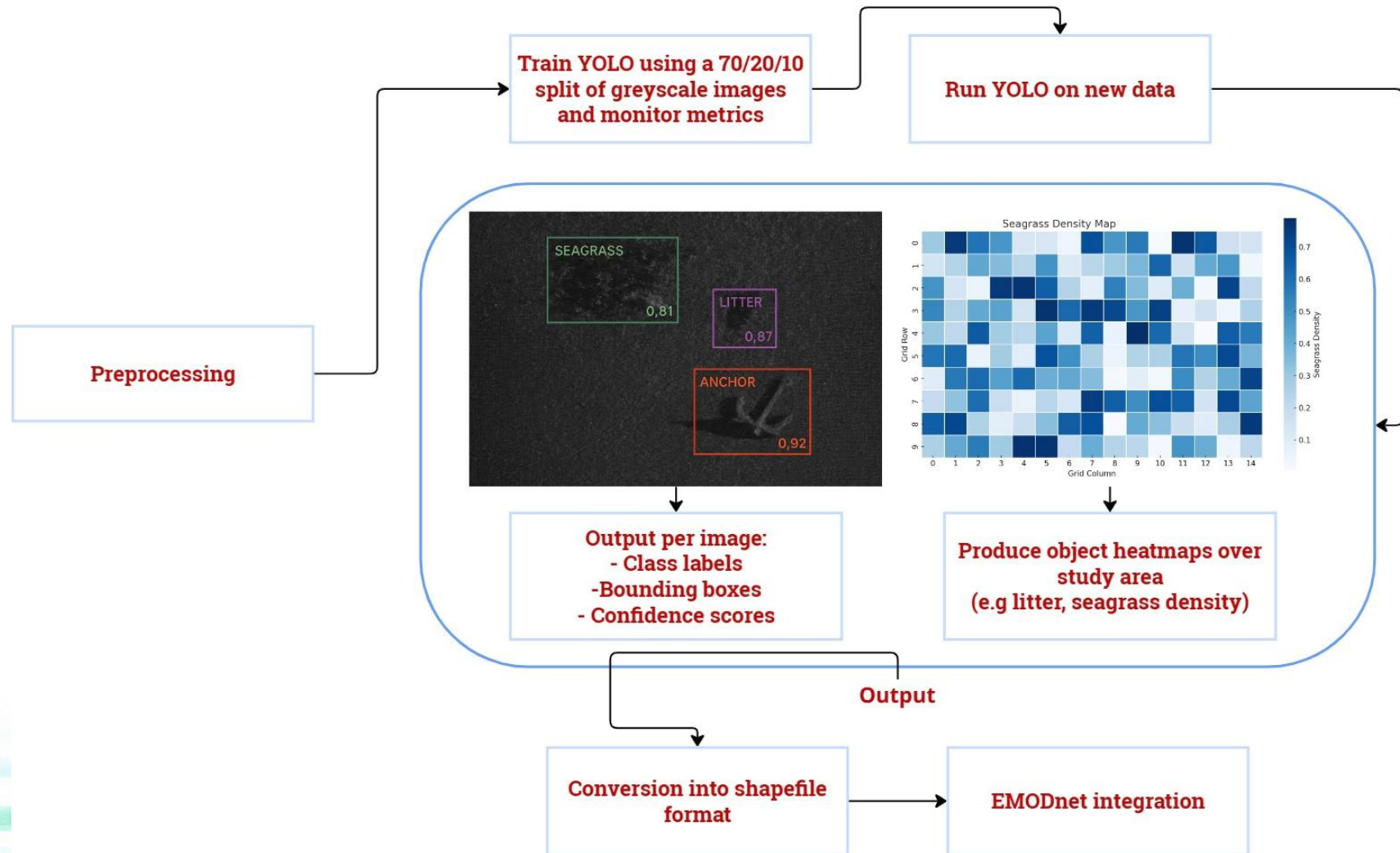

Challenges

- **Nature of sonar data:** objects might appear distorted due to sonar angle or range
- **Detecting litter:** it varies widely in shape, size and material (metal, plastic etc) therefore acoustic signatures may be subtle or inconsistent
- **Detecting seagrass:** often blends with surrounding sediment and may lack sharp boundaries
- **Difficulty in creating an annotated dataset**
- **Restricted visibility:** suspended particles lower the visibility making it challenging to detect and identify objects
- **Environmental conditions:** strong currents make the field part of the process more difficult

Future vision – Expanding marine monitoring

- Fusion of multi-modal data
 - Combine visual data (RGB images), acoustic data (sonar) and environmental data (CTD: salinity, temperature) and build ML models that integrate:
 - Object detections from cameras and sonar
 - Habitat and health indicators from environmental data
- Move toward near real-time processing for responsive conservation action
- Use ML to correlate environmental conditions with seagrass health
- Train models to forecast habitat degradation based on CTD anomalies or spatial patterns in litter
- Harmonize ML workflows across counties
- Share models and training datasets
- Expansion beyond the North Aegean Sea

Interreg



Co-funded by
the European Union



NEXT Black Sea Basin



Interreg



Co-funded by
the European Union



NEXT Black Sea Basin

Data Processing and Introduction to data processing software



ΔΗΜΟΚΡΙΤΕΙΟ
ΠΑΝΕΠΙΣΤΗΜΙΟ
ΘΡΑΚΗΣ

DEMOCRITUS
UNIVERSITY
OF THRACE

Nikolaos Kokkos, DUTH

03 July 2025, Kavala

Side-scan sonars

The Side Scan Sonar (SSS) is an acoustic reflection technology. **Basically, they use a swath of sound** to survey the seafloor.

Side-scan sonars **emit conical or fan-shaped pulses across a wide angle** perpendicular to the path of their towed sensors ('towfish' or 'rail') and record the echoes.

The received signals (echoes) create a detailed image of the **seafloor's reflectivity and its anomalies** ('sonograph') within the beam's swath (coverage range). The travel time and intensity of the returned pulse are recorded.

The **reflectivity** of the seafloor **depends on its roughness** and the nature of the topmost material:

- coarse-grain sediments display higher reflectivity than fine-grain deposits,
- rocky outcrops reflect higher than sediments, etc.

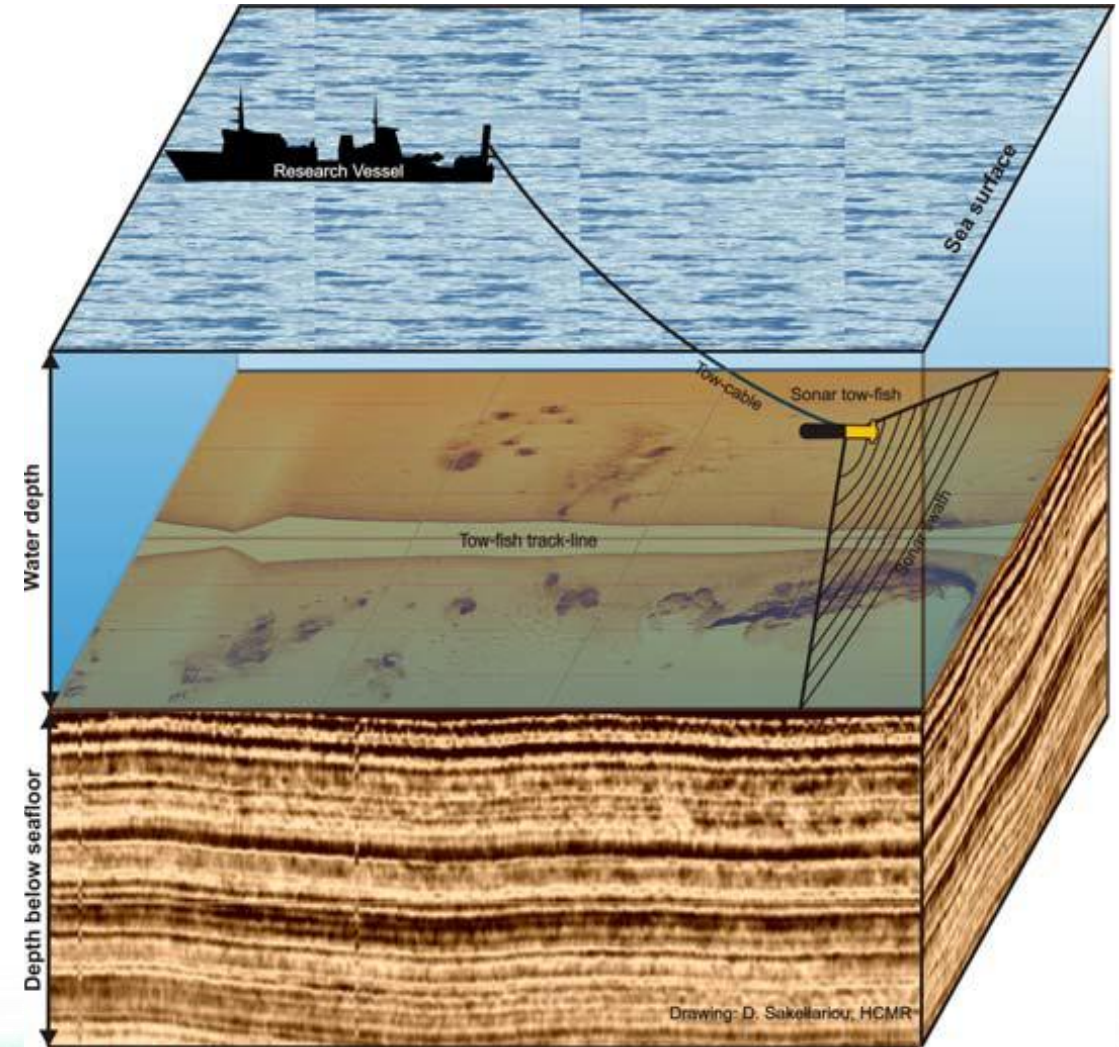

Side-scan sonars – Range of detection

The **lower 200 kHz** frequency side scan sonar is capable of detecting large targets at **ranges of 150 meters**.

The **higher 455 kHz** frequency side scan sonar **has a narrow beam** and **shorter (100m) range** for **more detailed** images of closer targets.

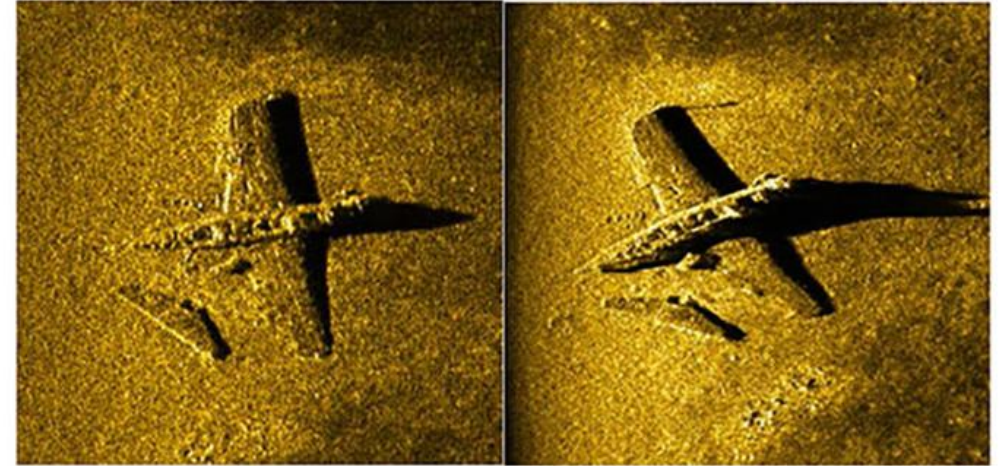
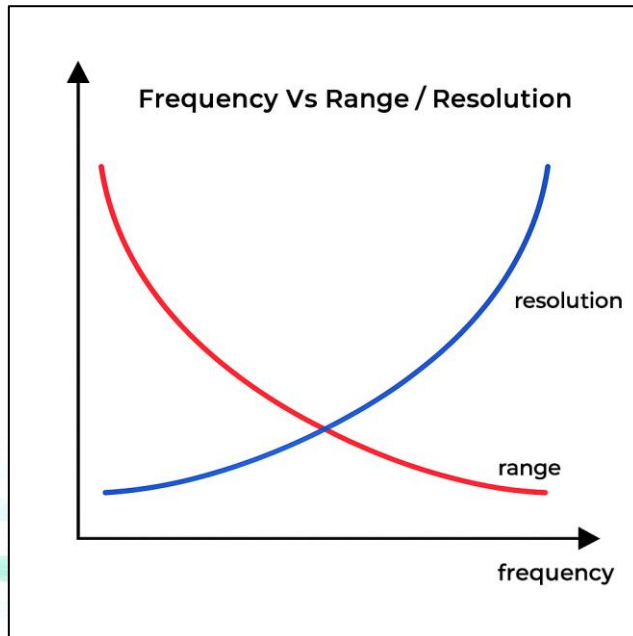

400 KHz

600 kHz

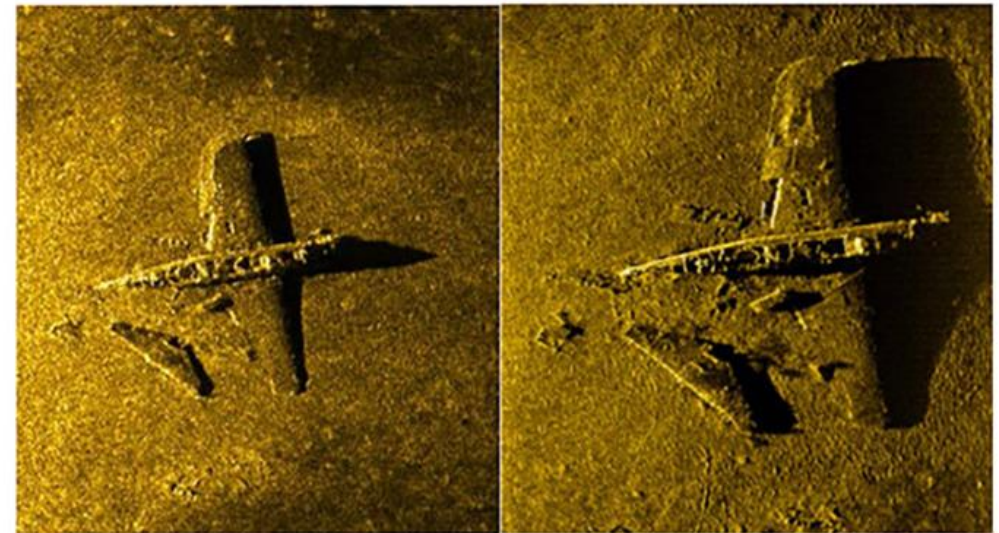

900 kHz

1600 kHz

Side-scan sonars – StarFish 454 OEM



	StarFish 454 OEM
Frequency	450kHz CHIRP
Operating Range	Up to 100m per channel
Horizontal Beam Width	0.5°
Vertical Beam Width	60°
Transducer Angle	Variable (OEM Specified)
Dimensions	390mm x 22.5mm x 40mm
Weight (In Air)	0.8kg
Construction	Polyurethane Rubber (PA6 Housing)
Colour	Black

Side-scan sonars – Acoustic shadow

Using a side scan sonar is rather like **looking at a world made of shiny black plastic, in the dark, with only a narrow torch beam for illumination.**

It can be the most important sonar imagery feature as **it provides a three-dimensional quality** to a two-dimensional survey.

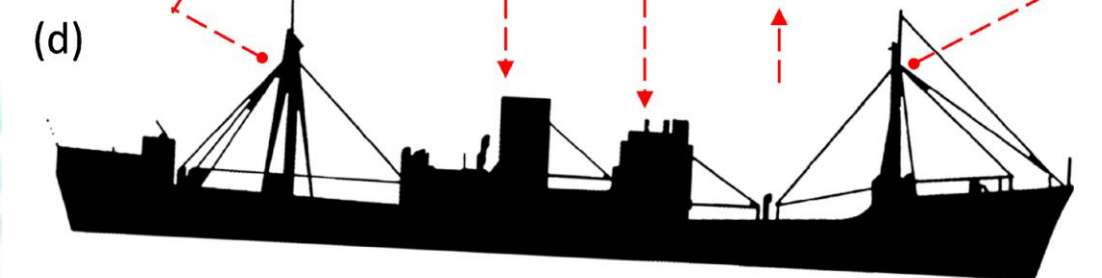
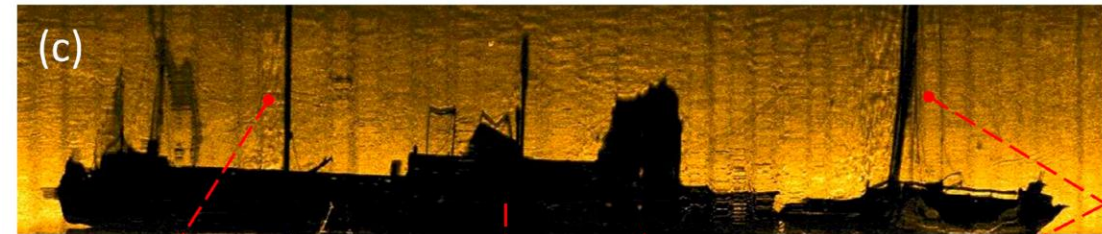
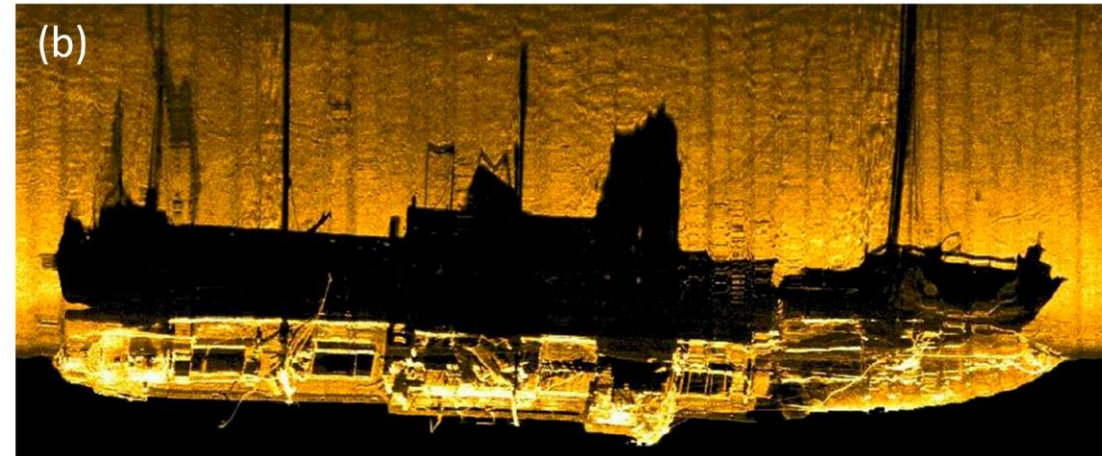
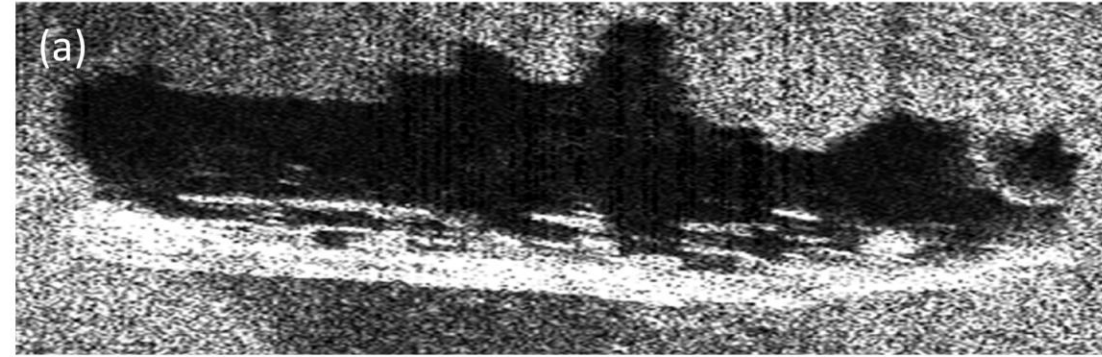
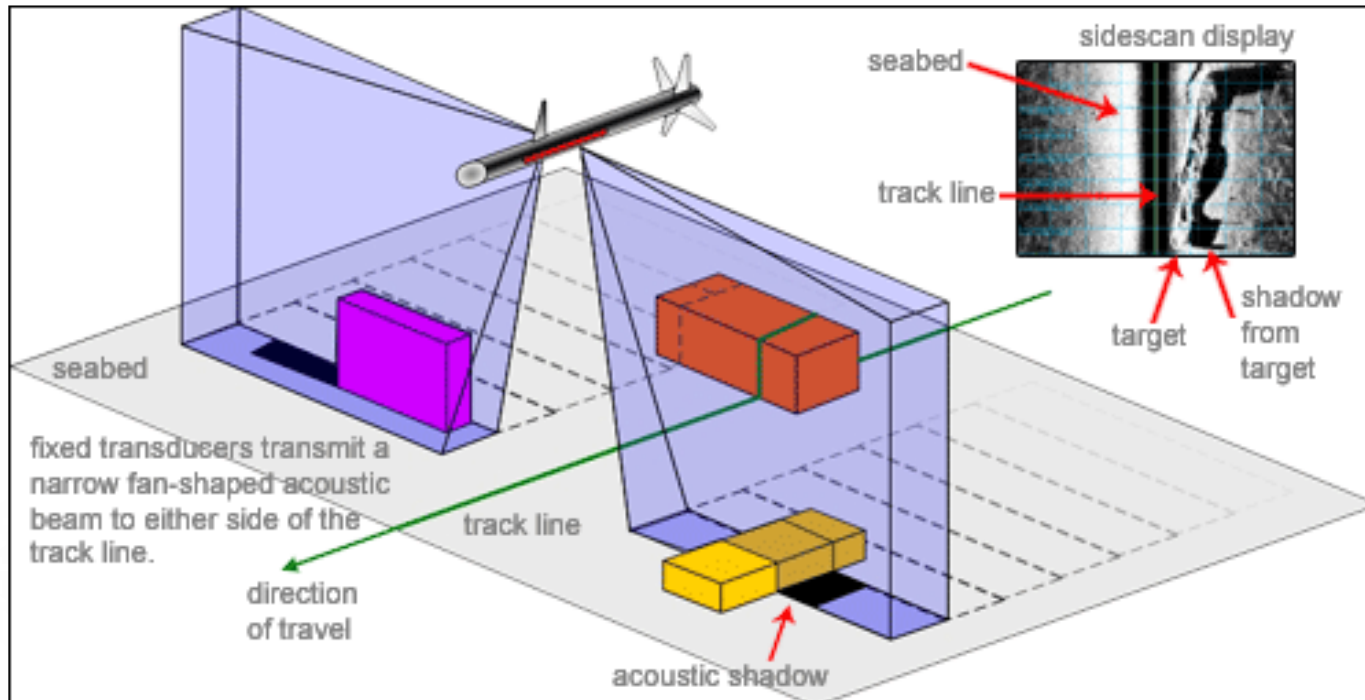

Side-scan sonars – Nadir line

Side-scan sonars **measure the sum of all returns to calculate the location of targets.**

The **nadir zone** is the area **directly below the towfish**, just to the left and to the right of the towfish making up approximately 5% of the range scale.

At nadir, all returns have an incident angle close to 90° , and as a result, there is negligible time difference between each return, making it impossible to discriminate them. **It creates a blind spot in the nadir area.**

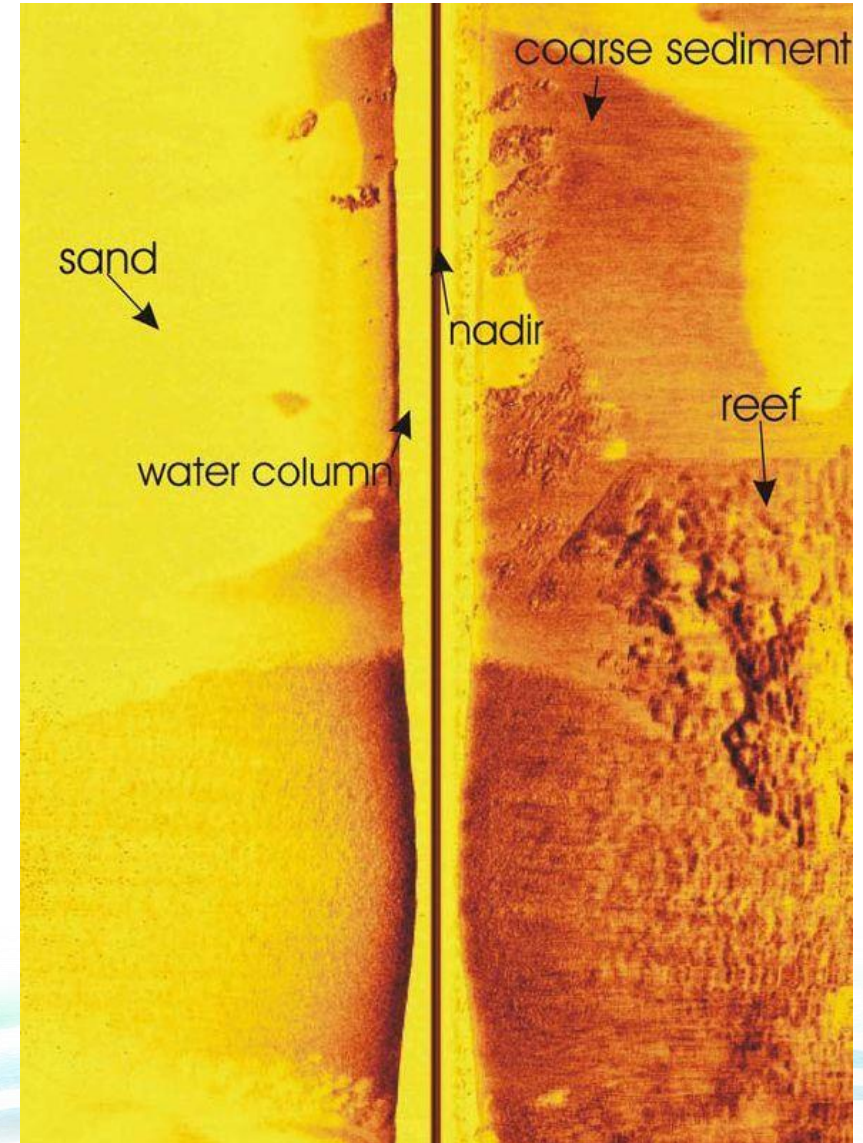
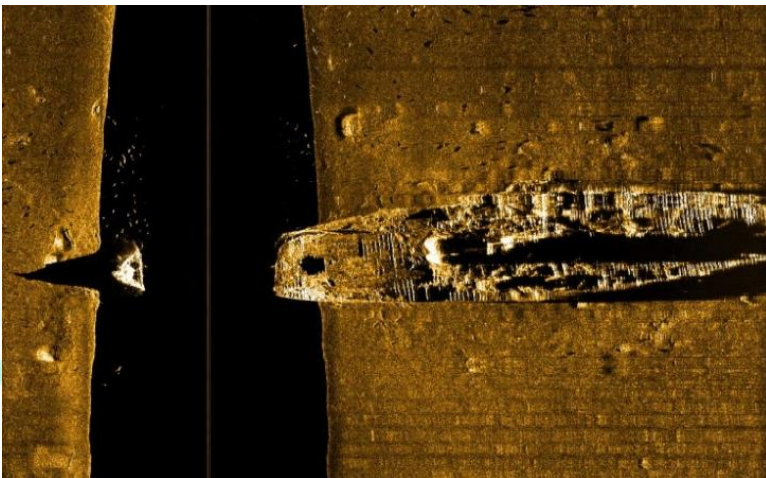

eXtended Triton Format (XTF) files

An XTF file can be thought of as a “pool” of data.

If you use XTF to collect data during a survey, you can add data to the file at any time without needing to synchronize your data packets.

For example:

- bathymetry data may be logged five times per second
- sonar data is being logged at 10 times per second.

No storage space is wasted and no “holes” are created in the saved data stream.

XTF file structure

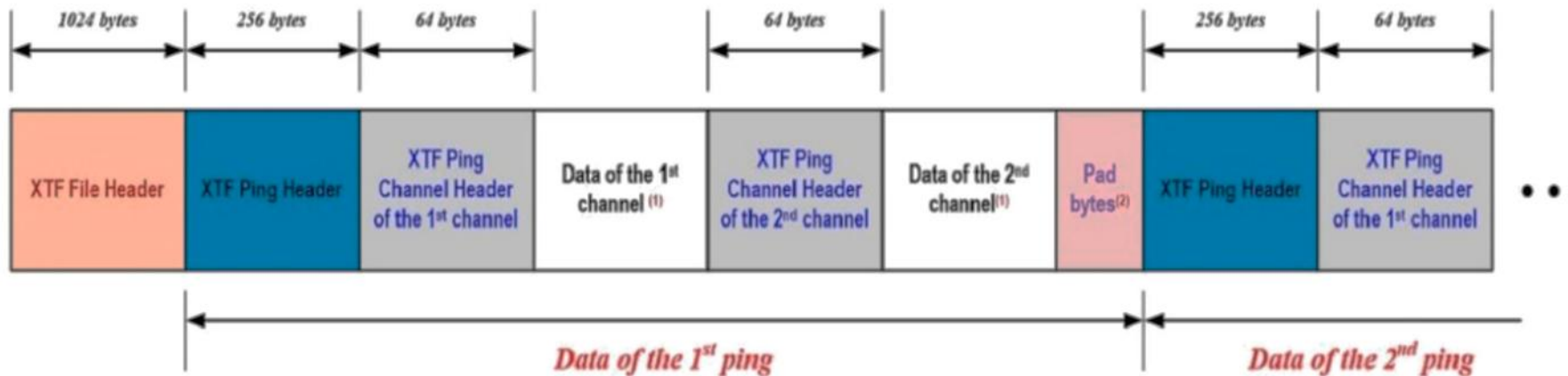

Triton Imaging, Inc (1988)

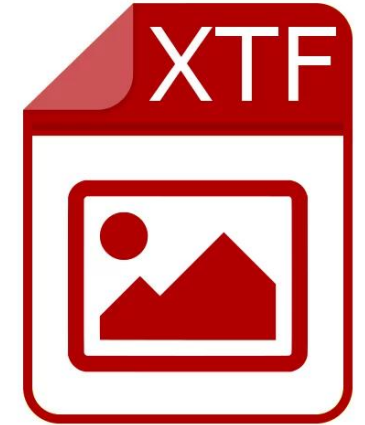

SONARWIZ

Developed by **Chesapeake Technology**, is an all-in-one software solution for geophysical, hydrographic, pipeline, and archaeological marine surveys.

- real-time data acquisition
- post-processing
 - sidescan,
 - sub-bottom,
 - bathymetry, and
 - magnetometry data

ReefMaster



Developed by **ReefMaster Software**, is a Windows-based software.

- Track and depth log import
- Real-time mapping
- Sidescan mosaic creation
- Waypoint and route management
- Export to GPS

BSB00193 - EfxINNOs



OpenSideScan



CIDCO

Developed by **CIDCO**. Open-source software for:

- processing and
- visualizing sidescan sonar data

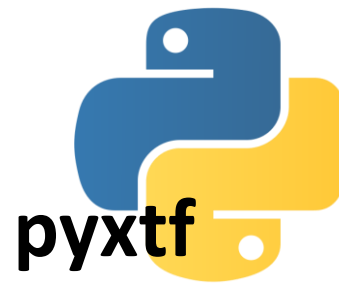

Developed by **Oystein Sture (oysstu)**, is a Python library for reading and writing eXtended Triton Format (XTF) files.

- Read and parse XTF files (file headers & sonar/sub-bottom/bathymetry packets)
- Write or generate XTF files
- Support for reading multiple data packet types (navigation, ping, attitude, etc.)

Developed by **Chesapeake Technology**, is an all-in-one software solution for geophysical, hydrographic, pipeline, and archaeological marine surveys.

Sidescan

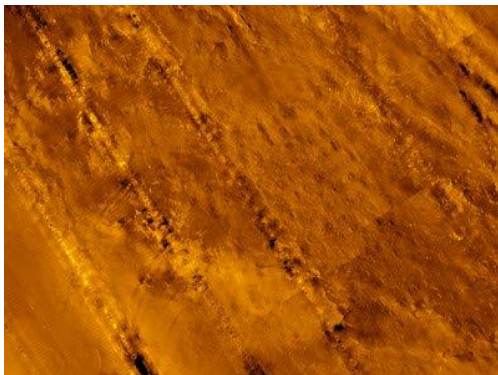

Sub-Bottom

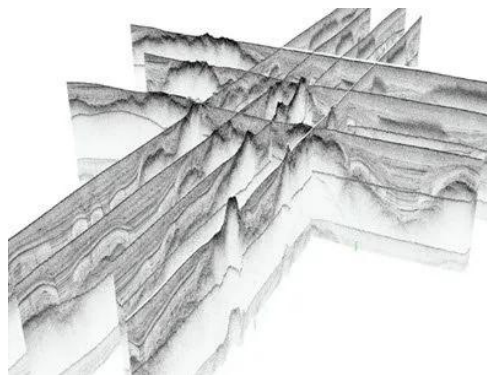

Magnetometry

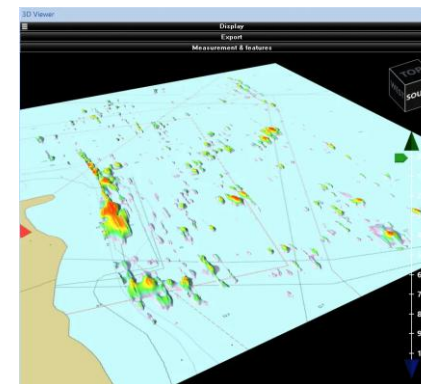

Single beam

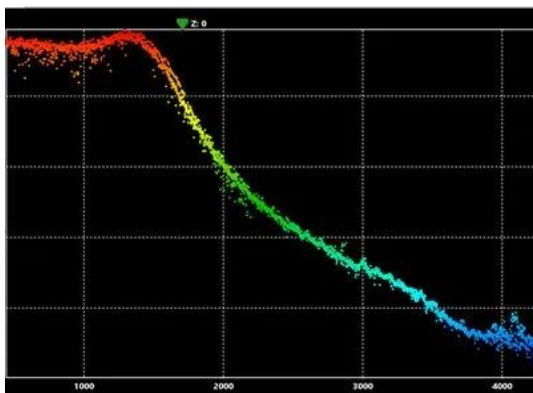

Multi-beam

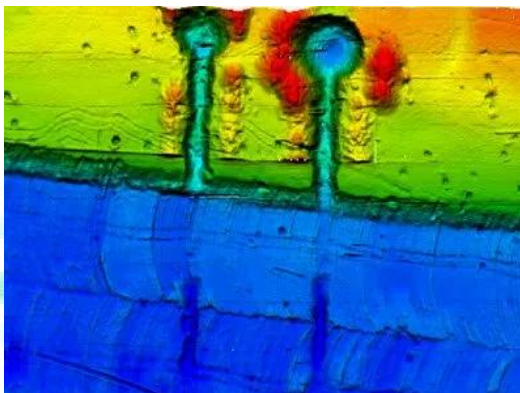

<https://chesapeaketech.com/products/sonarwiz-sidescan/>





Main view

The screenshot shows the main interface of the SonarWiz software. At the top, there is a menu bar with options: Data Acquisition, Post Processing, Maps, View, Tools, and Help. Below the menu bar is a toolbar with various icons for sensor graphs, toolbars, layout manager, data displays, map display, color and contrast, and control. The main area is a large black rectangle, likely representing the sonar data display. On the left side, there is a 'System Information' panel with the following details:

- Version: SonarWiz 5 V5.03.0009
- License: SN:21845 UID:12336 R/T
- User: Bandura Vladimir
- State: Idle
- Project: Perama
- Geodesy: UTM84-35N

Below the system information, there is a section for real-time data:

- System Time: 06/18/25 13:21:34
- SSS Ping Number:
- Ship Latitude:
- Ship Longitude:
- Ship Northing:
- Ship Easting:
- Ship Speed: 0.00
- Ship Heading: 0.00
- Ship Course: 0.00
- Water Depth (m): 0.00

At the bottom of the window, there is a status bar showing coordinates: 47° 39.3887' N 003° 26.6439' W X:-1772048.0 Y:5746724.5 Z:0.0



Project creation

Create
a new
project

System Information

Version: SonarWiz 5 V5.03.0009
License: SN:21845 UID:12336 R/T
User: Bandura Vladimir
State: Idle
Project: Perama
Geodesy: UTM84-35N

System Time: 06/18/25 13:21:34
SSS Ping Number:
Ship Latitude:
Ship Longitude:
Ship Northing:
Ship Easting:
Ship Speed: 0.00
Ship Heading: 0.00
Ship Course: 0.00
Water Depth (m): 0.00

Create a New Project...

Vessel Name: RTSYS [OK] [Cancel]

Project Name: Efxinnos [Browse...]

Project: C:\Users\niko\Desktop\Efxinnos\RTSYS\Presentation\Soi [Browse...]

Approximate Project Position

Latitude: 47° 40.01923' N [Use GPS Position] [Get From File..] [Select from World Cities]

Longitude: 003° 27.46481' W

Coordinate Source

Auto (Use fish if valid, otherwise use ship) [Time Constant for Course Smoothing: 300 pings.]

Always Use Fish Position

Always Use Ship Position

Coordinate System

UTM84-30N [EPSON Code: ???] Automatically Select Coordinate System

UTM-WGS 1984 datum, Zone 30 North, Meter, Cent Meridian 3d W [Browse Coordinate Systems...]

47° 39.3887' N 003° 26.6439' W X:-1772048.0 Y:5746724.5 Z:0.0



Import files

The screenshot displays the SONARWIZ software interface. The main menu bar includes 'Data Acquisition', 'Post Processing', 'Maps', 'View', 'Tools', and 'Help'. The 'Post Processing' menu is open, showing options like 'AGC', 'BAC', 'UGC', 'Bottom Track...', 'Digitizing View...', 'Nadir Transparency', 'Order', and 'Navigation...'. The 'Import' option is highlighted, and a sub-menu is visible with 'Sidescan Files...', 'Sub-bottom Files...', and 'Magnetometer'. The 'Import Sidescan Sonar Files (Ctrl+I)' option is selected, with a tooltip that reads: 'Import sidescan sonar files in many different formats into this project. Note: Select only files that were collected in the area of your current project position.'

On the left side, there is a status panel with the following information:

- License: SN21845
- User: Bandura Vlad
- State: Idle
- Project: Efxinnos
- Geodesy: UTM84-30N

Below the status panel, system and vessel data is displayed:

- System Time: 06/18/25 13:24:06
- SSS Ping Number:
- Ship Latitude:
- Ship Longitude:
- Ship Northing:
- Ship Easting:
- Ship Speed: 0.00
- Ship Heading: 0.00
- Ship Course: 0.00
- Water Depth (m): 0.00

The main workspace shows a grid of coordinates. The bottom status bar displays: 47° 40.5554' N 003° 27.6398' W X:465421.9 Y:5280384.3 Z:0.0

Import files

System Information

Version: SonarWiz 5 V5.03.0009
License: SN:21845 UID:12336 R/T
User: Bandura Vladimir
State: Idle
Project: Efxinnos
Geodesy: UTM84-30N

System Time: 06/18/25 17:24:53
SSS Ping Number:
Ship Latitude:
Ship Longitude:
Ship Northing:
Ship Easting:
Ship Speed: 0.00
Ship Heading: 0.00
Ship Course: 0.00
Water Depth (m): 0.00

Name	Date modified	Type
20240326_135937_RTSYS_001.xtf	24/3/2025 9:56 μμ	Extended T
20240326_141134_RTSYS_002.xtf	20/3/2025 3:19 μμ	Extended T
20240326_142330_RTSYS_003.xtf	20/3/2025 3:19 μμ	Extended T

Import Instructions

Aggregate Number to: 10

No Gain Custom Gain: 1.0 Auto TVG

Split Time Gaps Occur Channels: Channels 1 and 2

Geodesy: UTM-WGS 1984 datum, Zone 10 North, Meter; Cent. Meridian 123d W

Navigation data in XY or grid format.

uncheck this

Project folder

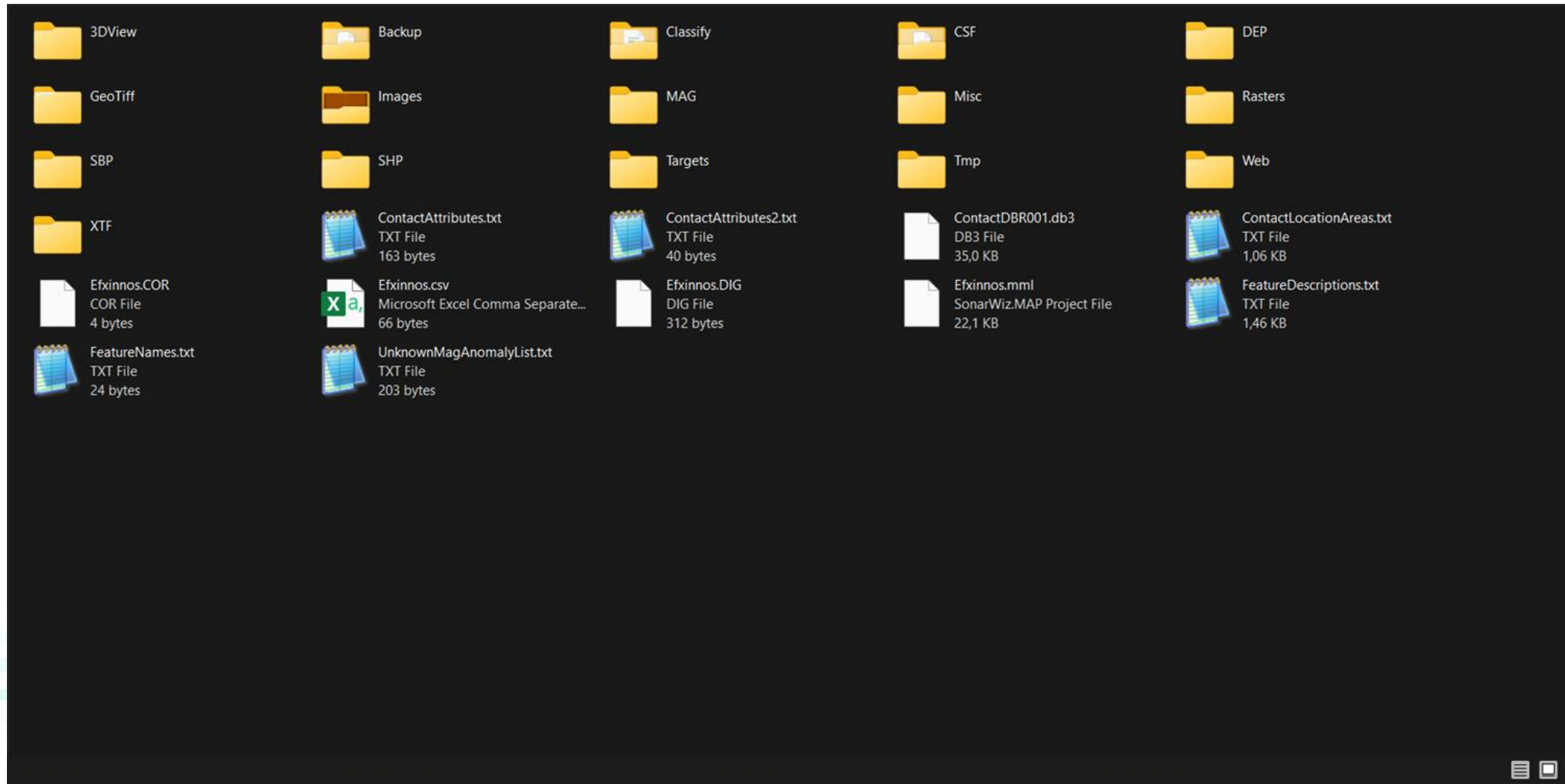



Import files

The screenshot displays the SonarWiz software interface. The main window shows a map with a white polygon overlaid on a grid. The interface includes a menu bar (Data Acquisition, Post Processing, Maps, View, Tools, Help) and a toolbar with various icons for file operations and processing. A System Information panel on the left provides details about the software version, license, user, project, and geodesy. The status bar at the bottom shows the current coordinates and zoom level.

System Information

- Version: SonarWiz 5 V5.03.0009
- License: SN:21845 UID:12336 R/T
- User: Bandura Vladimir
- State: Idle
- Project: Efxinnos
- Geodesy: UTM84-30N

System Time: 06/18/25 13:29:11

- SSS Ping Number:
- Ship Latitude:
- Ship Longitude:
- Ship Northing:
- Ship Easting:
- Ship Speed: 0.00
- Ship Heading: 0.00
- Ship Course: 0.00
- Water Depth (m): 0.00

Status Bar: 47° 39.9645' N 003° 27.5371' W X:465543.9 Y:5279289.1 Z:0.0

Aggregation

The screenshot shows the SonarWiz software interface with the Sonar File Manager dialog box open. The dialog box displays project information and a list of files. A red arrow points to the 'Aggregate' button in the right-hand menu.

System Information:

- Version: SonarWiz 5 V5.03.0009
- License: SN:21845 UID:12336 R/T
- User: Bandura Vladimir
- State: Idle
- Project: Efxinnos
- Geodesy: UTM84-30N

System Time: 06/18/25 13:29:11

SSS Ping Number:

Ship Latitude:

Ship Longitude:

Ship Northing:

Ship Easting:

Ship Speed: 0.00

Ship Heading: 0.00

Ship Course: 0.00

Water Depth (m): 0.00

Sonar File Manager:

Project: C:\Users\nikol\Desktop\Efxinnos\RTSYS\Presentation\Sonarwiz\Efxinnos.mml

Number of Files in Project: 3 Number of Files Enabled: 3

Limits of All Files			Limits of Enabled Files				
	Minimum:	Maximum:	Range:		Minimum:	Maximum:	Range:
X:	465020	465684	664	X:	465020	465684	664
Y:	5279039	5279439	400	Y:	5279039	5279439	400

<input checked="" type="checkbox"/>	Enable	File Name	Size	<input type="checkbox"/>	AGC	<input type="checkbox"/>	UGC
<input checked="" type="checkbox"/>	<input checked="" type="checkbox"/>	C:\Users\nikol\Desktop\Efxinnos\RTSYS\Presentation\Sonarwiz\CSF\20240326_141134_RTSYS_002.CSF	23280 KB	<input type="checkbox"/>	<input type="checkbox"/>	<input type="checkbox"/>	<input type="checkbox"/>
<input checked="" type="checkbox"/>	<input checked="" type="checkbox"/>	C:\Users\nikol\Desktop\Efxinnos\RTSYS\Presentation\Sonarwiz\CSF\20240326_142330_RTSYS_003.CSF	2301 KB	<input type="checkbox"/>	<input type="checkbox"/>	<input type="checkbox"/>	<input type="checkbox"/>
<input checked="" type="checkbox"/>	<input checked="" type="checkbox"/>	C:\Users\nikol\Desktop\Efxinnos\RTSYS\Presentation\Sonarwiz\CSF\20240326_135937_RTSYS_001.CSF	23280 KB	<input type="checkbox"/>	<input type="checkbox"/>	<input type="checkbox"/>	<input type="checkbox"/>

Right-hand menu:

- OK
- Cancel
- Sheave Offset...
- Batch Image Export...
- Batch Bottom Track...
- Make Like Selected...
- Aggregate**
- Bottom Track...
- Digitizer View
- Navigation...
- Properties...
- Settings...
- Report...
- Coverage...
- Set Cable Out...
- Offset Cable Out...
- Set Sensor Depth...
- Import Bottom Track

Bottom Track

The screenshot displays the SonarWiz software interface. The main window shows a sonar scan with a blue line representing the bottom track. A dialog box titled "Processing: C:\Users\niko\Desktop\Efxinnos\RTSYS\Presentation\Sonarwiz\20240326_135937_RTSYS_001-to-20240326_142330_RTSYS_003.csf" is open, showing various control options for channel control, visual control, manual tracking, and auto tracking. The auto tracking section includes a "Track It" button and a "Smooth" checkbox. The system information panel on the left provides details about the software version, license, user, and system time.

System Information:

- Version: SonarWiz 5 V5.03.0009
- License: SN:21845 UID:12336 R/T
- User: Bandura Vladimir
- State: Idle
- Project: Efxinnos
- Geodesy: UTM84-30N

System Time: 06/18/25 18:16:27

SSS Ping Number:

Ship Latitude:

Ship Longitude:

Ship Northing:

Ship Easting:

Ship Speed: 0.00

Ship Heading: 0.00

Ship Course: 0.00

Water Depth (m): 0.00

Processing Dialog Box:

- Channel Control: Port, Stbd
- Visual Control: Gamma Correct, Histo Equalize, Normalize, Copy to Clipboard
- Manual Tracking: Insert Points, Remove Points, Clear All, Offset Alt., Auto Scroll
- Auto Tracking: Blanking: 10, Duration: 0, Threshold: 87, Track It, Smooth
- Buttons: Save, Save & Next, Cancel

Processing Data Table:

03/26/2024 13:59:50	
Ping: 187	CBL:0.00 (m)
47 40.01802' N	N:5279387.28
003' 27.42732' W	E:465681.90
HDG:191.56	CMG:180.94
RNG: 43.7 METER	
EVT:190.00	WDEP:0.0 SDEP:3.9

System Tray: CTI Support, Redraw, 47° 39.8797' N 003° 27.5630' W X:465510.6 Y:5279132.2 Z:0.0

Sidescan Gain and Signal Processing

Sound **cannot propagate uniformly in all directions** from a source in the ocean forever.

Beyond some range the **sound will hit the sea surface or sea floor**.

Once the **sound is trapped between the top and bottom of the ocean** it gradually begins to **spread cylindrically**.

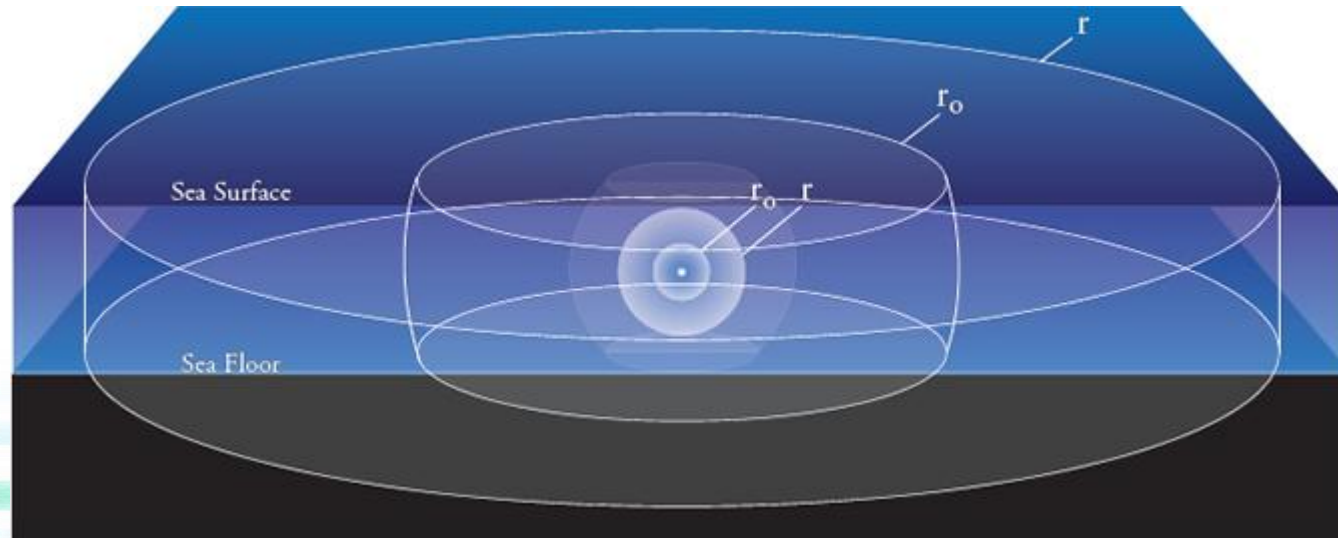

As acoustic waves propagate through the water, **they lose intensity** because of **geometric spreading** and **absorption**.

The result is an **across-track change in signal brightness** in the **waterfall display**.

Sidescan Gain and Signal Processing

SonarWiz provides algorithms for **leveling the brightness across track**.

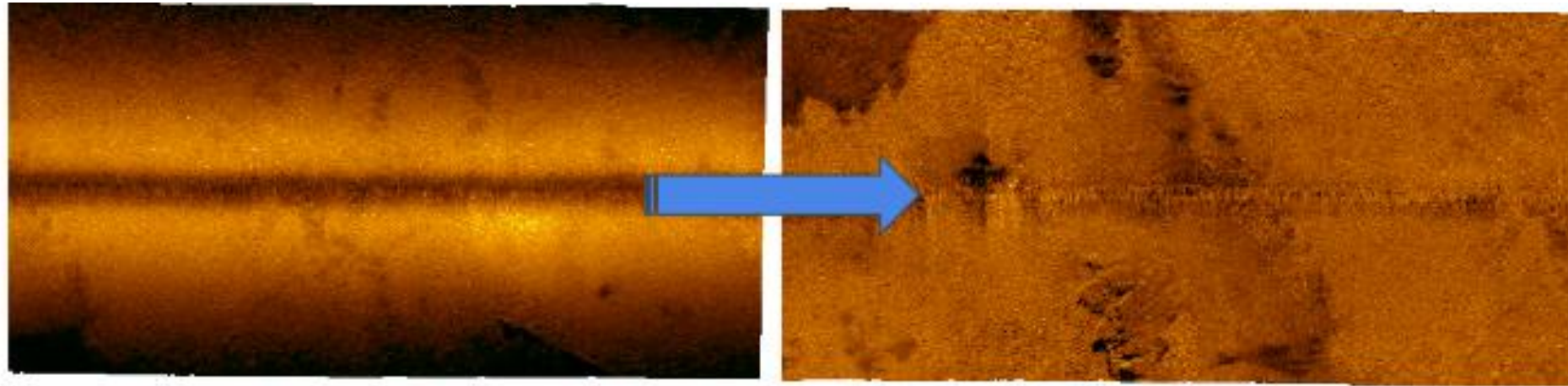

Automatic Gain Control

Auto TVG

Beam Angle Correction

Empirical Gain Normalization

Automatic Gain Control

The AGC Algorithm:

1. **measures a local average signal strength**, and then
2. **rescales all the data** so that the local average is shifted to some **chosen global average** that determines on the large-scale how quiet or loud the data will be after rescaling.

More specifically, the local average at a given ordinate is computed by averaging some number of samples to the left and right of this ordinate.

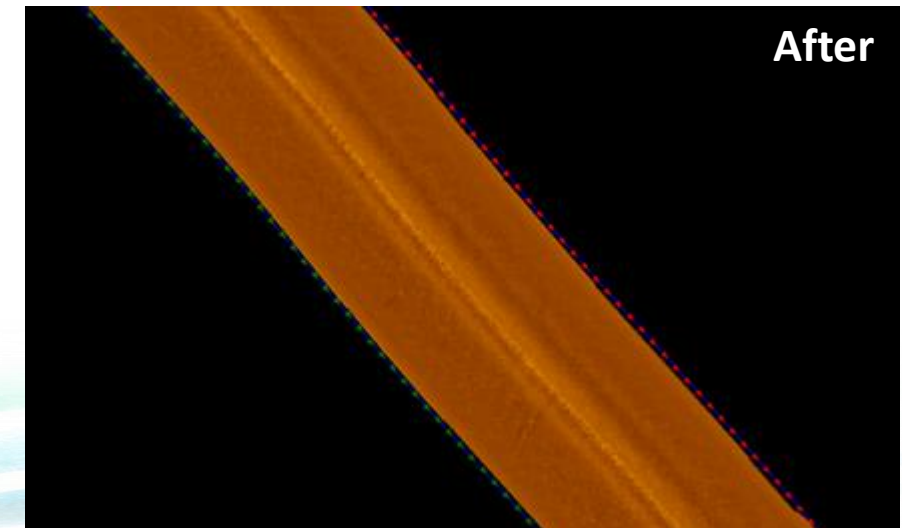
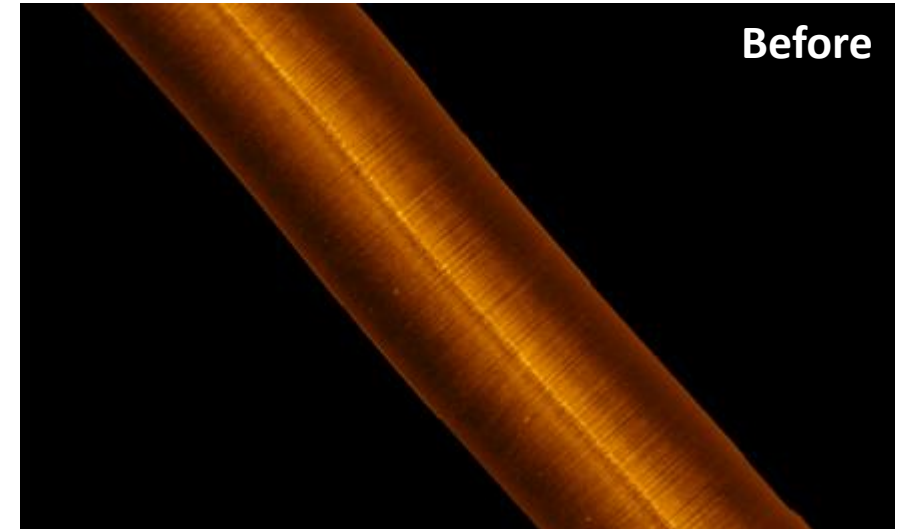

Beam Angle Correction

The Beam Angle Correction function (BAC):

attempts to compensate for non-linear response characteristics of the sonar transducers.

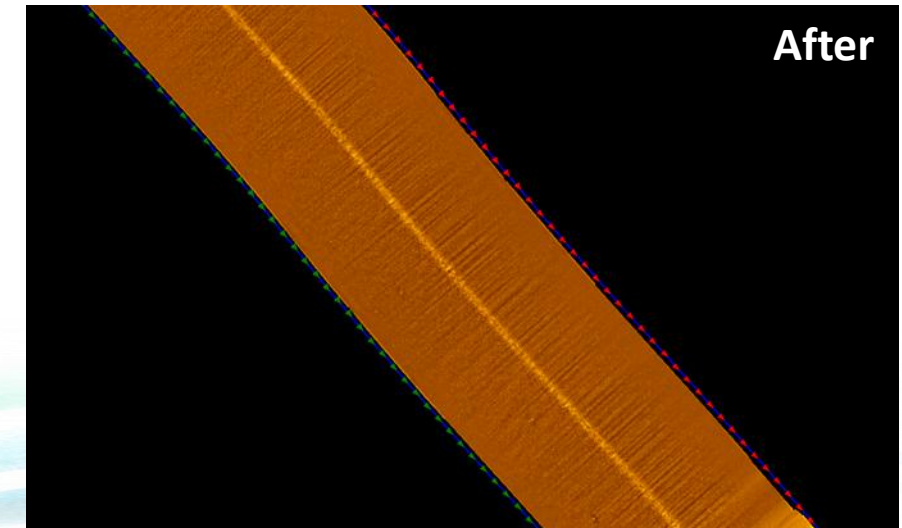
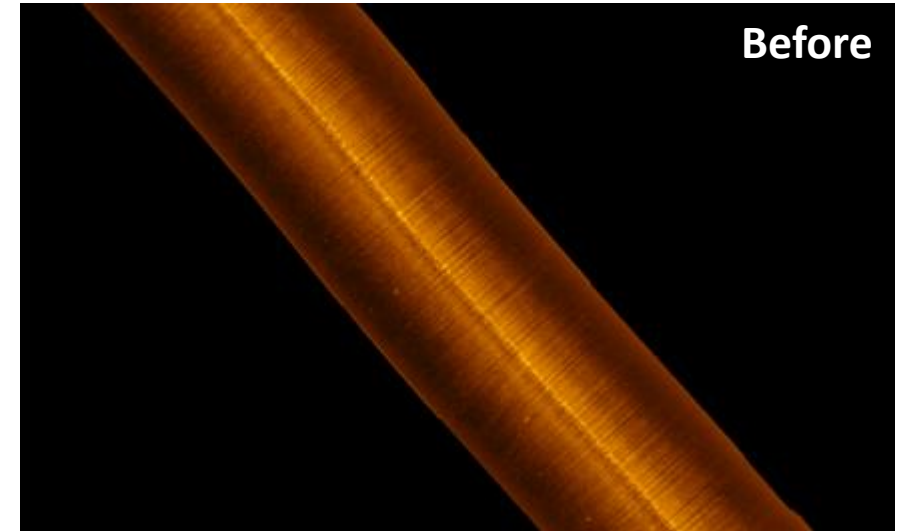

Auto TVG (Time Varying Gain)

The Auto TVG function:

1. **dividing** the data into many **parallel swaths**,
2. attempting to **equalize the backscatter** of each swath.
3. The **Root Mean Square** (RMS) power of each **swath is compared** to a desired power level.
4. **The error signal is fed back to an infinite impulse response (IIR) filter** and
5. the **gain for that swath** is adjusted in the **opposite direction**.

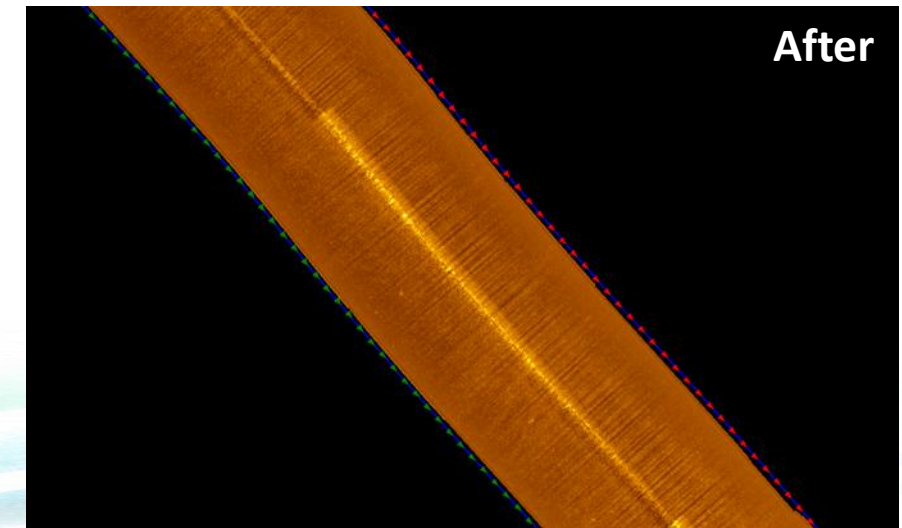
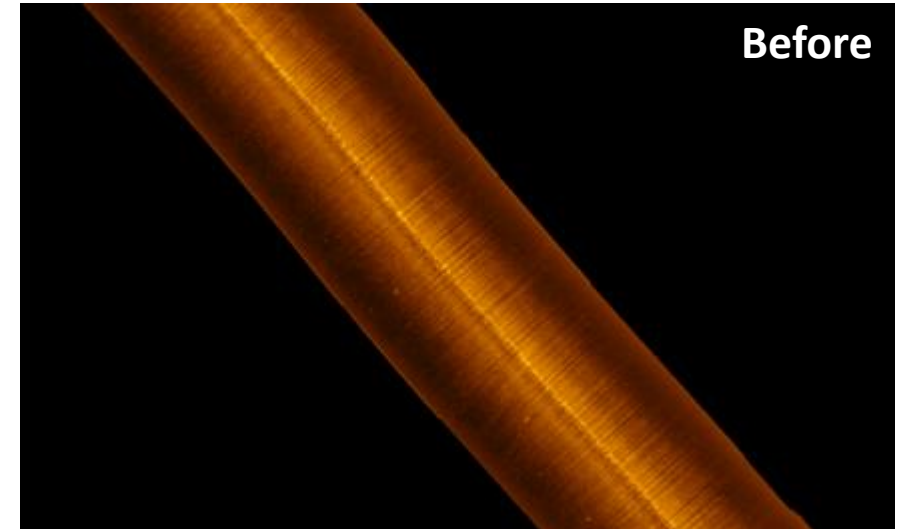

Empirical Gain Normalization

works extremely well in most situations and can be considered a replacement for BAC.

The Empirical Gain Normalization (EGN) function:

1. **sums and averages up all** of the **sonar amplitudes** in all pings in a set of sonar files **by altitude and range**.
2. **The amplitude values are summed and averaged by transducer** (port and starboard) so there are actually two tables.
3. The resulting table is used to work out the beam pattern of a sonar by **empirically looking at millions of samples of data**.

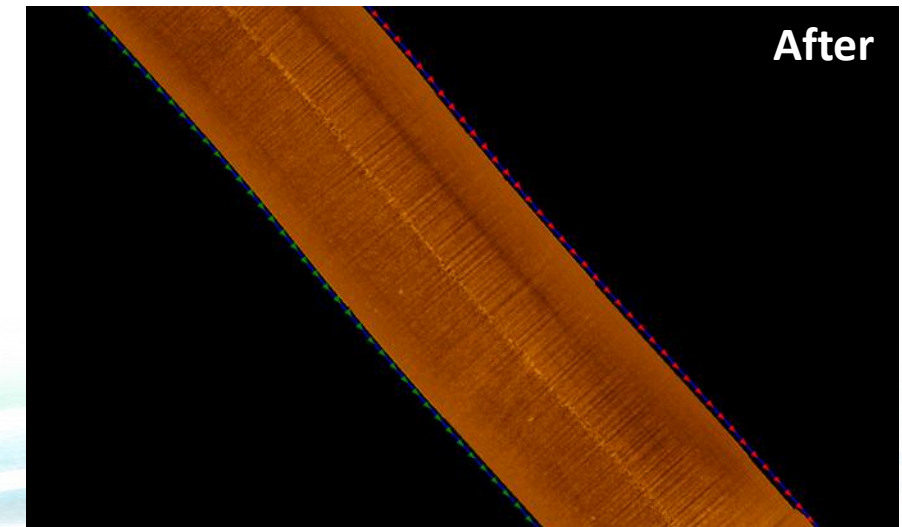
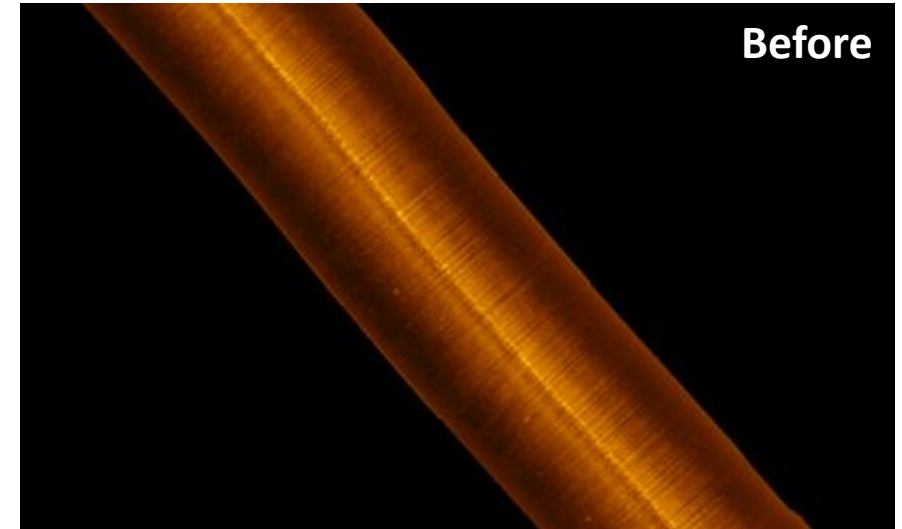

Sidescan Gain and Signal Processing

file
manager

System Information

Version: SonarWiz 5 V5.03.0009
License: SN:21845 UID:12336 R/T
User: Bandura Vladimir
State: Idle
Project: Efxinnos
Geodesy: UTM84-30N

System Time: 06/18/25 13:29:11
SSS Ping Number:
Ship Latitude:
Ship Longitude:
Ship Northing:
Ship Easting:
Ship Speed: 0.00
Ship Heading: 0.00
Ship Course: 0.00
Water Depth (m): 0.00

Sonar File Manager

Project: C:\Users\nikol\Desktop\Efxinnos\RTSYS\Presentation\Sonarwiz\Efxinnos.mml

Number of Files in Project: 3 Number of Files Enabled: 3

Limits of All Files			Limits of Enabled Files				
	Minimum:	Maximum:	Range:		Minimum:	Maximum:	Range:
X:	465020	465684	664	X:	465020	465684	664
Y:	5279039	5279439	400	Y:	5279039	5279439	400

<input checked="" type="checkbox"/>	Enable	File Name	Size	<input type="checkbox"/>	AGC	<input type="checkbox"/>	UGC
<input checked="" type="checkbox"/>	<input checked="" type="checkbox"/>	C:\Users\nikol\Desktop\Efxinnos\RTSYS\Presentation\Sonarwiz\CSF\20240326_141134_RTSYS_002.CSF	23280 KB	<input checked="" type="checkbox"/>	<input checked="" type="checkbox"/>	<input type="checkbox"/>	<input type="checkbox"/>
<input checked="" type="checkbox"/>	<input checked="" type="checkbox"/>	C:\Users\nikol\Desktop\Efxinnos\RTSYS\Presentation\Sonarwiz\CSF\20240326_142330_RTSYS_003.CSF	2301 KB	<input type="checkbox"/>	<input type="checkbox"/>	<input type="checkbox"/>	<input type="checkbox"/>
<input checked="" type="checkbox"/>	<input checked="" type="checkbox"/>	C:\Users\nikol\Desktop\Efxinnos\RTSYS\Presentation\Sonarwiz\CSF\20240326_135937_RTSYS_001.CSF	23280 KB	<input type="checkbox"/>	<input type="checkbox"/>	<input type="checkbox"/>	<input type="checkbox"/>

Buttons: OK, Cancel, Sheave Offset..., Batch Image Export..., Batch Bottom Track..., Make Like Selected..., Add File(s)..., Delete File(s)_, Rescan Limits, Select All, Aggregate, Bottom Track..., Digitizer View, Navigation..., Properties..., **Settings...**, Report..., Coverage..., Set Cable Out..., Offset Cable Out..., Set Sensor Depth..., Import Bottom Track

Sidescan Gain and Signal Processing

Settings for: 20240326_135937_RTSYS_001.CSF

- Enable BAC Pings: 30 Average: 20
- Enable AGC Resolution: 98 Intensity: 20
- Enable Auto TVG Port: 0 Stbd: 0
- Enable EGN Intensity: 80
- Enable User Defined Gain/Attenuation

Project Sonar Data Using...
 Course Made Good Rotate Port: 0.0 Rotate: 0.0
 Sensor Heading

Apply De-stripping

Sync Port/Stbd Gains

Rebuild Empirical Gain Normalization Table...

TVG Curve (Port) TVG Curve (Stbd)

Port TVG Curve: $20.0 * \log(R) + 0.00 * R + -10.0$

Stbd TVG Curve: $20.0 * \log(R) + 0.00 * R + -10.0$

Apply TVG Starting at...
 Time Zero Detected Sea Floor

System Information:
Version: SonarWiz 5 V5.03.0009
License: SN:21845 UID:12336 R/T
User: Bandura Vladimir
State: Idle
Project: Efxinnos
Geodesy: UTM84-30N

System Time: 06/18/25 13:29:11
SSS Ping Number:
Ship Latitude:
Ship Longitude:
Ship Northing:
Ship Easting:
Ship Speed: 0.00
Ship Heading: 0.00
Ship Course: 0.00
Water Depth (m): 0.00

De-Striping

The De-Striping function:

Is used to reduce the effects of a **'pitching'** sonar that is characterized by a pattern perpendicular to the direction of travel.

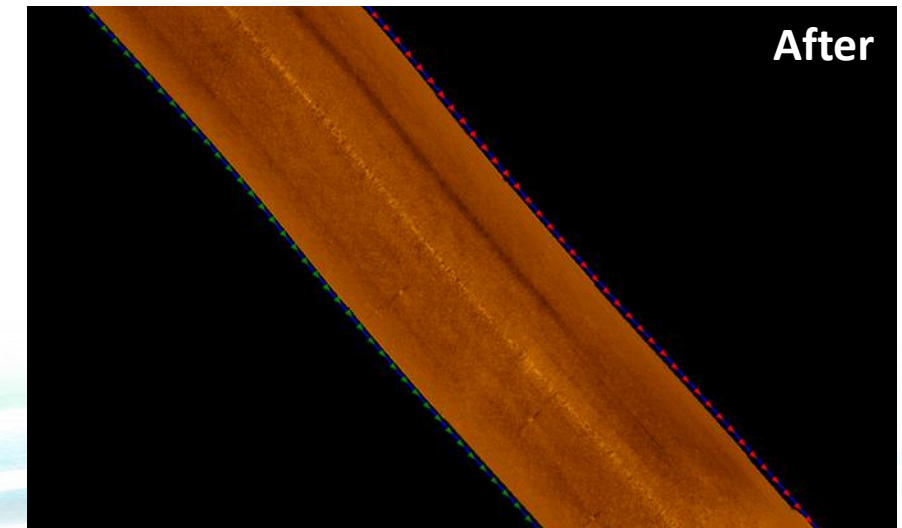
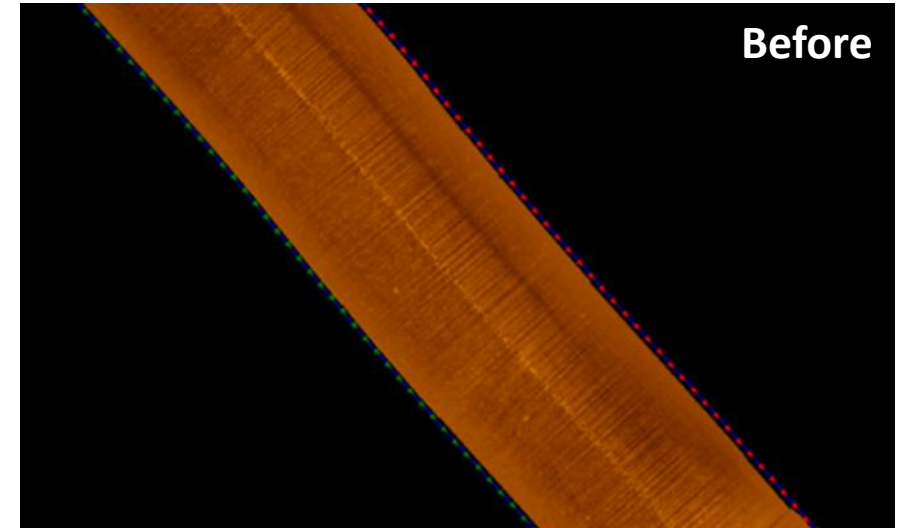
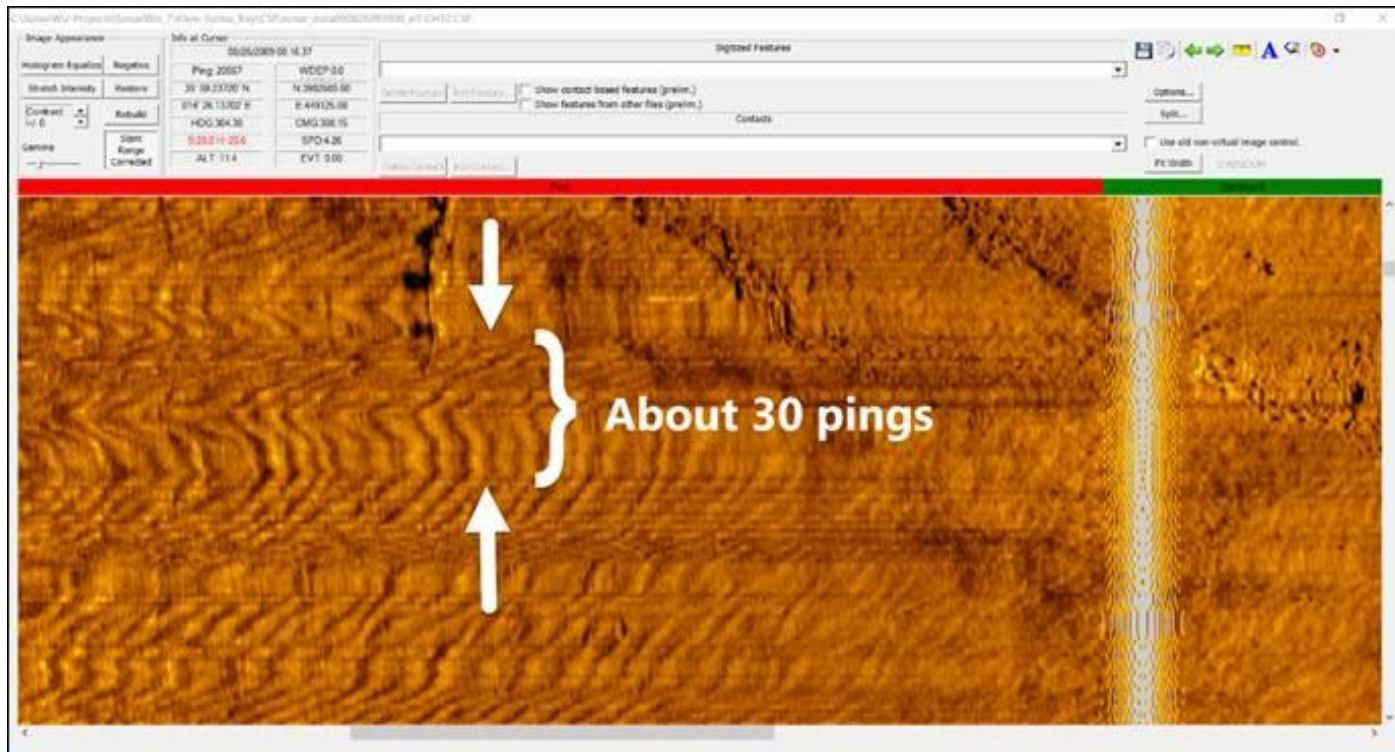

Export track

Save As Image File

Output Image File Name: C:\Users\nikol\Desktop\Efxinnos\RTSYS\Presentation\Sonarwiz\G...

Output Image File Type: GeoTIFF

Output Color Resolution: 32-bit

Specify Image Resolution: 0.500 Meters/pixel

Background Color: Black White

Crop the output image to selected Feature: Do Not Crop

Specify Image Size in Pixel

GeoTiff Pixel Dimensions

- Make Same Size as Current View
- Size to Fit Printer: Adobe PDF W:9917 H:14031
- Specify Size
 - Width: 1519
 - Height: 732

Launch Viewer after Saving

No Image Smoothing

OK Cancel

System Information

Version: SonarWiz 5 V5.
License: SN:21845 UID:
User: Bandura Vladimir
State: Idle
Project: Efxinnos
Geodesy: UTM84-30N

System Time: 06/18/25 18:31:11
SSS Ping Number:
Ship Latitude:
Ship Longitude:
Ship Northing:
Ship Easting:
Ship Speed: 0.00
Ship Heading: 0.00
Ship Course: 0.00
Water Depth (m): 0.00

CTI Support Redraw

47° 40.0411' N 003° 27.9685' W X:465004.9 Y:5279434.2 Z:0.0

Export track

The screenshot displays the QGIS desktop environment. The main map area shows a satellite view of a coastal region with a dark, elongated feature highlighted in black. The 'Layers' panel on the left lists 'Efxinnos' (with sub-layers for Red, Green, and Blue bands) and 'Google Satellite'. The 'Processing Toolbox' on the right shows the 'r.null' tool selected under the 'GRASS' > 'Raster (r.*)' category. A notification banner at the bottom of the toolbox reads: "You can add more algorithms to the toolbox, enable additional providers. [close]". The Windows taskbar at the bottom shows the system tray with a temperature of 30°C, the time 10:54 πμ, and the date 19/6/2025.

Export track

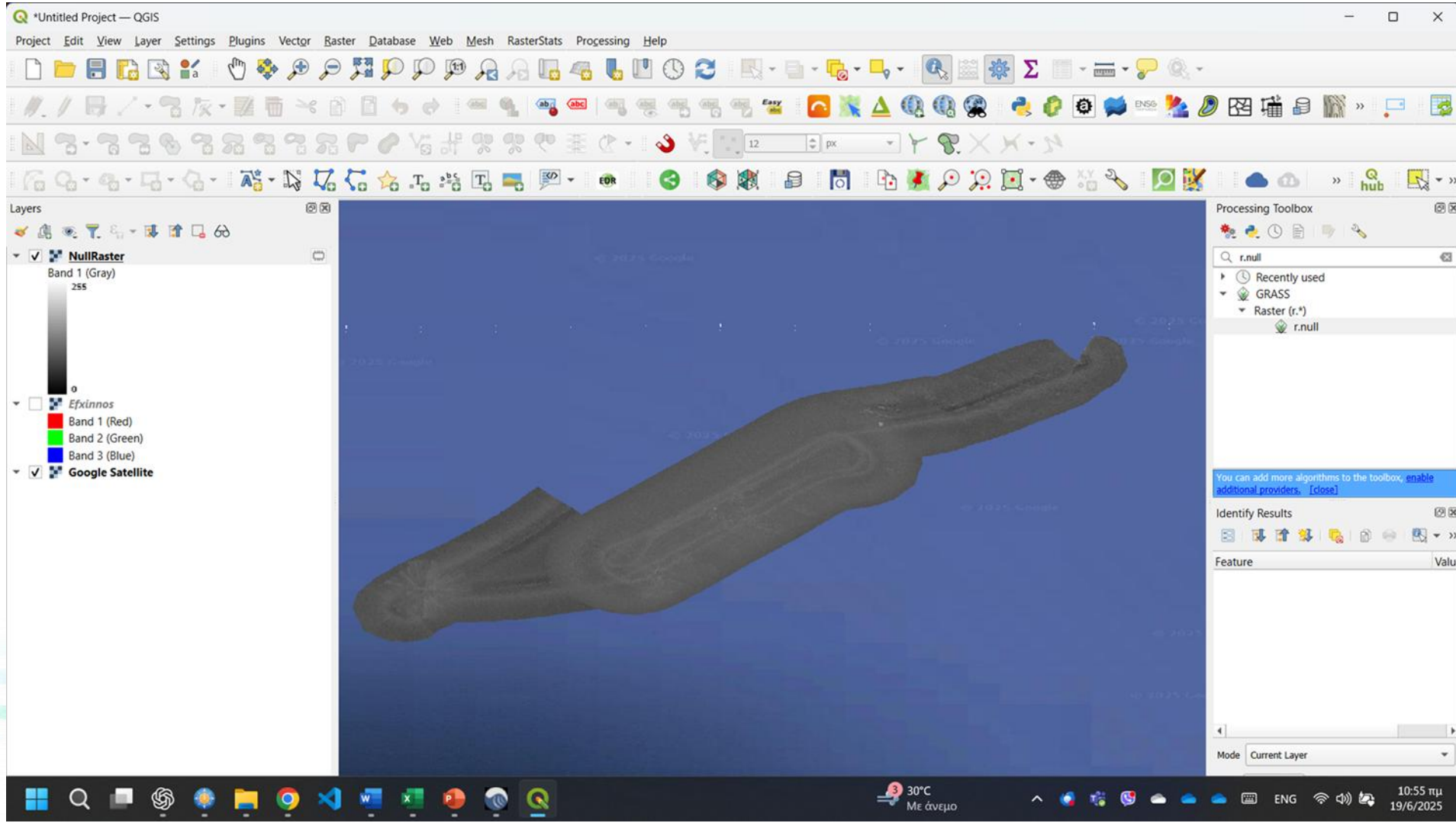

Digitizing features

digitizing
view

System Information

Version: SonarWiz 5 V5.03.0009
License: SN:21845 UID:12336 R/T
User: Bandura Vladimir
State: Idle
Project: Efxinnos
Geodesy: UTM84-30N

System Time: 06/18/25 18:21:33
SSS Ping Number:
Ship Latitude:
Ship Longitude:
Ship Northing:
Ship Easting:
Ship Speed: 0.00
Ship Heading: 0.00
Ship Course: 0.00
Water Depth (m): 0.00

Info at Cursor	
03/26/2024 14:01:53	
Ping: 2064	WDEP: 0.0
47° 39.97901' N	N: 5279316.23
003° 27.59036' W	E: 465477.47
HDG: 260.84	CMG: 256.44
SL: 10.9 H: 3.1	SPD: 0.00
ALT: 10.5	EVT: 2064.0

Image Appearance

Histogram Equalize: Negative:
Stretch Intensity: Restore:
Contrast: +/- 0
Gamma:
Rebuild: Slant Range Corrected:

Digitized Features

Delete Feature Edit Feature... Options... Split...

Targets

Delete Target Edit Target...

Port Starboard

Feature0001

CTI Support Redraw 47° 39.8620' N 003° 27.5335' W X:465547.3 Y:5279099.2 Z:0.0

Digitizing features

Feature manager

The screenshot displays the SonarWiz software interface. The main window has a menu bar (Data Acquisition, Post Processing, Maps, View, Tools, Help) and a toolbar with various icons. A red arrow points to the 'Feature Manager' icon in the toolbar. Below the main window, two dialog boxes are open: 'Feature Manager' and 'Feature Export'. The 'Feature Manager' dialog shows a table of features:

Dis...	Lab...	ID	Name
<input checked="" type="checkbox"/>	<input checked="" type="checkbox"/>	101847671	Feature0000
<input checked="" type="checkbox"/>	<input checked="" type="checkbox"/>	101973781	Feature0001

The 'Feature Export' dialog is open over the 'Feature Manager' dialog. It has a 'Destination Folder' field set to 'C:\Users\nikol\Desktop\Efxinnos\RTSYS\Presentation'. The 'Export Format' section has 'ESRI Shapefiles' selected. A red arrow points to the 'Export...' button in the 'Feature Export' dialog.

Digitizing features

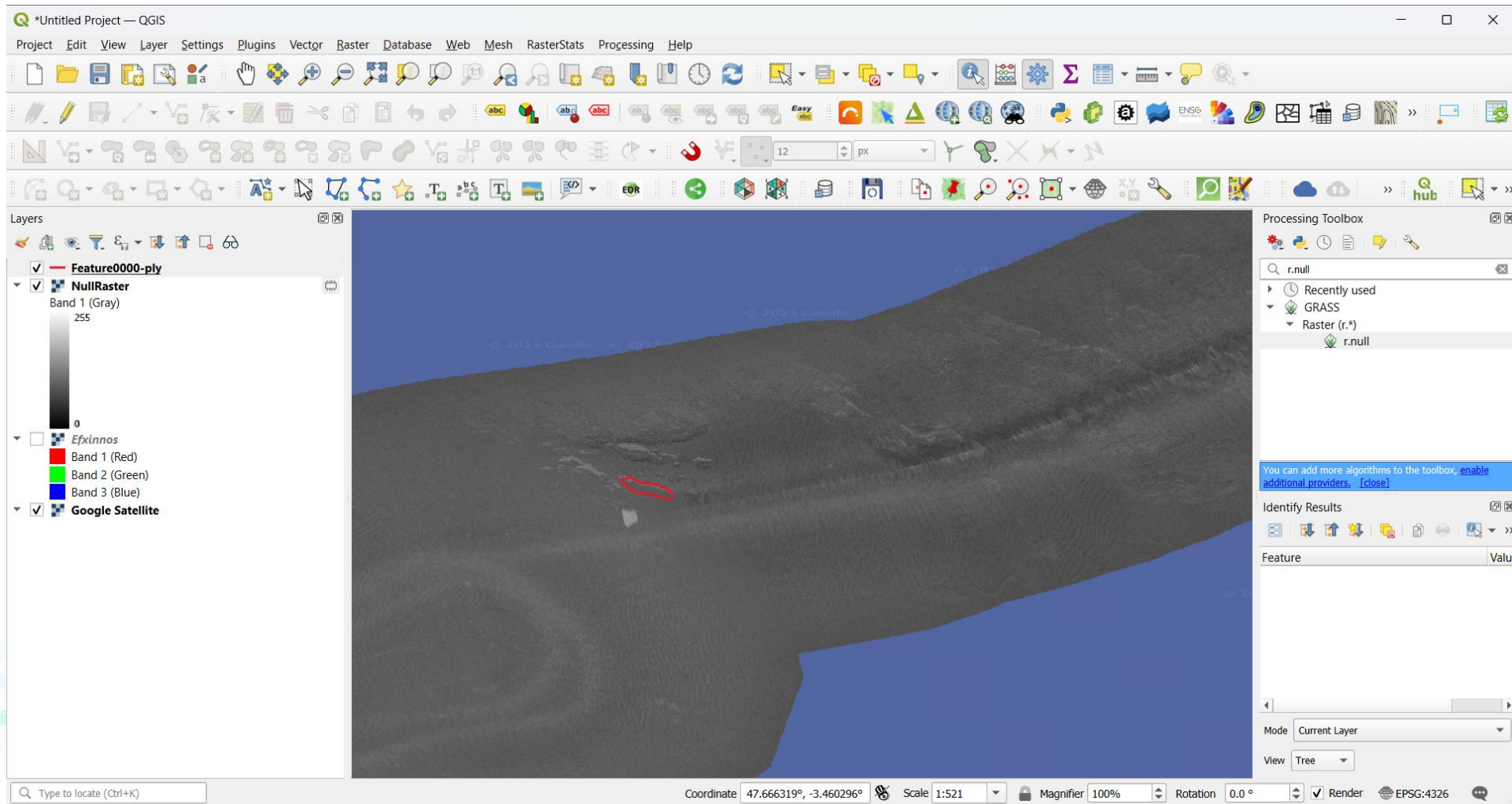

Capturing Contacts

Capture
contacts

The screenshot shows the SonarWiz software interface. The main window displays a sonar image with a red arrow pointing to the 'Capture Contact' icon in the toolbar. The 'Info at Cursor' window is open, showing the following data:

Info at Cursor	
03/26/2024 14:03:35	
Ping: 3602	WDEP: 0.0
47° 39.94813' N	N: 5279259.84
003° 27.70005' W	E: 465339.87
HDG: 238.73	
S: 21.4 H: 18.7	SPD: 0.00
ALT: 10.5	EVT: 3602.0

The 'Targets' window shows a list of targets, including 'Contact004'. The 'Port' and 'Starboard' windows are also visible, showing the sonar image split into two halves.

Capturing Contacts

Contacts manager

System Information

Version: SonarWiz 5 V5.03.0009
License: SN:21845 UID:12336 R/T
User: Bandura Vladimir
State: Idle
Project: Efxinnos
Geodesy: UTM84-30N

System Time: 06/18/25 18:21:33
SSS Ping Number:
Ship Latitude:
Ship Longitude:
Ship Northing:
Ship Easting:
Ship Speed: 0.00
Ship Heading: 0.00
Ship Course: 0.00
Water Depth (m): 0.00

Contact Manager

Number of Contacts in Project: 4 Number of Contacts Enabled: 4

<input checked="" type="checkbox"/>	<input type="checkbox"/>	<input checked="" type="checkbox"/>	<input checked="" type="checkbox"/>	Name	Latitude	Longitude	X	Y	
<input checked="" type="checkbox"/>	<input type="checkbox"/>	<input checked="" type="checkbox"/>	<input checked="" type="checkbox"/>	Contact0004	47° 39.98668' N	003° 27.59000' W	465478.00	5279330.43	C:\Users\nikol
<input checked="" type="checkbox"/>	<input type="checkbox"/>	<input checked="" type="checkbox"/>	<input checked="" type="checkbox"/>	Contact0005	47° 39.98399' N	003° 27.60449' W	465459.84	5279325.56	C:\Users\nikol
<input checked="" type="checkbox"/>	<input type="checkbox"/>	<input checked="" type="checkbox"/>	<input checked="" type="checkbox"/>	Contact0006	47° 39.95099' N	003° 27.65303' W	465398.75	5279264.79	C:\Users\nikol
<input checked="" type="checkbox"/>	<input type="checkbox"/>	<input checked="" type="checkbox"/>	<input checked="" type="checkbox"/>	Contact0007	47° 39.92562' N	003° 27.69058' W	465351.48	5279218.08	C:\Users\nikol

Filter: Build Apply Save

Current: deletedYN=0 Remove Retrieve

Deleted Contacts
 Show Deleted Contacts UnDelete Delete Contact(s)

OK
Edit Contact(s)
Select All
Report Generator...
Export...
S-57 Export...
Export to GeoTiff
Import...
Sort Contacts...
Backup Contacts
Recompute All
Recompute
Preferences...

CTI Support Redraw 47° 39.8620' N 003° 27.5335' W X:465547.3 Y:5279099.2 Z:0.0

Capturing Contacts

Report test

Generated on: 07/01/2025 05:18:32 PM by SonarWiz.MAP targetReportGen2 V3.13.01

Target Image	Target Info	User Entered Info
	<p>Contact0004</p> <ul style="list-style-type: none"> * Sonar Time at Target: 03/26/2024 14:01:51 * Click Position (Lat/Lon Coordinates) 47.6664466858 -3.4598329067 (WGS84) * Map Proj: * Acoustic Source File: C:\Users\niko1\Desktop\Efxinnos\RTSYS\Presentation\Input Data\20240326_135937_RTSYS_001.xtf * Ping Number: 2037 * Range to Target: 19.77 Meters * Fish Height: 10.47 Meters * Event Number: 2036 * Line Name: 20240326_135937_RTSYS_001 	<p>Dimensions and Attributes</p> <ul style="list-style-type: none"> * Target Height >= 0 Meters * Target Length: 0 Meters * Target Shadow: 0 Meters * Target Width: 0 Meters * Mag Anomaly: * Avoidance Area: * Classification 1: * Classification 2: * Area: * Block: * Description:
	<p>Contact0005</p> <ul style="list-style-type: none"> * Sonar Time at Target: 03/26/2024 14:02:05 * Click Position (Lat/Lon Coordinates) 47.6664009094 -3.4600749016 (WGS84) * Map Proj: * Acoustic Source File: C:\Users\niko1\Desktop\Efxinnos\RTSYS\Presentation\Input Data\20240326_135937_RTSYS_001.xtf * Ping Number: 2238 * Range to Target: 19.08 Meters * Fish Height: 10.57 Meters * Event Number: 2237 * Line Name: 20240326_135937_RTSYS_001 	<p>Dimensions and Attributes</p> <ul style="list-style-type: none"> * Target Height >= 0 Meters * Target Length: 0 Meters * Target Shadow: 0 Meters * Target Width: 0 Meters * Mag Anomaly: * Avoidance Area: * Classification 1: * Classification 2: * Area: * Block: * Description:



Developed by **ReefMaster Software**, is a Windows-based software.

<https://reefmaster.com.au/>

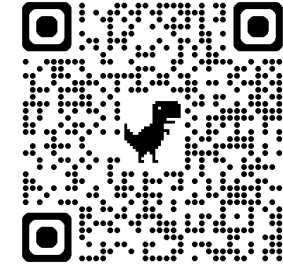

Underwater Mapping



- Create 2D/3D contour maps from sonar logs with real-time NMEA 0183 support.
- Fully customizable intervals and export in various formats.

Sidescan Mosaic



- Supports Lowrance & Humminbird sidescan data to create high-res mosaics from multiple logs.
- Easily review and export imagery in formats like KML and AT5.

Waypoint Management



- Edit waypoints in 2D/3D with drag-and-drop and attach notes/images.
- Import/export in formats



Multi-channel Sonar Viewer

- Advanced sonar viewer for Lowrance/Humminbird with split-screen, fast playback, and waypoint marking.
- Adjust visuals, measure distances, and estimate object height with ease.



Flexible Data Import/Export

- Combine data from sonar logs, GPX, NMEA 0183, Shapefiles, and more to create detailed maps.
- Export in formats like AT5, Google Earth, Shapefile, MBTiles, and high-res images.



Main View

The screenshot displays the ReefMaster software interface. At the top, there is a menu bar with 'FILE', 'VIEW', 'EDIT', 'WAYPOINTS', and 'LIVE DATA'. Below the menu is a toolbar with various icons for navigation and editing, including 'Select', 'Zoom', 'Pan', 'Region Select', 'Drop Waypoint', 'Measure Distance', 'Fit Window', 'Zoom In', 'Zoom Out', 'Grid Lines', 'Show Map', 'Background Images', and 'Show Mouse Tracer'. On the left side, there is a 'Workspace' panel with a tree view containing 'Map Projects', 'Sidescan Mosaics', 'Tracks', 'Waypoints', and 'Images'. The main area shows a map of the Black Sea region with a grid overlay. A dialog box titled 'Open Existing or Create New Workspace' is open in the center, displaying a list of 'Recent Workspaces' with their file paths. The dialog includes buttons for 'Check for Updates', 'New', and 'Browse...'. At the bottom of the interface, there is a status bar showing 'MOUSE: N057.21.953 W141.15.359' and 'Mouse Tracer: OFF DATA: OFF' with red 'P' and 'D' buttons.

ReefMaster - Reefmaster

FILE VIEW EDIT WAYPOINTS LIVE DATA

Select Zoom Pan Region Select Drop Waypoint Measure Distance Fit Window Zoom In Zoom Out Grid Lines Show Map Background Images Show Mouse Tracer

Mouse Mode Zoom Background

Workspace

- Map Projects
- Sidescan Mosaics
- Tracks
- Waypoints
- Images

Global View

Open Existing or Create New Workspace

Recent Workspaces

- Reefmaster**
C:\Users\niko\Desktop\Efxinnos\RTSYS\Presentation\Reefmaster\Reefmaster\Reefmaster.rm2db
- test**
C:\Users\niko\Desktop\test xtf\test\test.rm2db
- Perama**
C:\Users\niko\Desktop\Sonar\Reefmaster\Perama\Perama.rm2db
- Palio**
C:\Users\niko\Desktop\pyxtf\Data\Palio\Palio\Palio.rm2db

Check for Updates New Browse...

MOUSE: N057.21.953 W141.15.359 Mouse Tracer: OFF DATA: OFF P D

Import Data

The screenshot shows the ReefMaster software interface with the 'Import Logs and Waypoints' window open. The window title is 'ReefMaster - Reefmaster'. On the left is a dark blue sidebar with navigation options: 'Open Workspace', 'Import Logs and Waypoints', 'New', 'Settings', 'About ReefMaster', 'Help', 'Check for Updates', and 'Exit ReefMaster'. The main window contains the following sections:

- Equipment Profile:** A dropdown menu set to 'My GPS-Sounder' with a 'Browse...' button to its right.
- Profile name:** A text field containing 'My GPS-Sounder'.
- Keel offset (transducer depth):** A text field set to '0 metres'.
- GPX and Humminbird HT file import options:**
 - Regular Trackpoint Interval:** A text field set to '5' with the unit 'seconds'.
- Lowrance options:** A checkbox labeled 'Swap Latitude and Longitude' which is currently unchecked.
- Humminbird options:**
 - Water:** A dropdown menu set to 'Fresh'.
 - Temperature:** A text field set to '15 °C'.
 - Unicode Humminbird waypoint and track names**
- Transducer location relative to GPS antenna:**
 - Aft:** A dropdown menu and a text field set to '0 metres'.
 - Port:** A dropdown menu and a text field set to '0 metres'.
- Bottom composition import options:**
 - Scale:** A slider set to '1.0'.
 - Offset:** A slider set to '0'.
- Timezone:** A dropdown menu set to '(UTC+02:00) Athens, Bucharest'.
- Exclude zero depths**
- Apply tide adjustment** with a 'Tide station' dropdown menu.
- Do not import duplicate waypoints**



Add track to map

The screenshot shows the ReefMaster software interface. The main window is titled "ReefMaster - Reefmaster". The menu bar includes FILE, VIEW, EDIT, WAYPOINTS, and LIVE DATA. The toolbar contains various tools: Select, Zoom, Pan, Region Select, Drop Waypoint, Measure Distance, Fit Window, Zoom In, Zoom Out, Grid Lines, Show Map, Background Images, and Show Mouse Tracer. The workspace on the left is divided into several panes: Map Projects, Sidescan Mosaics, Tracks, Waypoints, and Images. The Tracks pane is expanded, showing a table with columns for Name and Time. A right-click context menu is open over the map, with the text "Right click" overlaid in red. The menu options are: Edit (Ctrl+E), Export (Ctrl+S), Delete (Del), Show in Global View, Add Track to Map Project, Add Track to Map Project as Layer, Add Track to Mosaic, New Project..., RTSYS, and RTSYS Track. The status bar at the bottom displays the current track name "Splitted\20240326_135937_RTYS_001", mouse coordinates "MOUSE: N047.39.351 W003.28.803", a distance of "1.51m", and status for "Mouse Tracer" (OFF) and "DATA" (OFF).

Name	Time
20240326_135937_R...	2025-03-2...
20240326_141134_R...	2025-03-2...
20240326_142330_R...	2025-03-2...



Map

The screenshot displays the ReefMaster software interface. The top menu bar includes FILE, VIEW, EDIT, WAYPOINTS, LIVE DATA, and PROJECT. The PROJECT menu is active, showing options for Export, Generate Map, Define Map Area, Generate Survey Lines, Tracks and Boundaries, Map View, and 3D View. The 'Generate Minor Contours' and 'Generate Isobaths' options are checked. The 'Map Settings' section includes 'Smoothing' (6), 'Max Interpolation (m)' (50), and 'Water Level Offset (m)' (0). The 'Map Project Views' section shows 'Major' (3) and 'Minor' (0.75 m) contour settings. The main map area shows a grid with coordinates (W003.27.800, W003.27.700, W003.27.600, W003.27.500) and (N047.40.000, N047.39.900). A track is visible, colored from blue to red, indicating depth or distance. The status bar at the bottom shows 'RTSYS', 'MOUSE: N047.39.966 W003.27.677 1.02m', and 'Mouse Tracer: OFF DATA: OFF'.

Name	Time
Splitted	
20240326_135937_R...	2025-03-24 19:45:43
20240326_141134_R...	2025-03-20 12:55:27
20240326_142330_R...	2025-03-20 12:54:17



Export track lines

The screenshot shows the ReefMaster software interface. The top menu bar includes FILE, VIEW, EDIT, WAYPOINTS, and LIVE DATA. Below the menu is a toolbar with icons for Select, Zoom, Pan, Region Select, Drop Waypoint, Measure Distance, Fit Window, Zoom In, Zoom Out, Grid Lines, Show Map, Background Images, and Show Mouse Tracer. The main workspace is titled 'Global View' and displays a map with a track line. A right-click context menu is open over the track line, showing options: Edit (Ctrl+E), Export (Ctrl+S), Delete (Del), Show in Global View, Add Track to Map Project, Add Track to Map Project as Layer, and Add Track to Mosaic. A 'New Project...' dialog box is also visible with the name 'Test'. The status bar at the bottom shows the current project name 'Splitted\20240326_135937_RT_SYS_001', mouse coordinates 'MOUSE: N047.39.351 W003.28.803', a distance of '1.51m', and status for 'Mouse Tracer' (OFF) and 'DATA' (OFF).

Name	Time
Splitted	
20240326_135937_R...	2025-03-26
20240326_141134_R...	2025-03-26
20240326_142330_R...	2025-03-26



Export track lines

Export track

The screenshot shows the ReefMaster software interface. The top menu bar includes FILE, VIEW, EDIT, WAYPOINTS, LIVE DATA, and PROJECT. The PROJECT menu is open, showing options: Export (highlighted with a red arrow), Generate Map, Define Map Area, Generate Survey Lines, Tracks and Boundaries, Map View, and 3D View. The 'Export' option is highlighted with a red arrow and the text 'Export track'.

The main workspace displays a map with a red track line. The track starts at the bottom left, loops around, and then extends towards the top right. The map has a grid with coordinates: W003.27.800, W003.27.700, W003.27.600, W003.27.500, W003.27.400, W003.27.300, W003.27.200, W003.27.100, W003.27.000, W003.26.900, W003.26.800, W003.26.700, W003.26.600, W003.26.500, W003.26.400, W003.26.300, W003.26.200, W003.26.100, W003.26.000, W003.25.900, W003.25.800, W003.25.700, W003.25.600, W003.25.500, W003.25.400, W003.25.300, W003.25.200, W003.25.100, W003.25.000, W003.24.900, W003.24.800, W003.24.700, W003.24.600, W003.24.500, W003.24.400, W003.24.300, W003.24.200, W003.24.100, W003.24.000, W003.23.900, W003.23.800, W003.23.700, W003.23.600, W003.23.500, W003.23.400, W003.23.300, W003.23.200, W003.23.100, W003.23.000, W003.22.900, W003.22.800, W003.22.700, W003.22.600, W003.22.500, W003.22.400, W003.22.300, W003.22.200, W003.22.100, W003.22.000, W003.21.900, W003.21.800, W003.21.700, W003.21.600, W003.21.500, W003.21.400, W003.21.300, W003.21.200, W003.21.100, W003.21.000, W003.20.900, W003.20.800, W003.20.700, W003.20.600, W003.20.500, W003.20.400, W003.20.300, W003.20.200, W003.20.100, W003.20.000, W003.19.900, W003.19.800, W003.19.700, W003.19.600, W003.19.500, W003.19.400, W003.19.300, W003.19.200, W003.19.100, W003.19.000, W003.18.900, W003.18.800, W003.18.700, W003.18.600, W003.18.500, W003.18.400, W003.18.300, W003.18.200, W003.18.100, W003.18.000, W003.17.900, W003.17.800, W003.17.700, W003.17.600, W003.17.500, W003.17.400, W003.17.300, W003.17.200, W003.17.100, W003.17.000, W003.16.900, W003.16.800, W003.16.700, W003.16.600, W003.16.500, W003.16.400, W003.16.300, W003.16.200, W003.16.100, W003.16.000, W003.15.900, W003.15.800, W003.15.700, W003.15.600, W003.15.500, W003.15.400, W003.15.300, W003.15.200, W003.15.100, W003.15.000, W003.14.900, W003.14.800, W003.14.700, W003.14.600, W003.14.500, W003.14.400, W003.14.300, W003.14.200, W003.14.100, W003.14.000, W003.13.900, W003.13.800, W003.13.700, W003.13.600, W003.13.500, W003.13.400, W003.13.300, W003.13.200, W003.13.100, W003.13.000, W003.12.900, W003.12.800, W003.12.700, W003.12.600, W003.12.500, W003.12.400, W003.12.300, W003.12.200, W003.12.100, W003.12.000, W003.11.900, W003.11.800, W003.11.700, W003.11.600, W003.11.500, W003.11.400, W003.11.300, W003.11.200, W003.11.100, W003.11.000, W003.10.900, W003.10.800, W003.10.700, W003.10.600, W003.10.500, W003.10.400, W003.10.300, W003.10.200, W003.10.100, W003.10.000, W003.9.900, W003.9.800, W003.9.700, W003.9.600, W003.9.500, W003.9.400, W003.9.300, W003.9.200, W003.9.100, W003.9.000, W003.8.900, W003.8.800, W003.8.700, W003.8.600, W003.8.500, W003.8.400, W003.8.300, W003.8.200, W003.8.100, W003.8.000, W003.7.900, W003.7.800, W003.7.700, W003.7.600, W003.7.500, W003.7.400, W003.7.300, W003.7.200, W003.7.100, W003.7.000, W003.6.900, W003.6.800, W003.6.700, W003.6.600, W003.6.500, W003.6.400, W003.6.300, W003.6.200, W003.6.100, W003.6.000, W003.5.900, W003.5.800, W003.5.700, W003.5.600, W003.5.500, W003.5.400, W003.5.300, W003.5.200, W003.5.100, W003.5.000, W003.4.900, W003.4.800, W003.4.700, W003.4.600, W003.4.500, W003.4.400, W003.4.300, W003.4.200, W003.4.100, W003.4.000, W003.3.900, W003.3.800, W003.3.700, W003.3.600, W003.3.500, W003.3.400, W003.3.300, W003.3.200, W003.3.100, W003.3.000, W003.2.900, W003.2.800, W003.2.700, W003.2.600, W003.2.500, W003.2.400, W003.2.300, W003.2.200, W003.2.100, W003.2.000, W003.1.900, W003.1.800, W003.1.700, W003.1.600, W003.1.500, W003.1.400, W003.1.300, W003.1.200, W003.1.100, W003.1.000, W003.0.900, W003.0.800, W003.0.700, W003.0.600, W003.0.500, W003.0.400, W003.0.300, W003.0.200, W003.0.100, W003.0.000.

The status bar at the bottom shows: MOUSE: N047.39.952 W003.27.520 1.02m Mouse Tracer: OFF DATA: OFF P D

Generate survey lines

Export track

The screenshot shows the ReefMaster software interface. The 'PROJECT' menu is open, and the 'Export' button is highlighted with a red arrow. The interface includes a menu bar (FILE, VIEW, EDIT, WAYPOINTS, LIVE DATA, PROJECT), a toolbar with icons for 'Export', 'Generate Map', 'Define Map Area', 'Generate Survey Lines', 'Tracks and Boundaries', 'Map View', and '3D View'. The 'PROJECT' panel shows settings for 'Major' (3), 'Minor' (0.75 m), 'Generate Minor Contours' (checked), 'Generate Isobaths' (checked), 'Smoothing' (6), 'Max Interpolation (m)' (50), and 'Water Level Offset (m)' (0). The 'Workspace' panel shows a list of tracks, including 'RTSYS Track' and 'Splitted' tracks. The main map area displays a survey track (green line) overlaid on a grid of red diagonal lines. The status bar at the bottom shows coordinates: MOUSE: N047.39.979 W003.27.329 1.02m, and Mouse Tracer: OFF, DATA: OFF.



Create Mosaic

Show sidescan

The screenshot shows the ReefMaster software interface. The main window displays a map with a track and sidescan data. The track is highlighted in orange, and the sidescan data is shown as a blue and white line. A red arrow points to the 'Show Sidescan' button in the toolbar.

Toolbar: FILE, VIEW, EDIT, WAYPOINTS, LIVE DATA, TRACK. Buttons: Export Track, Track Palette, Show Bottom, PeakSV, Variable depth, Sonar Viewer, Correct Depths, Show Sidescan.

Workspace: Global View, 20240326_135937_RTYS_001 x

Map Projects: RTSYS, RTSYS Track

Sidescan Mosaics: (Empty)

Tracks:

Name	Time
Splitted	
20240326_135937_R...	2025-03-24 19:45:43
20240326_141134_R...	2025-03-20 12:55:27
20240326_142330_R...	2025-03-20 12:54:17

Waypoints: Default Set

Images: (Empty)

Status Bar: Splitted\20240326_135937_RTYS_001 | MOUSE: N047.39.928 W003.27.708 0.98m | Mouse Tracer: OFF | DATA: OFF | P D

Create Mosaic

uncheck "Use Headings"

The screenshot shows the ReefMaster software interface. The 'TRACK SIDESCAN' menu is open, and the 'Use Headings' checkbox is unchecked. A red arrow points to this checkbox. The main map area displays a sidescan mosaic of a seabed profile. The left sidebar shows the 'Workspace' with 'Sidescan Mosaics' selected. The status bar at the bottom shows coordinates and depth: N047.39.967, W003.27.581, 1.06m.

Name	Time
Splitted	
20240326_135937_R...	2025-03-24 19:45:43
20240326_141134_R...	2025-03-20 12:55:27
20240326_142330_R...	2025-03-20 12:54:17

Create Mosaic

The screenshot shows the ReefMaster software interface. The main window displays a sidescan mosaic of a seabed area, with a yellow and orange color scale representing depth or sediment type. A red arrow points to the mosaic, and a red text label "Right click" is positioned above a context menu that appears over the mosaic. The context menu includes options like "Add to Mosaic" and "New Mosaic..".

The interface includes a menu bar (FILE, VIEW, EDIT, WAYPOINTS, LIVE DATA, TRACK, TRACK SIDESCAN), a toolbar with various icons, and a workspace area with several panels:

- Map Projects:** Shows the current project name "20240326_135937_RTSYS_001".
- Sidescan Mosaics:** A list of mosaics.
- Tracks:** A table showing track details.
- Waypoints:** A list of waypoints.
- Images:** A list of images.

Name	Time
Splitted	
20240326_135937_R...	2025-03-24 19:45:43
20240326_141134_R...	2025-03-20 12:55:27
20240326_142330_R...	2025-03-20 12:54:17

The status bar at the bottom shows the current track name "Splitted\20240326_135937_RTSYS_001", mouse coordinates (MOUSE: N047.39.933 W003.27.467), depth (1.06m), and status indicators for Mouse Tracer and DATA.

Export Mosaic

Export mosaic

The screenshot shows the ReefMaster software interface with the 'Export Mosaic Image' dialog box open. The dialog box contains the following options:

- MBTiles**
- PNG Image**
- KML Super-overlay** (Selected): Export side-scan mosaic image as a KML Super-overlay for display in Google Earth. KML Super-overlays are composed of a large number of image tiles rendered in a range of resolutions, allowing very large images to be displayed. A KML Super-overlay export creates a single, top level KML file and an associated `_files` directory containing the image tiles.
- AT5 Raster Layer**

At the bottom of the dialog box, there is a slider for 'Pixels per metre' set to 10 5066x3684 px.

The background interface shows a workspace with 'Map Projects', 'Sidescan Mosaics', 'Tracks', 'Waypoints', and 'Images' panels. The main map area displays a side-scan mosaic of a seabed area. The status bar at the bottom shows coordinates: MOUSE: N047.39.991 W003.27.734 and Mouse Tracer: OFF DATA: OFF.

View Mosaic

Export Sidescan Mosaic

MBTiles	KML Super-overlay
PNG Image	Export side-scan mosaic image as a KML Super-overlay for display in Google Earth. KML Super-overlays are composed of a large number of image tiles rendered in a range of resolutions, allowing very large images to be displayed.
KML Super-overlay	A KML Super-overlay export creates a single, top level KML file and an associated <i>_files</i> directory containing the image tiles.
AT5 Raster Layer	

Pixels per metre: 10 5066x3684 px

Layers: RTSYS, Google Satellite

Processing Toolbox: Recently used, 3D Tiles, Cartography, Check geometry, Database, File tools, Fix geometry, GPS, Interpolation, Layer tools, Mesh, Metadata tools, Network analysis, Plots, Point cloud conversion, Point cloud data management, Point cloud extraction, Raster analysis, Raster creation, Raster terrain analysis, Raster tools, Vector analysis, Vector coverage, Vector creation, Vector general, Vector geometry

Coordinate: -385293, 6051554 | Scale: 1:4815 | Magnifier: 100% | Rotation: 0.0° | Render: EPSG:3857

Interreg



Co-funded by
the European Union



NEXT Black Sea Basin
NEXT Black Sea Basin

